



Headquarters / Engineering research laboratory :
23 Gunpo Advanced Industry 1-ro(Bugok-dong), Gunpo-si, Gyeonggi-do
Tel +82-31-490-0800 Fax +82-31-490-0801

Yeongnam business office / Plant :
55 Gonghangap-gil 85beon-gil, Gangseogu, Busan Metropolitan City
Tel +51-973-8518 Fax +51-973-8519

E-mail : info@gastron.com

www.gastron.com

GTC-542

Instruction Manual



Read in detail for correct use.

Gas & Flame Detection System

GASTRON



In case of a problem after purchasing the product,
please contact the address below.

- Address : 23 Gunpo Advanced Industry 1-ro,
Gunpo-si, Gyeonggi-do
- Tel : 031-490-0800
- Fax : 031-490-0801
- URL : www.gastron.com
- e-mail : info@gastron.com

Thank you very much for purchasing a product from GasTron Co. Ltd.

Our Gastron Co.Ltd. is a company specialized in Gas Detector & Gas Monitoring System and have been recognized by many customers for the best quality and use convenience. We always seek to help our customers to find the product they need and we continuously research to develop gas detectors that satisfies our customers. From now on, you can solve all problems related to gas detectors with the products of Gastron. We Gastron, will be responsible for your satisfaction.

This user manual describes operation and simple maintenance methods etc. for the gas detector. Please read carefully and store it in a safe place. Using it as a reference will help a lot when you have a question during use.

- For an accurate operation of the gas detector, please perform an inspection and a calibration at least once per 6 months.
(* In reference to KOSHA GUIDE: P-135/6-2018 / 7.2 In-house inspection, section 2)
- For an accurate operation of the gas detector, inspection and calibration using a reference gas before measurement is recommended.
- Failure to calibrate may result in malfunction of the equipment due to aging of the sensor.
- Only an individual specialized in gas detector may disassemble the device.
- Wire specification for the power cable must be decided in reference to the "Installation cable length" section.
- Please contact our company's technical support, e-mail, or website for inquiries related to inspection and calibration of the gas detector.

The product and manual are subject to change without a notice for the product's functional improvement and ease of use.

* KOSHA GUIDE : P-135/6-2018

Calibration must be performed at a frequency requested by the manufacturer and shall be performed quarterly when the calibration period is not specified.

1. Overview	6		
2. Characteristics	6		
3. Specifications	7		
3.1. Basic Specifications	7		
3.2. Mechanical Specifications	7		
3.3. Electrical Specifications (Standard Type)	8		
3.4. Environmental Specifications	8		
4. Name and Description of Each part	9		
5. Installation	12		
5.1. Power Configuration	12		
5.2. Signal Terminal Configuration	13		
5.3. Relay Terminal Configuration	14		
5.4. 3-wire Type Gas detector Connection Method	15		
5.5. 2-wire Type Gas detector Connection Method	15		
6. Operation Method	16		
6.1. Power ON	16		
6.2. Power Display	16		
6.3. Measuring Mode	17		
6.4. Test Mode	17		
6.5. Stand-by Mode	18		
6.6. Operation Status Setting	18		
6.6.1. Setting Table	18		
6.6.2. PROGRAM MODE	20		
6.6.3. ALARM Mode	23		
6.6.4. Option Mode (Option setting)	27		
6.6.5. Test Mode	30		
6.6.6. 485 Setting Mode	32		
		6.6.7. Maintenance Mode	33
		6.6.8. Factory Initialization mode	36
		6.6.9. Calibration Data Initialization Mode	37
		7. Interface Configuration	38
		7.1. MODBUS RS485	38
		7.1.1. Interface Setting	38
		7.1.2. MODBUS RS485 Register map	38
		8. Drawings and Dimensions	39
		8.1. Drawing 1	39
		8.2. Drawing 2	40
		9. Revision History	41

Receiver of GTC-542 is a receiver with high-performance A/D converter and micro-processor and has various functions built-in. The receiver of GTC-542 is a stand-alone type that is connected to one detector and is protected by a case made of ABS material. It displays the concentration using FND digital display and 3-color bar graphic LED. It has primary, secondary, and tertiary alarm functions and fault alarm function.

2. Characteristics

In an event of error, GTC-542 stand-alone receiver displays audible signal (buzzer) and visible signal (Alarm LED) and has a function to hold the maximum measured value.
GTC-542 receiver can be controlled remotely to release the alarm and can perform associated control functions since it has an output for an error (SPDT contact).
GTC-542 receiver provides 4-20mA. DC output for the measured value and is able to communicate digitally using RS-485 network signal (Option).

3.1. Basic Specifications

ITEMS	SPECIFICATION	
Measuring Value Display	1.8" 3-Digit FND (2Color)& Bar graph(32 segment/3Color)	
Measuring Range	Capable to display 00.0 ~ 999	
Alarm Indicator	Visible Indicator: 3-Alarm, Stand-by LED, Warning Light Audible Indicator: Buzzer Signal (85 dB)	
Alarm Output Signal	3-Level Alarm, Trouble Relay	
Reset Signal	RESET Switch and Remote Reset Control	
Input Signal	4~20 mA DC	
Output Signal	Isolated RS-485 Modbus (Option)	
Approvals Classification	CE	
Basic Interface	Analog 4-20mA current interface	
Option	MODBUS RS485 Board	
Warranty	Transmitter	2 Years
	Sensor	1 Year

3.2. Mechanical Specifications

ITEMS	SPECIFICATION
Dimension	235(W) × 355(H) × 117(D) mm
Weight including Sensor	App. 1.4kg
Mounting Type	Wall mount
Body Material	ABS

3.3. Electrical Specifications (Standard Type)

ITEMS	SPECIFICATION	
Input Voltage(AC Type/Standard)	Absolute min: Nominal: Absolute max:	AC 90V AC 220V AC 250V
Input Voltage(DC Type) ※ Customer supplied PSU must meet requirements IEC1010-1 and CE Marking requirements.	Absolute min: Nominal: Absolute max: Ripple maximum allowed:	18V 24V 31V 1V pk-pk
Wattage(DC Type)	Max. wattage: Max. current:	4.32W @+24 VDC 180mA @+24 VDC
Analog output Current	0-20mA(500 ohms max load) All readings ± 0.2mA Measured-value signal: 4mA(Zero) to 20mA(Full Scale)	
	Fault: 0-100% LEL: 100-109%LEL: Over 110% LEL: Maintenance:	0mA 4mA - 20mA 21.6mA 20mA - 21.4mA 3mA
Analog output current ripple & noise max		±20uA
Relay contact	Alarm1, Alarm2, Alarm3, Fault Relay AC250V 5A Relay contact(SPDT)	
Wiring requirement	Power	CVVS or CVVSB with shield
	Analog RS485	CVVS or CVVSB with shield STP(Shielded Twisted Pair)
Cable Connection Length	Analog	2500m
	RS485	1000m
EMC Protection:		

3.4. Environmental Specifications

ITEMS	SPECIFICATION
Operation Temperature	-20 to 60 °C
Storage Temperature	-20 to 60 °C
Operation Humidity	0~ 99% RH (Non-condensing)
Pressure Range	90 to 110 kPa

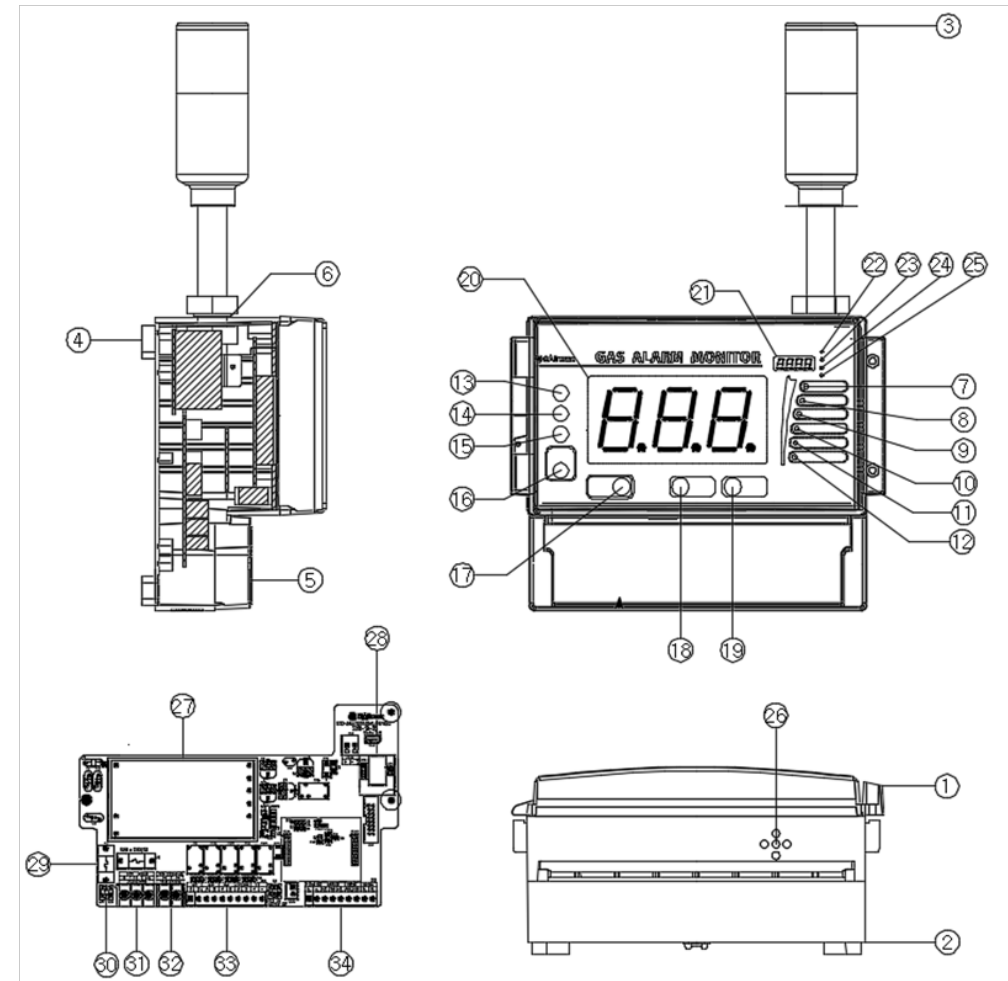

[Figure 1. GTC-542 Components]

4. Name and Description of Each Part

No	ITEMS	SPECIFICATION
1	Case cover	It is made of ABS Material. It fixes the display and protects the circuit from surrounding environment and external shock.
2	Case Body	It is made of ABS Material. It fixes the Main PCB and protects the circuit from surrounding environment and external shock.
3	Warning Light	Upon an event of error, the warning light turns on.
4	Mount hole(2-Ø6.5)	It is a hole to fix the control unit to an external wall or other mount plate.
5	Terminal Block Cover	Protective cover for terminal block that supplies power and signal to the product.
6	O-Ring < NBR >	Fixes the warning light.
7	Network LED	Flickers during RS-485 network.
8	Stand-by LED	When the detector is in stand-by mode, STD-BY LED blinks.
9	Fault LED	Upon an event of trouble in receiver unit and detector part, the trouble LED lights on.
10	Alarm 3 LED	When the tertiary alarm occurs, Alarm 3 LED lights on. When it reaches Alarm 3 threshold during a test, Alarm 3 LED lights on.
11	Alarm 2 LED	When the secondary alarm occurs, Alarm 2 LED lights on. When it reaches Alarm 2 threshold during a test, Alarm 2 LED lights on.
12	Alarm 1 LED	When the primary alarm occurs, Alarm 1 LED lights on. When it reaches Alarm 1 threshold during a test, Alarm 1 LED lights on.
13	FUNC key	"FUNC" KEY is a key to change to select and enter data for alarm threshold, alarm type, alarm dead band, and alarm dwell time settings, etc.
14	UP(▲) key	After selecting each mode using "FUNC" KEY, it is used to increase the set value or to select the next setting. When a value needs to be changes in a large range, pressing "▲" KEY for a certain time changes the value rapidly.
15	DOWN (▼(Test)) KEY (Stand-by)	After selecting each mode using "FUNC" KEY, it is used to decrease the set value or to select the previous setting. When a value needs to be changes in a large range, pressing " (▼(Test))KEY" for a certain time changes the value rapidly.
16	Return Key	Performs functions to release alarm, self-test, and program setting, etc.
17	Buzzer Stop Key	Used to stop the buzzer upon an event of an alarm
18	Test Key	Pressing "TEST" key enters a mode that performs self-test. Measurement FND flickers and the value can be adjusted using "TEST" key to check the alarm operation status. To release self-test, press "RESET" KEY.

4. Name and Description of Each Part

No	ITEMS	SPECIFICATION
19	Spare Power Test Key	Used for checking battery. Upon input, spare power voltage is displayed on Battery FND.
20	LCD PCB Assy	Used for displaying measurement from the detector or internal status of the device. During test, it displays user defined value with flickering.
21	Power FND	Used to display the power status and spare power status of the device currently being used.
22	Main Power LED	Displays external power status supplied to the device. Lights on when the external power is normal.
23	Spare power LED	Displays external spare power status supplied to the device. Lights on when the external spare power is normal.
24	Spare Power Normal LED	Lights on when it is normal during spare power test.
25	Spare Power Fault LED	Lights on when it is in fault status during spare power test.
26	Buzzer	Operates in a continuous tone upon an event of warning or fault during a test.
27	SMPS	Converter that converts 220V-AC to 24V-DC power. Removed when the option is DC power.
28	RS-485 module(Optional)	RS-485 network module is isolated type that connects PC and other external network devices to receive and transmit the current concentration and settings, etc.
29	Fuse	Works as a breaker to protect the equipment by cutting fuse with heat generated from overcurrent.
30	Power ON/OFF Switch	S/W used to turn ON and OFF of the control unit power. When performing cable wiring work, power must be turned OFF.
31	Power Input Terminal	Terminal (CN7) is for connecting power cable.
32	External Warning Light Power Terminal	Terminal (CN9) is for an Assistance power terminal for external warning light installation.
33	Signal output terminal	Terminal (CN5) is used for Relay Dry Contact Signal such as warning, failure, etc. and connecting Switch Signal Output Cable, etc.
34	Signal I/O terminal	Terminal (CN6) is used for connecting cables for power supply of gas leak detector, 4~20 mA current output, and RS-485 MODBUS Network, etc.

[Table 1. GTC-542 Configuration Description]

- It is prohibited for an individual, other than an approved user or a technician responsible for installation and repair from the head office, to install a gas leak detector on site or open the cover of the installed gas leak detector and manipulate it. This may cause serious loss of life and property from fire, explosion, and etc. In addition, please check whether there is any remaining explosive gas or combustible material in the surroundings. Power must be turned off before performing work.

5.1. Power Configuration

- After detaching the equipment cover, terminal block that connects power and various signals within PCB appears.
- Connect AC Power (85~260 V 50/60 Hz) to CN9 as shown in the figure below.

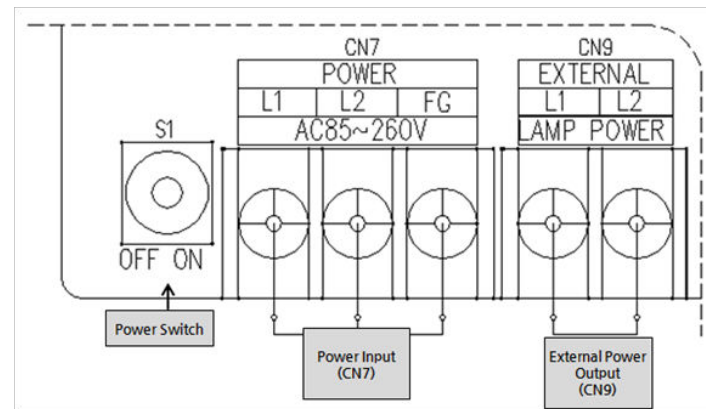

[Figure 2. GTC-542 Power Configuration]

- When it is desired to use DC24V, a separate request must be made when ordering the product. When the product has been delivered as DC24V-Type upon a customer request, (+) and (-) of DC24V shall be connected to L1 and L2 or CN9, respectively.

5.2. Signal Terminal Configuration

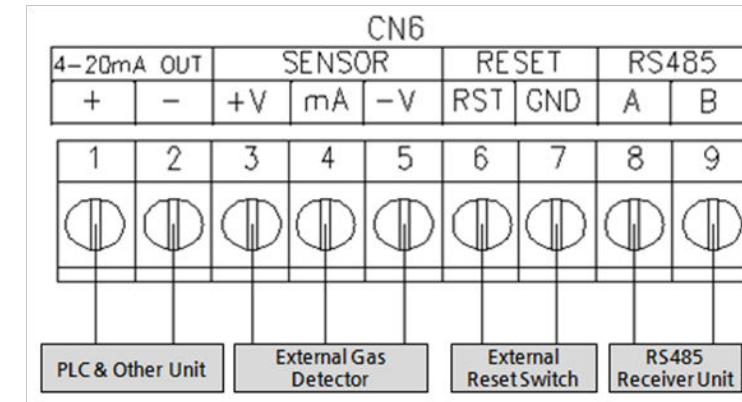

[Figure 3. CN6 Terminal Configuration]

- Using CN6 terminal, connect 4~20 mA output, External Reset, RS485, and external gas detector. Terminal configuration is as shown in the table below.
- RS-485 cable uses a cable designated for RS-485 and cables for 4~20 mA output and detector connection must use a shield cable with CVVS or CVVSB 0.75 sq and higher.

FUNCTION	TERMINAL NAME	DESCRIPTION		
4-20mA Output	VISO	External power input terminal for 4~20 mA Sink Driver		
	mA	Output terminal for 4~20 mA Source Driver		
SENSOR	1	Combustible Sensor	Toxic Sensor	O2 Sensor (Galvanic Method)
	2	Red Cable	Blue Cable	N.C
RESET	+	White Cable	Red Cable	Red Cable
	-	External Reset S/W - Terminal		
RS485	A	External Reset S/W + Terminal. When + and - terminals short, alarm reset function operates.		
	B	External Reset S/W - Terminal		

[Table 2. CN6 Terminal Description]

Note 1) When RS485 Option does not exist, RS485 function does not operate.

5.3. Relay Terminal Configuration

- Using CN5 terminal, it consists of 3 SPDT-type Alarm relay and 1 SPDT-type Trouble relay.
- Alarm Lamp (LP) can connect DC external warning light.
- LP terminal output DC +24V power regardless of AC, DC power mode. This is to use an external DC flash light or external devices.

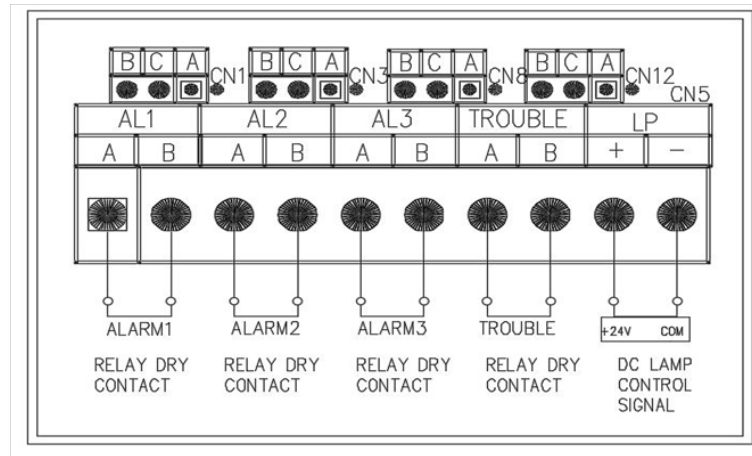

[Figure 4. CN5 Terminal Configuration]

FUNCTION	PIN	TERMINAL NAME	DESCRIPTION
Alarm1	1	A	Alarm1 Normal Open
	2	B	Alarm1 Normal Closed
Alarm2	3	A	Alarm2 Normal Open
	4	B	Alarm2 Normal Closed
Alarm3	5	A	Alarm3 Normal Open
	6	B	Alarm3 Normal Closed
Trouble	7	A	Trouble Normal Open
	8	B	Trouble Normal Closed
LP	9	+	External Power (DC 24 V) + Output
	10	-	External Power (DC 24 V) - Output

[Table 3. CN5 Terminal Description]

5.4. 3-wire Type Gas detector Connection Method

- When the gas detector has 3-wire (V+, mA, V-) for power and 420 mA output components, connect to the Channel Unit as shown in Figure 5.
- Connecting cable must comprise of CVVS or shield cable with CVVSB 0.7 sq or higher.
- Our gas detector models in this type are TS-1100Ex, TS-2000Ex, TS-2100 Series, TS-4000 Series, TS-4100P Series, TS-5100 Series, GTD-1000 Series, GTD-2000 Series, GTD-3000 Series, GIR-3000 Series.

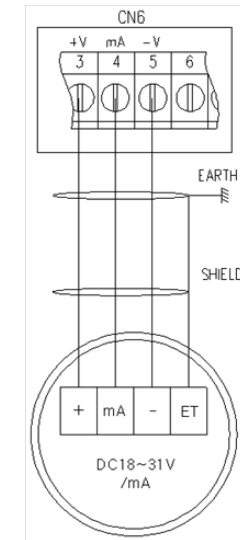

[Figure 5. 3-Wire type gas detector]

5.5. 2-wire type Gas detector Connection Method

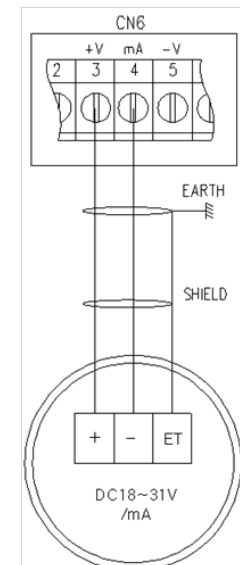

- When the gas detector output has 2-wire (V+, V-), connect to the Channel Unit as shown in Figure 6.
- Connecting cable must comprise of CVVS or shield cable with CVVSB 0.7 sq or higher.
- Our gas detector models in this type are TS-1100Tx, TS-2000Tx, TS-3000 Series, TS-3100 Series.



[Figure 6. 2-Wire type gas detector]

6.1. Power ON

- Check wirings for operation power, detection parts, alarm parts, and concentration display.
- Check the power input then turn ON the power S/W.
- Check whether power LED at alarm and concentration display parts light on.
- Check whether "SELF" is displayed on FND concentration display part.

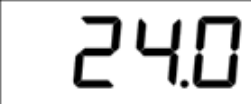

	<ul style="list-style-type: none"> - After GTC-542 power turns ON, the current firm ware version is displayed. - VER is displayed for 0.5 sec on FND then number displays. - The current version is 1.03.
	<ul style="list-style-type: none"> - After warming-up by "SELF" flashing for approx. 30 sec on FND of concentration display, it immediately enters the measurement mode. - Upon an event of fault of the equipment or detector at this time, fault alarm appears.

6.2. Power Display

	<ul style="list-style-type: none"> - After GTC-542 power turns ON, the current firm ware version is displayed. - It displays 24.0 before completion of self test and outputs inputted voltage after the completion. - When "BATTERY TEST" key is pressed with external power applied, it outputs spare battery voltage. - When it operates on spare battery, main power LED turns off and power LED lights on. - When the spare battery is connected properly and there is no problem in charging and usage, BAT.GOOD LED lights on. - When the spare battery is detached, battery key (internal switch) is off, or it is completely discharged, BAT. GOOD LED turns off and BAT.TROUBLE LED lights on.
---	---

6.3. Measuring Mode

- After power on, when there is no error from "SELF TEST", it automatically enters Measuring Mode.

	<ul style="list-style-type: none"> - Displays gas concentration received by the detector on FND digital display in numbers. - Gas concentration is also displayed by 3-color bar graphic LED. Concentrations below the primary alarm concentration in green, below the secondary alarm concentration in orange, and above the secondary alarm concentration in red. - 3-level alarm thresholds are always displayed by 3-color bar graphic LED. Alarm1 threshold in green, Alarm2 threshold in orange, and alarm3 threshold in red.
	<ul style="list-style-type: none"> - When the detector is not connected or input current from the detector is under 10% below the set high scale value, "Undr" displays and flashes at 1 sec interval - Trouble LED lights on, warning light flashes, and buzzer sounds - When buzzer stop key is pressed, the warning light turns on and the buzzer stops.
	<ul style="list-style-type: none"> - When the input current from the detector is over 10% above the set high scale value, "ovE" displays and flashes at 1 sec interval. - Alarm 1, 2, 3 LED lights flickers, warning light flickers, and buzzer sounds. - Top circular LED of the 3-Color bar graphic LED lights on red. - When gas concentration is detected to be above the set value for alarm, alarm function counts the dwell time and if it is above the set dwell time, alarm function operates. - Alarm relay turns on when it is above the alarm dwell time. - When alarm latch type is "ON", upon operation of alarm function, alarm status and gas concentration value are maintained at the max. value. It does not get release when the gas concentration is decreased below the alarm threshold and "RESET" key must be used to release it. - When Alarm Latch Type is OFF, Alarm is released automatically in accordance to gas concentration.

6.4. Test Mode

- Pressing "TEST" S/W for 2 sec or longer in gas concentration display mode enters Test mode.
- In test mode, when it passes 30 min after the last S/W control, it automatically returns to the gas concentration display mode

	<ul style="list-style-type: none"> - When it enters Test mode, gas concentration number displays and flickers. - This function enables testing at channel unit without injecting gas to the detector sensor. It can set an arbitrary concentration when the user presses "Test" S/W and alarm function operates normally with a user-defined concentration. - When "FUNC" S/W is pressed 2 sec or longer, it enters FND / LED / Bar LED Test function. - 3-Color bar graph LED displays green, orange, and red at 0.5 s interval and each function LED flickers at 0.5 s interval. - When "RESET" S/W is pressed, it returns to gas concentration display mode.
---	--

6.5. Stand-by Mode

- Pressing "DOWN" S/W for 2 sec or longer in gas concentration display mode enters Stand-by mode.
- When ETO (Emergency Time Out) is set to ON in Option Setting Mode, it automatically returns to gas concentration display mode after 30 min.
- When ETO is OFF, "DOWN(Stand-by)" S/W must be pressed 2 sec or longer to return to gas concentration display mode.



- In stand-by mode, STD-BY LED flickers. Trouble/Alarm relay of GTC-542 contact output does not operate but all other functions run.
- When "DOWN(Stand-by)" KEY is pressed 2 sec or longer, it returns to gas concentration display mode

6.6. Operation Setting

6.6.1. Setting Table

LEVEL1	LEVEL2	PARAMETER	DEFAULT
PROGRAM MODE 	d995 (Gas Funtion)	TY1, Ty2, TY3, TY4	TY1
	d-P5 (Decimal-Point)	100, 1.00, 10.0, 0.100	100
	H-5L (High-Scale)	10~9999	100
	5Pd	-99 ~ 99	0
	PR55 (Pass Word)	0~99	00
	o-5 (Out-Set)	ON, OFF	OFF
	End (End)	-	-
	ALARM MODE 	LACH (LACH)	ON, OFF
En5 (Energizer)		ON, OFF	OFF
ALP (Alarm Lamp)		ON, OFF	ON
RL-1 (Alarm-1)		1~Full range	20%/F.R.
1H (1H)		H, L	H
1H00 (1H 00)		0~99	00
RL 1E (Alarm 1 Time Delay)		0~60	1
R 1rL (Alarm 1 Relay)		ON, OFF	ON
R 1bL (Alarm 1 Blink)		ON, OFF	OFF
RL-2 (Alarm-2)		1~Full range	40%/F.R.
2H (2H)		H, L	H

LEVEL1	LEVEL2	PARAMETER	DEFAULT
ALARM MODE 	2H00 (2H 00)	0~99	00
	RL 2E (Alarm 2 Time Delay)	0~60	1
	R 2rL (Alarm 2 Relay)	ON, OFF	ON
	R 2bL (Alarm 2 Blink)	ON, OFF	OFF
	RL-3 (Alarm-3)	1~Full range	50%/F.R.
	3H (3H)	H, L	H
	3H00 (3H 00)	0~99	00
	RL 3E (Alarm 3 Time Delay)	0~60	1
	R 3rL (Alarm 3 Relay)	ON, OFF	ON
	R 3bL (Alarm 3 Blink)	ON, OFF	OFF
	End (End)	-	-
	Option MODE 	n-L (Maintenance-Level)	0 ~ Full range
Undr (Under)		ON / OFF	OFF
En9 (Engineering)		ON / OFF	OFF
2-5 (Zero-Skip)		0 ~ 20.0%	0
5-5 (Span-Skip)		0 ~ 20.0%	0
Et0 (Emergency-Timeout)		ON / OFF	OFF
odt (Outout Delay Time)		0 ~ 60	0
odu (Outout Delay Value)		0 ~ 20	0
Test MODE 	End (End)	-	-
	ErLY (Trouble Relay)	ON / OFF	OFF
	RrLY (Alarm Relay)	ON / OFF	OFF
	RouE (mA out)	ON / OFF	OFF
485 MODE 	(0 or 100)	0 or 100 (Flickering)	When ON, starts from 100 When OFF, starts from 0
	CHno (Channel number)	0~128	1
	PRr (Parity Bit)	0~2	1

[Table 4. Mode Setting Table]

6.6.2. PROGRAM MODE

- After setting password, press "▲" KEY or "▼(Test)" KEY to move then press "FUNC" KEY to enter.
- In program setting mode, when it passes 10 sec after the last KEY control, it automatically returns to gas concentration display mode.

	<ul style="list-style-type: none"> - When "FUNC" S/W is pressed, it enters Program Mode. - When "RESET" S/W is pressed, it returns to gas concentration display mode.
	<ul style="list-style-type: none"> - It is decimal position setting mode, which is the first function in program data setting mode. - When "FUNC" S/W is pressed, it enters decimal setting mode. - When "RESET" S/W is pressed, it returns to Program Mode.
	<ul style="list-style-type: none"> - For each TY selection, High-Scale, d-PS, Alarm (1, 2, 3), Alarm direction, Stand-by mode output, Sensor output characteristic direction, Temperature compensation functions change accordingly.
	<ul style="list-style-type: none"> - Decimal point position is set by pressing "▲" KEY or "▼(Test)" KEY where it changes as shown on the left. (Default TY1) - Value that changes upon TY1 selection (Ex. Tx) - Decimal position setting -> Default 0, Max. gas concentration display possible -> Default 100 - Alarm threshold 1 -> 20 H, 2 -> 40 H, 3 -> 50 H - Stand-by output -> Default 0, Sensor output characteristic direction -> Default dec - Temperature compensation function -> Default OFF
	<ul style="list-style-type: none"> - Value that changes upon TY2 selection (Membrapor O2) - Decimal position setting -> 1 (25.0) Max. gas concentration display possible -> 250 - Alarm threshold 1 -> 18.0 L, 2 -> 15.0 L, 3 -> 23.0 H - Stand-by output -> Default 20.9, Sensor output characteristic direction -> Default inc - Temperature compensation function -> Default ON
	<ul style="list-style-type: none"> - TY3 and TY4 are back up and not used currently. - When a desired TY is displayed, press "FUNC" KEY to set TY and enter the next item. - When "RESET" KEY is pressed, it returns Program Mode.
	<ul style="list-style-type: none"> - It is decimal position setting mode, which is the first function in program data setting mode. - When "FUNC" KEY is pressed, it enters decimal setting mode. - When "RESET" KEY is pressed, it returns to Program Mode.

	<ul style="list-style-type: none"> - Decimal point is used when it is necessary to change decimal point for measured range. Decimal point position is set by pressing "▲" KEY or "▼(Test)" KEY where it changes as shown on the left. (Default 100)
	<ul style="list-style-type: none"> - Ex) 100, 10.0, 1.00
	<ul style="list-style-type: none"> - When a desired decimal place is displayed, press "FUNC" KEY to set the decimal place and enter the next item. - When "RESET" KEY is pressed, it returns Program Mode.
	<ul style="list-style-type: none"> - It is High scale setting mode, which sets the max. gas concentration to be displayed. - High scale value is set in accordance to the domestic regulations as factory setting. - When "FUNC" KEY is pressed, it enters high scale setting mode. - When "RESET" KEY is pressed, it returns Program Mode.
	<ul style="list-style-type: none"> - High scale changes a set value according to measuring range. Scale value increases or decreases upon pressing "▲" KEY or "▼(Test)" KEY, respectively. (Default 100)
	<ul style="list-style-type: none"> - When a desired high scale is displayed, press "FUNC" KEY to set it and enter the next item. - When "RESET" KEY is pressed, it returns Program Mode. - This setting mode is configured with the same measuring range as gas detector when delivered. Ex.) When range is set to 100.
	<ul style="list-style-type: none"> - For 4 mA/DC output ... 0 Display For 20 mA/DC output ... 100 Display - SAD setting mode to correct measurement error occurring from the detector. - Pressing "FUNC" KEY enters SAD value setting function. - When "RESET" KEY is pressed, it returns Program Mode.

-99	- Function to set SAD value. SAD value increase or decreases when "▲" KEY or "▼(Test)" KEY is pressed, respectively. For negative value, "-" sign displays above the first digit. (Default 0)
99	- When a SAD value is displayed, press "FUNC" KEY to set and enter the next item. - When "RESET" KEY is pressed, it returns Program Mode. (Ex.) When output error at detector is -2, the actual display should be -2, but SAD set value of 2 is corrected and 0 is displayed.
PAS	- Password setting function. - When "FUNC" S/W is pressed, it enters Password setting mode. - When "RESET" S/W is pressed, it returns to Program Mode.
P00	- Password value increases or decreases when "UP" S/W or "DOWN" S/W is pressed, respectively. (Default P00)
P99	- When a desired password no. is displayed, press "FUNC" S/W to set it and enter the next item. - When "RESET" S/W is pressed, it returns to Program Mode.
o-5	- It is used when two or more receiver are used. - When receiver 2 receives mA output from receiver 1, mA for each function entered to receiver 2 instead of the actual gas value when entering function and test modes. This function is to prevent the alarm operation coming from this. - When "FUNC" KEY is pressed, it enters Out-Set setting mode. - When "RESET" KEY is pressed, it returns Program Mode.
on	- "ON" and "OFF" mode changes by pressing "▲" KEY or "▼(Test)" KEY. (Default OFF) - When "ON", the current gas value is calculated and outputted in mA. Even when it is set to each mode or test mode, it displays gas value that is not a defined mA.
off	- When "OFF", as the same as the existing setting, it displays the current gas value in gas concentration display mode and defined mA when entering each mode. - When a desired o-s function is displayed, press "FUNC" KEY to set password no. and enter the next item. - When "RESET" KEY is pressed, it returns Program Mode.

End

- A message indicating completion of setting is displayed as "End" for 2 sec then it returns to gas concentration display status.

6.6.3. ALARM Mode

- After setting a password, move to "UP" S/W or "DOWN" S/W then press "FUNC" S/W to enter the mode.
- In Alarm setting function, when it passes 10 sec after the last S/W control, it automatically returns to gas concentration display mode.

ALA

- It can designated threshold for Alarm1, Alarm2, and Alarm3.
- When "FUNC" S/W is pressed, it enters Alarm setting mode.
- When "RESET" S/W is pressed, it returns to gas concentration display mode.

LAC

- It is a mode that sets Alarm Latch Type.
- When "FUNC" S/W is pressed, it enters Alarm Latch Type setting mode.
- When "RESET" S/W is pressed, it returns to Alarm Setting Mode.

on

- It is a mode to change alarm reset type and "ON" and "OFF" mode changes when "UP" or "DOWN" S/W are pressed.
- When a desired alarm latch type is displayed, press "FUNC" S/W to set it and enter the next item.
- When "RESET" S/W is pressed, it returns to Alarm Setting Mode.

off





- Alarm Latch Type has two modes: "ON" and "OFF". "OFF" mode automatically resets alarm.
- When "ON", the user must press "RESET" S/W to release and reset the alarm.

ENS

- It is a function that sets Energizer Modes for Alarm Relay and Fault Relay.
- When "FUNC" S/W is pressed, it enters Energizer Mode setting function.
- When "RESET" S/W is pressed, it returns to Alarm Setting Mode.

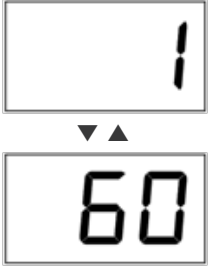
	<ul style="list-style-type: none"> - Energizer mode decides ON/OFF using "▲" KEY or "▼(Test)" KEY. - When ON, it is in Normal Open (NO) status. - When OFF, it is in Normal Close (NC) status. - When a desired energizer mode is displayed, press "FUNC"KEY to set it and enter the next item. - When "RESET" KEY is pressed, it returns to Setting Mode.
	<ul style="list-style-type: none"> - Mode that sets external warning lights to operate with a desired alarm. - When "FUNC" KEY is pressed, it enters alarm lamp setting mode. - When "RESET" KEY is pressed, it returns Setting Mode.
	<ul style="list-style-type: none"> - Using "▲"KEY or "▼(Test)" KEY to display a desired alarm, then press "FUNC" key to set it. By default, it is set at "ON". - When Alarm goes off when Alarm Lamp is ON, warning light lights on. When it is OFF, warning light is off. - When a ALP value is displayed, press "FUNC"KEY to set and enter the next item. - When "RESET"KEY is pressed, it returns Setting Mode.
	<ul style="list-style-type: none"> - Alarm 1 threshold setting function message is displayed as "AL-1" - When "FUNC" KEY is pressed, it enters Alarm1 threshold setting mode. - When "RESET" KEY is pressed, it returns Setting Mode.
	<ul style="list-style-type: none"> - Function to change Alarm 1 threshold setting. Max. allowable is high scale value. - Pressing "▲" KEY or "▼(Test)" KEY increases or decreases Alarm1 value, respectively. - When a desired alarm 1 threshold is displayed, press "FUNC" KEY to set it and enter the next item. - When "RESET" KEY is pressed, it returns Setting Mode. - (Default: Alarm1 = 20(F/S 20%), Alarm2 = 40(F/S 40%), Alarm3 = 50(F/S 50%))

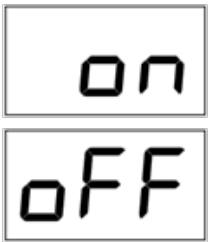
	<ul style="list-style-type: none"> - Alarm level is set to the concentration outlined in domestic regulations as factory setting. - It is a mode to set a direction of Alarm 1 operation. Pressing "UP" S/W or "DOWN" S/W displays "H" or "L", respectively. - "H" mode operates when gas value is equal or greater than Alarm1 setting value. "L" mode operates when gas value is equal or less than Alarm1 set value. - When a desired mode is displayed, press "FUNC" S/W to set it and enter the next item. - When "RESET" S/W is pressed, it returns to Alarm Setting Mode.
	<ul style="list-style-type: none"> - It is a mode to set a dead band for Alarm 1 operation. Pressing "UP" S/W or "DOWN" S/W increases or decrease the value, respectively. (Default 0) - When Alarm 1 is in "H" mode, Alarm 1 operates at values above the sum of Alarm and dead band values and releases below the sum. - When Alarm 1 is in "L" mode, Alarm 1 operation below difference of Alarm and dead band values and releases above the difference - When a desired Alarm1 dead band value is displayed, press "FUNC" S/W to set it and enter the next item. - When "RESET" S/W is pressed, it returns to Alarm Setting Mode.
	<ul style="list-style-type: none"> - It is a mode to set Alarm1 dwell time. - It is a function to prevent instantaneous malfunction of detector due to external shock and noise other than from normal operation. - Press "FUNC" S/W to enter Alarm 1 delay time setting function. - When "RESET" S/W is pressed, it returns to Alarm Setting Mode.

	<ul style="list-style-type: none"> - To change Alarm 1 delay time, pressing "UP" S/W or "DOWN" S/W increases or decreases the time in unit of seconds (Default 1) Ex.) Alarm Threshold Value: 20%LEL/delay Time: When it is at 5 sec, Alarm triggers when the measured value is above the set value based on 20%LEL for 5 sec or longer. When it goes down below the set value within 5 sec, alarm is not triggered. - When a desired Alarm 1 delay time is displayed, press "FUNC" S/W to set it and enter the next item. - When "RESET" S/W is pressed, it returns to Alarm Setting Mode.
	<ul style="list-style-type: none"> - It is a mode to set Alarm1 contact output. - Press "FUNC" S/W to enter Alarm 1 contact output setting function. - When "RESET" S/W is pressed, it returns to Alarm Setting Mode.
	<ul style="list-style-type: none"> - It is a mode to change Alarm1 contact output and "ON" and "OFF" mode changes when "ON" or "OFF" S/W are pressed. - Alarm1 contact output mode has two modes; "ON" and "OFF". In OFF mode, Alarm 1 contact output does not run. In ON mode, it runs. - When a desired Alarm 1 contact output mode is displayed, press "FUNC" S/W to set it and enter the next item. - When "RESET" S/W is pressed, it returns to Alarm Setting Mode.
	<ul style="list-style-type: none"> - Alarm 1 blink output setting function that sets Alarm1 contact output to go ON/OFF at 1 sec interval during buzzer operation. - Press "FUNC" S/W to enter Alarm 1 blink output setting function. - When "RESET" S/W is pressed, it returns to Alarm Setting Mode.
	<ul style="list-style-type: none"> - It is a mode to change Alarm1 blink output and "ON" and "OFF" mode changes when "ON" or "OFF" S/W are pressed. - Alarm1 blink output mode has two modes; "ON" and "OFF". In OFF mode, Alarm 1 blink output does not run. In ON mode, it runs. (However, it runs when Alarm1 contact output mode is ON.) - When a desired Alarm 1 blink output mode is displayed, press "FUNC" S/W to set it and enter the next item. - When "RESET" S/W is pressed, it returns to Alarm Setting Mode.



- A message indicating completion of setting is displayed as "End" for 2 sec then it returns to gas concentration display status.

* Alarm 2 and Alarm 3 setting modes are the same as Alarm 1.

6.6.4. Option Mode (Option setting)

- After setting a password, move to "UP" S/W or "DOWN" S/W then press "FUNC" S/W to enter the mode.
- In Option setting mode, when it passes 10 sec after the last S/W control, it automatically returns to gas concentration display mode.
- In option mode, most settings are factory preset, therefore, this function should not be adjusted. When it is unavoidable, the user must seek help from GasTron to adjust.



- It is a mode to set Option function.
- When "FUNC" S/W is pressed, it enters Option setting mode.
- When "RESET" S/W is pressed, it returns to gas concentration display mode.

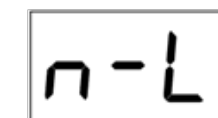

- It is a mode to set FND display and output value when it is in Stand-by Mode.
- Press "FUNC" S/W to enter n-L setting function.
- When "RESET" S/W is pressed, it enters Option Setting Mode.



Full Range

- By pressing "UP" S/W and "DOWN" S/W, it can be set in full range.
(Default: 0 Oxygen : 20.9(Ex., Setting 0 : 4mA, Full Range : 20mA))
- When a desired n-L value is displayed, press "FUNC" S/W to set it and enter the next item.
- When "RESET" S/W is pressed, it enters Option Setting Mode.



- Item to set whether to use a function that displays Undr on FND when a negative value is below -10%.
- When "FUNC" S/W is pressed, it enters Under setting mode.
- When "RESET" S/W is pressed, it enters Option Setting Mode.

	<ul style="list-style-type: none"> - By pressing "UP" S/W or "DOWN" S/W, ON/OFF status can be set and when it is ON, UNDER function is available for use. (Default OFF) - When a desired item is displayed, press "FUNC" S/W to set it and enter the next item. - When "RESET" S/W is pressed, it enters Option Setting Mode.
	<ul style="list-style-type: none"> - For measurement display, it displays raw data from -XXXX ~ +YYYY. - When "FUNC" S/W is pressed, it enters "Engineer" setting mode. - When "RESET" S/W is pressed, it enters Option Setting Mode. - (This mode is only used as test mode and is not used in the actual field.)
	<ul style="list-style-type: none"> - By pressing "UP" S/W or "DOWN" S/W, ON/OFF status can be set and when it is ON, the function is available for use. (Default OFF)
	<ul style="list-style-type: none"> - When a desired item is displayed, press "FUNC" S/W to set it and enter the next item. - When "RESET" S/W is pressed, it enters Option Setting Mode.
	<ul style="list-style-type: none"> - Item for zero skip setting. - It zero skips the value designated for high scale setting range. - When "FUNC" KEY is pressed, it enters Z-S setting mode. - When "RESET" KEY is pressed, it returns to Option Setting Mode.
	<ul style="list-style-type: none"> - It can set in 0~20 (%) range using "▲" KEY or "▼(Test)" KEY.
	<ul style="list-style-type: none"> - When a desired value is displayed, press "FUNC" KEY to set and enter the next item. - When "FUNC" KEY is pressed, it enters Option Setting Mode.
	<ul style="list-style-type: none"> - Item for span skip setting. - It span skips the value designated for high scale setting range. - When "FUNC" KEY is pressed, it enters S-S setting mode. - When "FUNC" KEY is pressed, it enters Option Setting Mode.

	<ul style="list-style-type: none"> - It can set in 0~20 (%) range using "▲" KEY or "▼(Test)" KEY.
	<ul style="list-style-type: none"> - When a desired value is displayed, press "FUNC" KEY to set and enter the next item. - When "FUNC" KEY is pressed, it enters Option Setting Mode.
	<ul style="list-style-type: none"> - It sets Emergency Time Out. In stand-by mode, the user can decide whether to set the time. - When "FUNC" KEY is pressed, it enters Emergency Time Out setting mode. - When "RESET" KEY is pressed, it returns to Option Setting Mode.
	<ul style="list-style-type: none"> - By pressing "▲" KEY or "▼(Test)" KEY, ON/OFF status can be set. When it is ON, mode time runs for 30 min and when it is OFF, stand-by mode time continuously runs without limit. (Default OFF)
	<ul style="list-style-type: none"> - When a desired item is displayed, press "FUNC" KEY to set and enter the next item. - When "RESET" KEY is pressed, it returns to Option Setting Mode.
	<ul style="list-style-type: none"> - It sets output delay time - Gas value within time and value applied by operating with output delay value is not displayed. - When the value exceeds, the measurement is displayed. - When "FUNC" KEY is pressed, it enters Output Delay Time setting mode. - When "FUNC" KEY is pressed, it enters Option Setting Mode.
	<ul style="list-style-type: none"> - It can set in 0~60 (sec) range using "▲" KEY or "▼(Test)" KEY.
	<ul style="list-style-type: none"> - When a desired value is displayed, press "FUNC" KEY to set and enter the next item. - When "FUNC" KEY is pressed, it enters Option Setting Mode. ※ odt and odv settings operate by referencing each other.

	<ul style="list-style-type: none"> - It sets output delay value. - Gas value within time and value applied by operating with output delay time is not displayed. When the value exceeds, the measurement is displayed. - When "FUNC" S/W is pressed, it enters Output Delay value setting mode. - When "FUNC" KEY is pressed, it enters Option Setting Mode.
	<ul style="list-style-type: none"> - It can set in 0~20 (%) range using "▲" KEY or"▼(Test)" KEY. - When a desired value is displayed, press "FUNC" KEY to set and enter the next item. - When "FUNC" KEY is pressed, it enters Option Setting Mode. - odt and odv settings operate by referencing each other.
	<ul style="list-style-type: none"> - A message indicating completion of setting is displayed as "End" for 2 sec then it returns to gas concentration display status.

6.6.5. Test Mode

- After setting a password, move to "UP" S/W or "DOWN" S/W then press "FUNC" S/W to enter the mode.
- In test mode, when it passes 10 sec after the last S/W control, it automatically returns to gas concentration display mode.



	<ul style="list-style-type: none"> - Test mode enables testing without injecting gas to the detector sensor. The user can set an arbitrary concentration by pressing "▲" KEY or"▼(Test)" KEY and the alarm function operates normally with a user-defined concentration. - Pressing "FUNC" KEY enters Test setting function. - When "RESET" KEY is pressed, it returns to gas concentration display mode
	<ul style="list-style-type: none"> - It is a mode that sets ON/OFF status for Test Relay Test Operation. - When "FUNC" KEY is pressed, it enters Test Relay setting mode. - When "RESET" KEY is pressed, it returns to Test Setting Mode.

	<ul style="list-style-type: none"> - By pressing "▲" KEY or"▼(Test)" KEY, ON/OFF status can be set and when it is ON, Test Relay function is available for use. (Default OFF) - When a desired item is displayed, press "FUNC" KEY to set and enter the next item. - When "RESET" KEY is pressed, it returns to Test Setting Mode.
	<ul style="list-style-type: none"> - It is a mode that sets ON/OFF status for Alarm Relay Test Operation. - When "FUNC" KEY is pressed, it enters alarm FUNC setting mode. - When "RESET" KEY is pressed, it returns to Test Setting Mode.
	<ul style="list-style-type: none"> - By pressing "▲" KEY or"▼(Test)" KEY, ON/OFF status can be set and when it is ON, Test Relay function is available for use. (Default OFF) - When a desired item is displayed, press "FUNC" KEY to set and enter the next item. - When "RESET" KEY is pressed, it returns to Test Setting Mode.
	<ul style="list-style-type: none"> - It is mA Output Signal Test Mode. - When "FUNC" KEY is pressed, it enters mA output setting mode. - When "RESET" KEY is pressed, it returns to Test Setting Mode.
	<ul style="list-style-type: none"> - By pressing "▲" KEY or"▼(Test)" KEY, ON/OFF status can be set and when it is ON, Test Relay function is available for use. (Default OFF) - When a desired item is displayed, press "FUNC" KEY to set and enter the next item. - When "RESET" KEY is pressed, it returns to Test Setting Mode.

 <p style="text-align: center;">▼ ▲ Full Range</p>	<ul style="list-style-type: none"> - When Aout is OFF, it starts from 0. FND value is changed by "UP" S/W or "DOWN" S/W but mA is not outputted. (Default 3mA) - When Aout is ON, FND value outputs from 100 and output current is 20 mA. It can be changed by "UP" S/W or "DOWN" S/W. - (FND: 0~100, mA : 4mA~20mA) - When "FUNC" S/W is pressed, it returns to Test Mode Setting Mode. - The current test mode is set to output for 1 h after the last KEY operation. After completion of test, press "FUNC" KEY or "RESET" KEY to return to Test Mode Setting Mode.
---	---

6.6.6. 485 Setting Mode

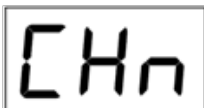
- After setting a password, move to "UP" S/W or "DOWN" S/W then press "FUNC" S/W to enter the mode.
- In 485 mode, when it passes 10 s after the last S/W control, it automatically returns to gas concentration display mode.

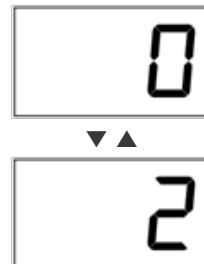

	<ul style="list-style-type: none"> - It is a mode that sets 485 function. - When "FUNC" S/W is pressed, it enters 485 setting mode. - When "RESET" S/W is pressed, it returns to gas concentration display mode.
	<ul style="list-style-type: none"> - It is channel Number Setting Function that sets Serial Number of Control Unit. - Press "FUNC" S/W to enter Channel number setting function. - When "RESET" S/W is pressed, it returns to 485 Mode.
	<ul style="list-style-type: none"> - Channel number is a mode that enters serial number of control unit to enable recognition of operation status of each control unit at other equipment, such as PC, etc. Pressing "UP" S/W or "DOWN" S/W increase or decreases Address No. Value, respectively. (Default 1) - When a desired address no. is displayed, press "FUNC" S/W to set it and enter the next item. - Channel No is set at "1" as factory preset and is only entered when network function is to be used. When two or more control unit is used, Channel No. shall not overlap.

	<ul style="list-style-type: none"> - Mode that sets Parity Bit, which is a format of 485 communication. - When "FUNC" KEY is pressed, it enters Parity Bit setting mode. - When "RESET" KEY is pressed, it returns to gas concentration display mode
	<ul style="list-style-type: none"> - It is a mode that sets ON/OFF status for Test Relay Test Operation. - When "FUNC" KEY is pressed, it enters Test Relay setting mode. - When "RESET" KEY is pressed, it returns to Test Setting Mode.

6.6.7. Maintenance Mode

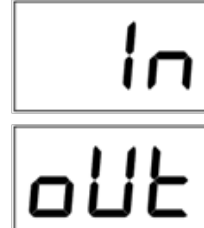
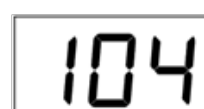
- Pressing both "RESET" and "TEST" S/W for 2 sec or longer in gas concentration display mode enters Maintenance mode.
- "RESET" S/W must be pressed in Maintenance mode to return to gas concentration display mode.

	<ul style="list-style-type: none"> - Mode that selects function to set current input and output values that are reference of Channel unit. Pressing "UP" S/W or "DOWN" S/W displays "In" or "oUt", respectively. - When a desired mode is displayed, press "FUNC" S/W to set it and enter the mode. - When "In" is selected, mode sets current input. When "oUt" is selected, mode sets current output. - When "RESET" S/W is pressed, it returns to gas concentration display mode.
	<ul style="list-style-type: none"> - It is when "In" is selected and a mode that sets by inputting 4 mA current. - Press "FUNC" S/W to enter function that displays current input by number. - When "RESET" S/W is pressed, it returns to gas concentration display mode.

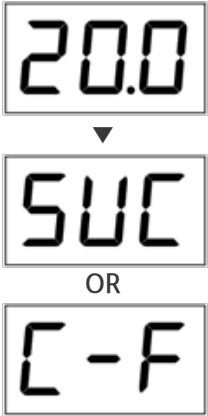
	<ul style="list-style-type: none"> - It is a mode that displays value converted from processor after inputting 4mA current to (mA) terminal. - Press "FUNC" S/W when the displayed number is stable to display SUC (Success) for a current input within normal range and move to the next item. - C-F (Calibration-Fail) displays when a current out of range is inputted. After confirming input current after re-display of current value then press "FUNC" S/W again to confirm. - When "RESET" S/W is pressed, it returns to gas concentration display mode.
	<ul style="list-style-type: none"> - Mode that sets by inputting 20 mA current. - Press "FUNC" S/W to enter function that displays current input by number. - When "RESET" S/W is pressed, it returns to gas concentration display mode.
	<ul style="list-style-type: none"> - It is a mode that displays value converted from processor after inputting 20mA current to (mA) terminal. - Press "FUNC" S/W when the displayed number is stable to display SUC (Success) for a current input within normal range and move to the next item. - C-F (Calibration-Fail) displays when a current out of range is inputted. After confirming input current after re-display of current value then press "FUNC" S/W again to confirm. - When "RESET" S/W is pressed, it returns to gas concentration display mode.

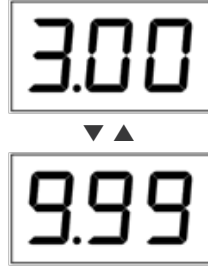
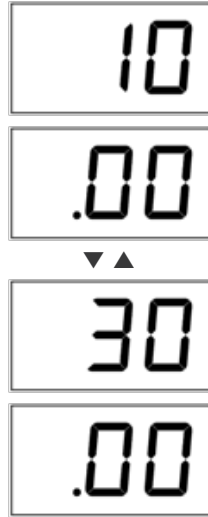
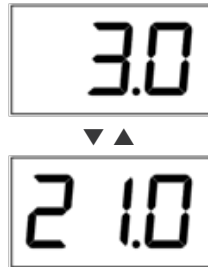
	<ul style="list-style-type: none"> - When "oUt" is selected, it is a mode after input current, which sets 4 mA output current. (Default 4.00) - Connect ammeter to 4~20 mA output terminal and press "▲" KEY or "▼(Test)" KEY to match the values on ammeter and FND then press "FUNC" KEY to set output current and move to the next item. - When "RESET" key is pressed, it returns to gas concentration display mode.
	<ul style="list-style-type: none"> - Mode that sets 20 mA output current. (Default 20.00) - Due to display limit of FND, 10-digit and decimal point digit flashes in 0.5 sec interval. - Connect ammeter to 4~20 mA output terminal and press "▲" KEY or "▼(Test)" KEY to match the values on ammeter and FND then press "FUNC" KEY to set output current and move to the next item. - When "RESET" key is pressed, it returns to gas concentration display mode.
	<ul style="list-style-type: none"> - It is a mode that tests output current after calibration. (Default 4.0) - It can confirm a range for 3.0 mA - 21.0 mA with "▲" KEY or "▼(Test)" KEY. - Pressing "FUNC" KEY after confirmation goes to the next item. - When "RESET" key is pressed, it returns to gas concentration display mode



- A message indicating completion of setting is displayed as "End" for 2 sec then it returns to gas concentration display status.

6.6.8. Factory Initialization Mode

- By pressing "FUNC" S/W + "UP" S/W + "DOWN" S/W and turning ON power, it enters the mode.
- Factory initial is a mode that resets the data to the original factory setting.
- In factory initialization mode, most settings are factory preset, therefore, this function should not be adjusted. When it is unavoidable, the user must seek help from GasTron to adjust.

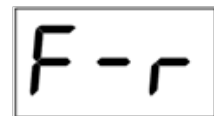

- It is a mode that resets the current saved data to the original factory setting.
- When "RESET" S/W is pressed, it returns to gas concentration display mode.

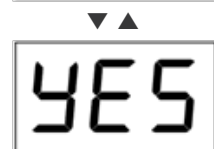

- Press "FUNC" KEY to enter.
- By pressing "▲" KEY or "▼(Test)" KEY, Yes/ No status can be set and when it is in Test, Factory Initialization Function can be used. (Default "no")
- When "RESET" key is pressed, it returns to gas concentration display mode

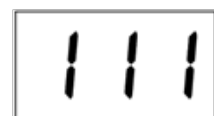
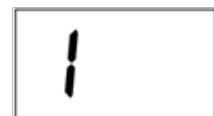

- It is a function that uses "FUNC" KEY, therefore, there are cases where KEY is pressed repeatedly.
- To prevent this, when "FUNC" KEY is used for Yes/no, FND displays "1" -> "11" -> "111" from the left in 0.5 sec interval.
- When "YES" is selected, initialization is complete and it returns to gas concentration display mode.
- When "no" is selected, it returns to gas concentration display mode without initialization.
- Selecting "RESET" KEY returns to gas concentration display mode without FND display.

6.6.9. Calibration Data Initialization Mode

- By pressing "FUNC" S/W + "DOWN" S/W and turning ON power, it enters the mode.
- Calibration Initialization only resets calibration value to factory setting.

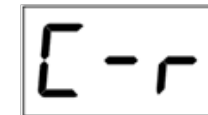

- It is a mode that resets only calibration data from the currently saved data to the original factory setting.
- When "RESET" S/W is pressed, it returns to gas concentration display mode.

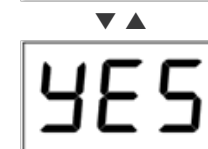

- Press "FUNC" S/W to enter.
- By pressing "UP" S/W or "DOWN" S/W, Yes/no status can be set. When it is "Yes", Calibration Initialization function can be used. (Default "no")
- When "RESET" S/W is pressed, it returns to gas concentration display mode.

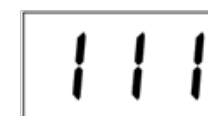
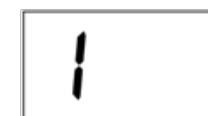

- It is a function that uses "FUNC" S/W, therefore, there are cases where S/W is pressed repeatedly.
- To prevent this, when "FUNC" KEY is used for Yes/no, FND displays "1" -> "11" -> "111" -> "1111" from the left in 0.5 sec interval.
- When "YES" is selected, initialization is complete and it returns to gas concentration display mode.
- When "no" is selected, it returns to gas concentration display mode without initialization.
- Selecting "RESET" S/W returns to gas concentration display mode without FND display.

7.1. MODBUS RS485

7.1.1. Interface setting

- Data Format: RTU
- Baud rate: 9600 bps
- Data bits: 8bits
- Stop bit: 1bits
- Parity: Even
- For details, please go to www.modbus.org

7.1.2. MODBUS RS485 Register map

TYPE	ADDRESS	BITS	DESCRIPTION
Measured Gas Concentration	30001	BIT15~0	Gas Measurement (Integer/Decimal point is not considered)
High Scale Setting	30002	BIT15~0	High Scale Setting (Integer/Decimal point is not considered)
Alarm 1 Setting	30003	BIT15~0	Alarm 1 Setting (Integer/Decimal point is not considered)
Alarm 2 Setting	30004	BIT15~0	Alarm 2 Setting (Integer/Decimal point is not considered)
Gas detector status value	10000	BIT0	Alarm 1 Active Status
		BIT1	Alarm 2 Active Status
		BIT2	Fault Active Status
		BIT3	Maintenance Mode Status
		BIT4	Test Mode Status
		BIT5	Calibration Mode Status
		BIT6	Reserved
		BIT7	Toggle Bit (Bit reversal in 2 sec interval)
External Test	3	BIT0~7	Gas Detector Test Mode Setting
External Reset	2	BIT0~7	Exit Gas Detector Test Mode

[Table 5. RS485 MODBUS Address Configuration]

8.1. Drawing 1

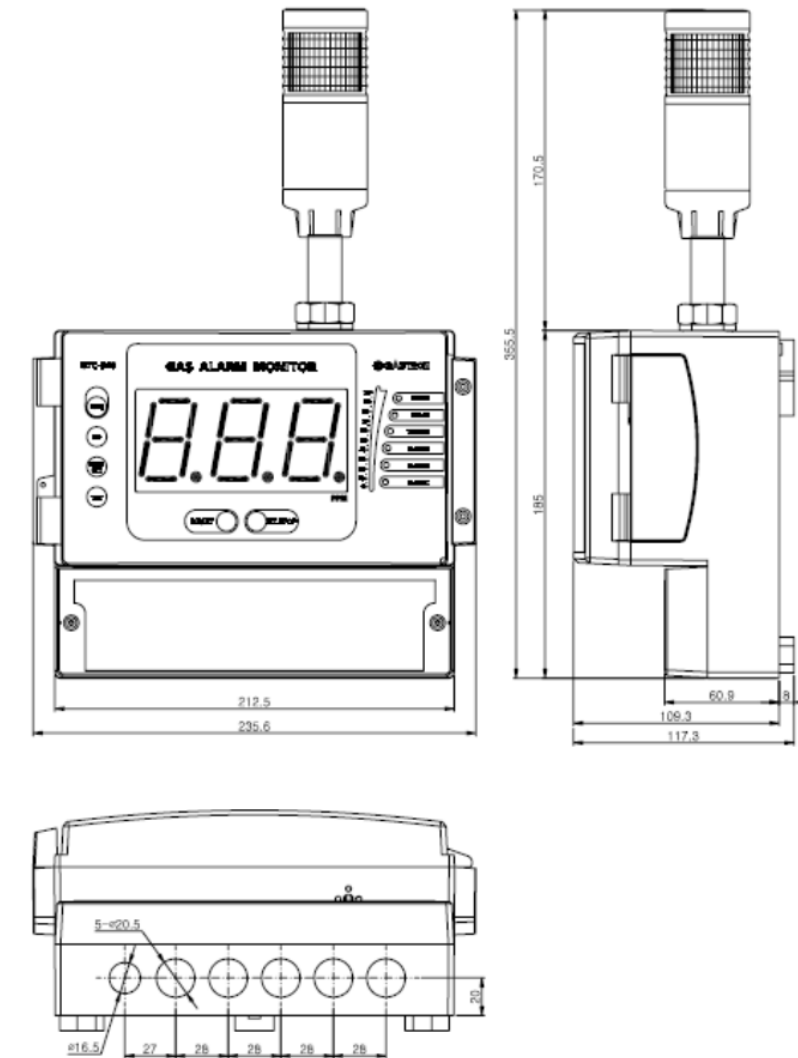

[Figure 7. GTC-542 Drawing 1]

8.2. Drawing 2

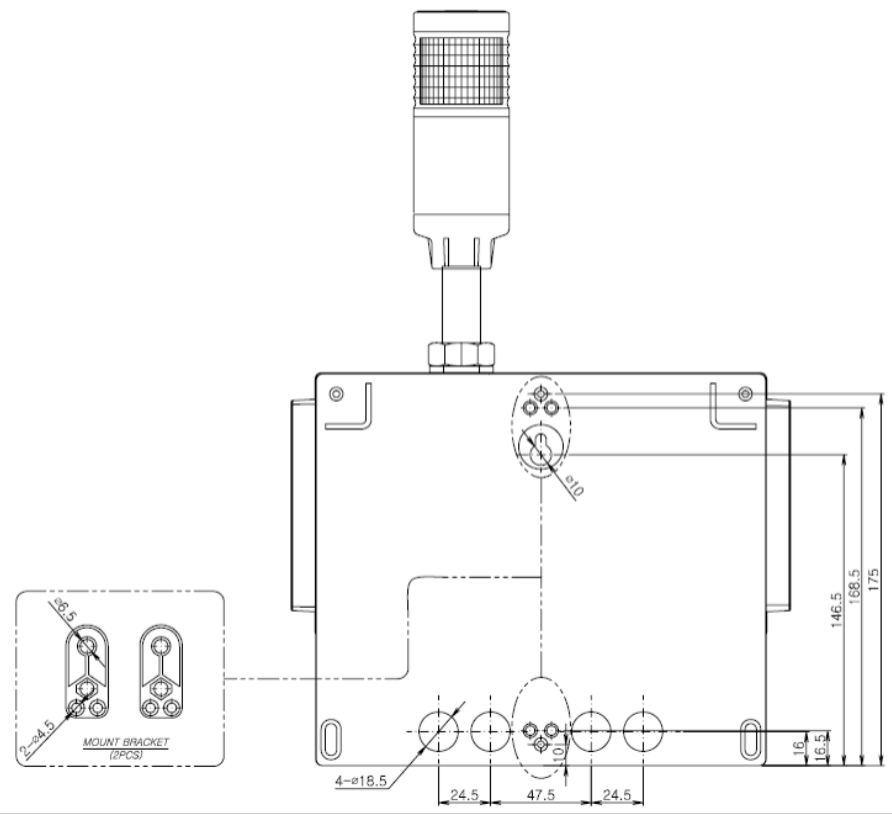

[Figure 8. GTC-542 Drawing 2]

VERSION	CONTENTS	DATE
1.0	Initial Revision of Manual	2016. 09. 23