

LOCAL TOXIC GAS DETECTOR (GTD-1000Tx) LAYOUT & DIMENSIONAL DWG.

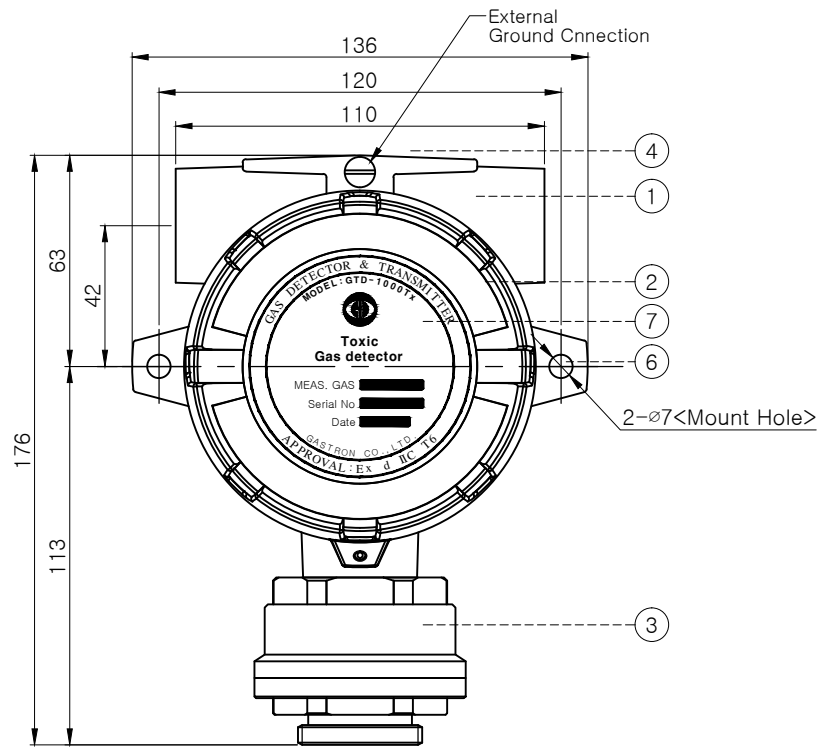

FRONT VIEW

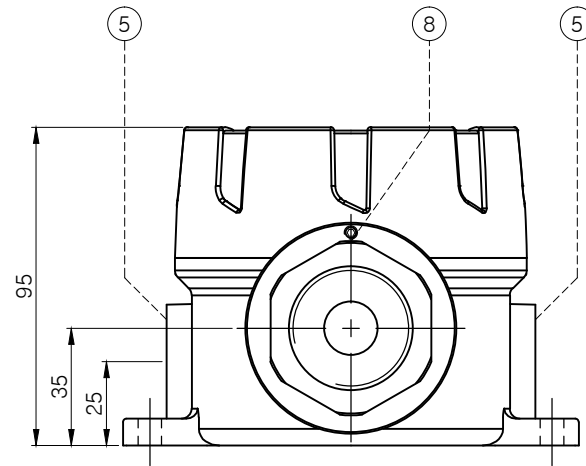

BOTTOM VIEW

BILL OF MATERIAL				
NO	DESCRIPTION	MAT'L	Q'TY	REM'K
1	MAIN BODY	ALDC	1	TEFLON COATING
2	HOUSING COVER	ALDC	1	TEFLON COATING
3	SENSOR HEAD	STS316	1	
4	GND HOLE		1	5 mm
5	CABLE INLET		2	3/4"PF
6	MOUNT HOLE		2	7 mm
7	MODEL NAME PLATE	P.C	1	
8	LENCH BOLE	STS316	1	4 mm
9				
10				
11				
12				
13				
14				
15				

GENERAL NOTES

- MODEL: GTD-1000Tx
- FUNCTION: TRANSMITTER TYPE
- TYPE: DIFFUSION TYPE
- ENCLOSURE: Ex d IIC T6(KCs)
- DETECTABLE GAS : TOXIC GAS
- MEAS. METHOD: ELECTRO CHEMICAL CELL TYPE
- MEAS. RANGE: PPM
- MEAS. SIGNAL: 4-20mA,DC/FS
- RESPONSE TIME: 45 SEC/90% SCALE
- ZERO DRIFT: 3%-FS/YEAR
- OPERATION TEMP.: -20 TO 50 deg.C
- OPERATION HUMIDITY: 5 TO 99% RH
- OPERATION POWER: 18-31V.DC / 200mA MAX
- SIGNAL CABLE TYPE: CVWS & B 1.5SQ*3C
- CABLE CONNECTION LENGTH: MAX. 2500M

△					
△					
△					
△					
REV.	DESCRIPTION	DATE	REV'D	CHECKED	APP'D

GASTRON CO.,LTD.
(Manufacture/Ansan,Korea)

PROJ. NO	
ITEM NAME	GAS DETECTION & MONITORING SYSTEM
DRAWING NAME	LOCAL COMBUSTIBLE GAS DETECTOR (GTD-1000Tx) LAYOUT & DIMENSIONAL DWG.
PROJECT DOC. NO.	REV.