



Headquarters / Engineering research laboratory :
23 Gunpo Advanced Industry 1-ro(Bugok-dong), Gunpo-si, Gyeonggi-do
Tel +82-31-490-0800 Fax +82-31-490-0801

Yeongnam business office / Plant :
55 Gonghangap-gil 85beon-gil, Gangseogu, Busan Metropolitan City
Tel +51-973-8518 Fax +51-973-8519

E-mail : info@gastron.com

www.gastron.com

GTD-2000Ex

Instruction Manual



Read in detail for correct use.

Gas & Flame Detection System

GASTRON



When abnormalities occur after purchasing the product,
please contact the following address.

- Address : 23 Gunpo Advanced Industry 1-ro, Gunpo-si, Gyeonggi-do
- Tel : 031-490-0800
- Fax : 031-490-0801
- URL : www.gastron.com
- e-mail : info@gastron.com

We sincerely thank you for purchasing the product of Gastron Co. Ltd.

Our Gastron Co.Ltd. is a company specialized in Gas detector and Gas Monitoring System, being recognized by many consumers due to the best quality and use convenience. We always enable you consumers to find desired products nearby and are ceaselessly studying and striving for development of Gas detectors satisfying customers. From now on, solve all anguishes concerning Gas detector with the products of Gastron Co. Ltd, We Gastron Co. will take a responsibility and give you satisfaction.

In the present instruction manual, operation method for Gas detector as well as simple methods for maintenance and repair, etc. are recorded. If you read it in detail and keep it well, for reference when you have questions, then it will give you much help.

- For accurate operation of Gas detector, check up and calibrate for more than once in every 6 months.
(* See No. 13 of KOSHA GUIDE : P-135-2013 / 8.3 paragraph on qualification and calibration)
- For accurate operation of Gas detector, checkup and calibration with calibration gas before measurement is recommended.
- When not calibrated, it may cause malfunction of the equipment due to problems resulting from Sensor aging.
- When the present instrument should be dismantled, those with professional skills for Gas detector should conduct the operation.
- For power supply cable, wire specifications should be determined by referring to the item of "Length of installed cable".
- For the contents on checkup and calibration of Gas detector, please use our company's engineering department , e-mail, or web site.

The present product and the product manual can be changed without advance notice for performance improvement and use convenience of the product.

* KOSHA GUIDE : P-135/6-2018

Calibration should be executed periodically at periods required by the manufacturer

1. Overview	6		
2. Structure	6		
3. Specification	7		
3.1. Basic Specifications	7		
3.2. Mechanical Specifications	7		
3.3. Electrical Specifications (Standard Type)	8		
3.4. Environmental Specifications	8		
4. Name and description of each part	9		
4.1. Components	9		
5. Installation	11		
5.1. Separation of Housing Cover	11		
5.2. Configuration of Main PCB	12		
5.2.1. Wire connection method of driving method for 4~20mA Source	14		
5.2.2. Wire connection method of driving method for 4~20mA Sink	14		
5.2.3. Wire connection method of driving method for 4~20mA 3Wire Sink	15		
5.3. Length of installed cable	15		
6. Operation Flow for detector	17		
6.1. Initial operation state (Power On)	17		
6.2. Gas Measuring Mode	17		
6.3. Operation Flow	18		
6.4. Menu Configuration Table	19		
7. System Mode	20		
7.1. PROGRAM MODE	20		
7.2. CALIBRATION MODE	21		
7.2.1. Zero Calibration	21		
		7.2.2. Span Calibration	22
		7.3. ALARM Mode	23
		8. Troubleshooting	25
		8.1. Fault List	25
		8.2. Recovery List	25
		9. Outline drawing and Dimensions	26
		9.1. Standard Type	26
		9.2. Upon coupling of warning light	27
		9.3. Upon coupling of Raincover	28
		10. Notes before installation	29
		10.1. Selection of installation place(Data from occupational safety and health regulations)	29
		10.2. Selection of installation place(Data from safety management regulations for high-pressure gas)	29
		10.3. Notes upon installation	29
		11. Revision record	31

GTD-2000Ex flammable Gas detector has been developed to prevent accidents beforehand by detecting various leaked gases generated in industry fields such as plants producing or using flammable gas, gas storage place, manufacturing processes, etc.

GTD-2000Ex flammable Gas detector is installed in areas with a risk of gas leakage to display measured values with LCD, OLED installed in the detector by continuous detection of gas leakage, providing DC 4~20mA standard output. Also, DC 4~20mA standard output can connect up to the maximum of 2500m (upon using CVVS or CVVSB 1.5sq \uparrow Shield Cable) in transmission distance of output signals of detector and receiving unit.

The present GTD-2000Ex flammable Gas detector should be used at altitude of less than 1000M above sea level.

2. Structure

GTD-2000Ex body is made of aluminum alloy material in a structure of complete pressure-resistant explosion-proof type(Ex d IIC T6),with the gas sensor module being composed of stainless steel material. It can be installed in the areas with a risk of leakage and explosion of all flammable gases, displaying leakage situation of gas at the installed field by embedding LCD, OLED in the detection unit. Inside structure is comprised of display unit displaying measured values, terminal unit for outputting measured values (DC4- 20mA) to outside and one PCB. Outside structure is comprised of detector unit for detection of gas leakage and Cable lead-in unit. Maintenance and repair operations are convenient since calibration operation can be conducted outside of the Gas detector by using Magnet-bar outside of the detector unit body.

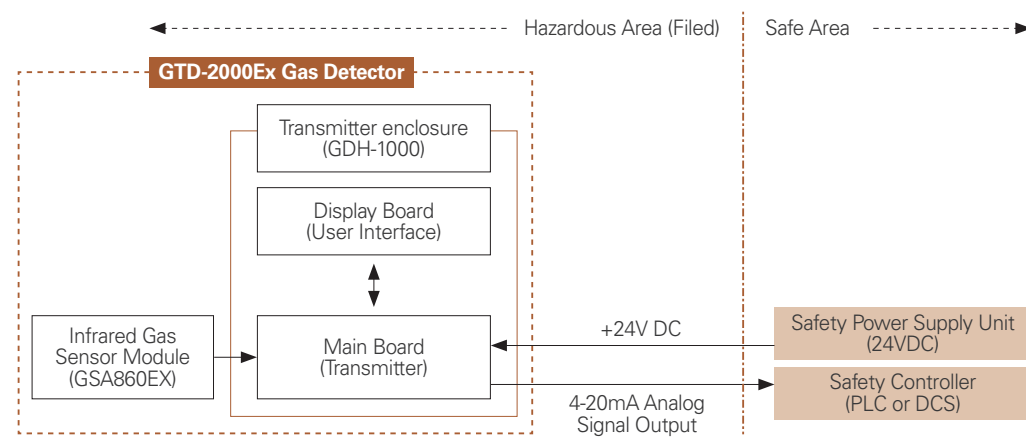

[Figure 1. GTD-2000Ex Overview]

3.1. Basic Specifications

ITEMS	SPECIFICATION	
Measuring Type	Diffusion type	
Measuring Value Display	Local Digital LCD or OLED Display	
Measuring Method	- Contact combustion type (Catalytic Cell) - Thermal conduction type (Thermal Conductivity Cell) - Hot wire-type semiconductor (Heated-semiconductor Cell)	
Detectible Gas	Flammable gas	
Measuring Range	0~100% LEL	
Accuracy	≤ ±3% / Full Range	
Zero Drift	≤ 2% / Full Range	
Response Time	90% of full Scale in less than 15 sec	
Certification (Approvals Classification)	KCs: Ex d IIC T6,T5,T4, IP65 ATEX/IECEX: II 2 G Ex d IIC Gb T4~T6 SIL2, MED, ABS, DNV	
Basic Interface	Analog 4-20mA current interface	
HART Interface	HART REV7 (Option)	
Option	HART Board	
	GTL-100 warning light	
	Rain Cover	
Warranty	Body (Transmitter)	2Year
	Sensor	1Year

3.2. Mechanical Specifications

ITEMS	SPECIFICATION	
Explosion Proof type	Pressure-resistant explosion-proof enclosure	
Dimension	136(W) × 166(H) × 110 (D) mm	
Weight including Sensor	App. 1.5kg	
Mounting type	Wall mount	
Mounting Holes	∅ 7 ±0.1	
Cable inlet	3/4" PF (1/2" or 3/4" NPT)	
Body material	Body (Transmitter)	aluminum alloy
	Sensor	Stainless Steel (STS316)

3.3. Electrical Specifications (Standard Type)

ITEMS	SPECIFICATION	
Input Voltage(Standard) ※ Customer supplied PSU must meet requirements IEC1010-1 and CE Marking requirements.	Absolute min: Nominal: Absolute max: Ripple maximum allowed:	18V 24V 31V 1V pk-pk
Wattage	Max. wattage: Max. current:	4.8W @+24 VDC 200mA @+24 VDC
Analog output Current	0-20mA(500 ohms max load) All readings ± 0.2mA Measured-value signal: 4mA(Zero) to 20mA(Full Scale)	
	Fault: 0-100% LEL: 100-109%LEL: Over 110% LEL: Maintenance:	0mA 4mA - 20mA 20mA - 21.4 mA 22mA 3mA
Analog output current ripple & noise max	±20uA	
Wiring requirement	Power	CVVS or CVVSB with shield
	Analog	CVVS or CVVSB with shield
Signal transmission distance (Cable Connection Length)	Analog	2500m
EMC Protection:	Complies with EN50270	

3.4. Environmental Specifications

ITEMS	SPECIFICATION	
Operation Temperature	Body	-40 to 80 °C
	Sensor	See sensor specifications
Storage Temperature	Body	-40 to 80 °C
	Sensor	See sensor specifications
Operation Humidity	Body	5 to 99% RH (Non-condensing)
	Sensor	See sensor specifications
Pressure Range	90 to 110KPa	
Max. air velocity	6m/s	

4.1. Components

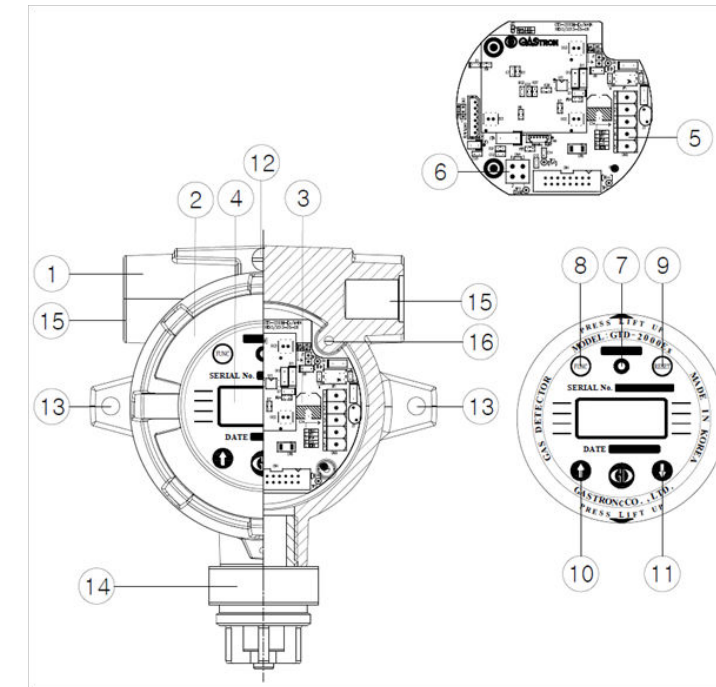

[Figure 2. Components of GTD-2000Ex]

NO	NAME	DESCRIPTIONS
1	Housing Body	Protect PCB Board embedded inside sensor and housing from environment change and impact of outside.
2	Housing Cover	Assembled to Detector Housing Body, with Top face made of circular glass, allowing the values displayed in LCD to be viewed.
3	Main PCB	Amplify minute outputs produced from Sensor Element and convert the as standard output of 4-20mA.DC, and transmit Data to Display unit.
4	Display PCB	Display Data(measured values) sent from Main /Terminal(Transmitter) PCB in LCD, and display power supply state by Power Lamp
5	Power/Signal Terminal	CN8 is configured with power supply of DC 24V and Connection terminal for standard output of DC 4~20mA (VISO, +24V, mA, GND, ETH)
6	Sensor Terminal	CN4 is the Sensor Connection Terminal.
7	Power LED	Lamp always turned ON when power is supplied
8	Function Key	Used when having the function setting mode entered into by using Magnet-Bar for contact of more than 2sec in gas measuring mode, or when the data changed in function setting mode is saved.

NO	NAME	DESCRIPTIONS
9	Reset Key	Converted when cancelled during parameter setting or touched for more than once by using Magnet bar to return to the previous state. (Converted to the previous mode by one stage at a time upon every touch.
10	↑(UP) Key	Converted or transformed by one stage at a time when touched once by using Magnet-bar upon mode conversion or figure transformation (transformed to the higher stage)
11	↓(DOWN) Key	Converted or transformed by one stage at a time when touched once by using Magnet-bar upon mode conversion or figure transformation(transformed to the lower stage)
12	External Earth Ground	- Outside grounding for protection from outside noise or strong electric field - For grounding cable, use conductor larger than 4mm upon coupling connection
13	Mount Hole	Hole to mount Gas Detector onto outer wall and other installation place.
14	Sensor	Place for detection of actual gas leakage where the amounts of leaked gas are converted to electric signals for transmission to Main PCB
15	Conduit Connection	Provided for supply of power to detection unit and lead-in of the cable for measured output signals upon installation operation, with 3/4", 1/2" PF or NPT being prepared for Cable lead-in unit
16	Internal Ground	- Inside of Detector should be grounded for protection from noise or strong electric field of outside - Use a conductor of larger than upon coupling and connection of grounding wire.

[Table 1. Description on components of GTD-2000Ex]

Absolutely no one other the approved users or those of the headquarters in charge of installation and repair should be allowed to install in the field, open or operate Cover of the installed gas leakage detector. Otherwise serious damages to life and property may be inflicted. Also, make sure to shut off the power supply and conduct operation after checking whether explosive GAS remains or flammable substances are present in the surroundings

5.1. Separation of Housing Cover

- <Warning - Do not open during current application.>
- Cover can be separated when the cover for gas leakage detector is turned counterclockwise after slotted set screw for fixing of body's cover (M4 x 1ea) is turned 3~4 turns clockwise by using a hexagonal wrench (M2). When Cover is separated, LCD unit is displayed.

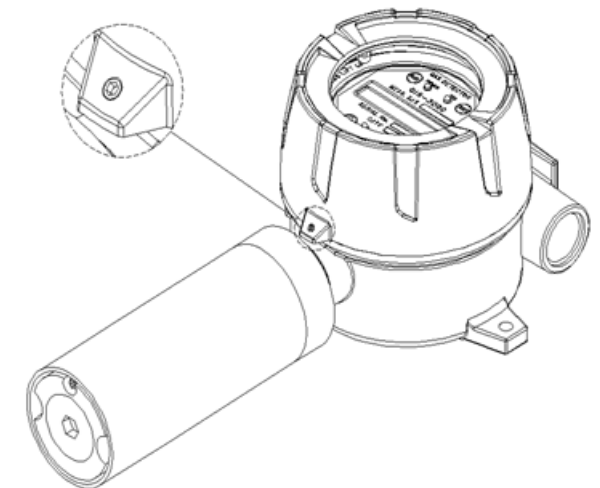

[Figure 3. Slotted set screw]

- When Cover is separated, separate Display Parts in the following order.
 - ① Simultaneously push inward the fixing chains on left side and right side on the front face of LCD unit.
 - ② Separate from Gas detector body by pulling Display Parts forward in the pushed state.
 - ③ Main PCB is installed below Detector Body after separation of Display Parts.

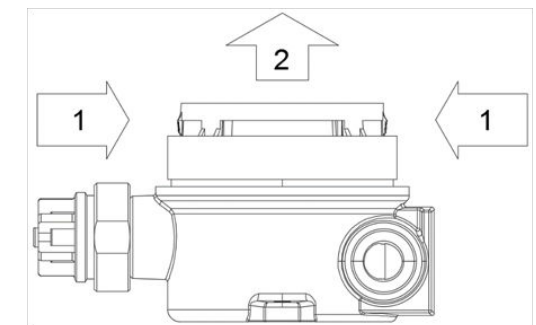

[Figure 4. Separation method for Display Part]

5.2. Configuration of Main PCB

- When Display Parts are separated, the layout diagram for Main PCB terminals as follows can be seen

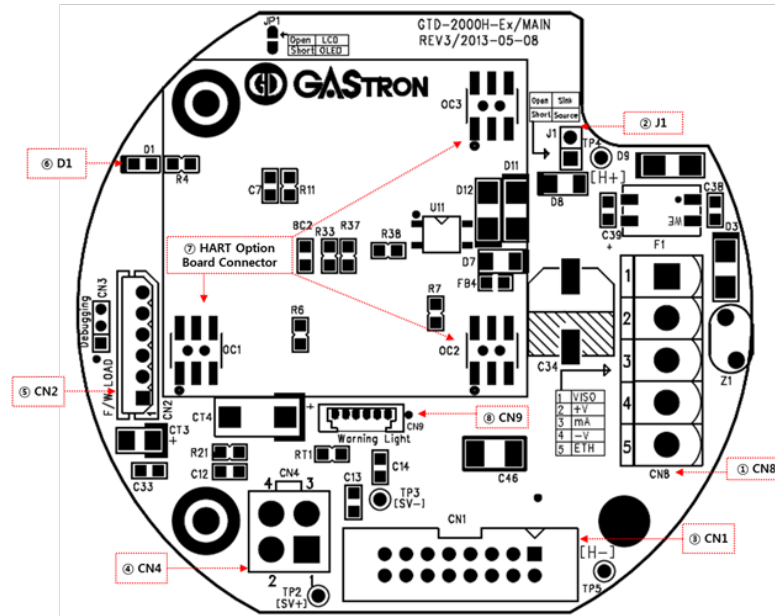

[Figure 5. Layout diagram for Main PCB terminals]

No	NAME	DESCRIPTION
1	CN8	Power & Output Signal Terminal
2	J1	4~20mA Source / Sink selection jumper (ON: Source Type, OFF: Sink Type)
3	CN1	Display LCD Connector
4	CN4	Sensor Connector
5	CN2	Program download Connector
6	D1	Status LED (Blinks by the unit of 1 sec in the case of normal operation)
7	OC1, OC2, OC3	HART Option Board Connector
8	CN9	Warning light (GTL-100) Interface Connector

[Table 2. Description on main parts of Main PCB]

- HART Option board can be mounted by using OC1, OC2, OC3 of the above layout diagram, and is mounted by using 3Ø Screw hole on the top left side of HART Option board.
- Configuration of terminal
- When Display Parts are separated, Terminal Block in Main PCB can be seen as shown in the following figure, which is separated from Main PCB when held by hand and pulled up.
- <Warning - Conduct operation after shutting off the power supply upon connection of power supply terminal.>
- Loosen by turning counterclockwise the terminal-fixing screws at 5 places in the upper part of the separated Terminal Block CN12 (VISO, +V, mA, -V, ETH) Connector by using Ø driver, connect DC18-31V power supply to +, -, and Signal Cable to mA, followed by locking terminal-fixing screws at 5 places clockwise to prevent terminal from breaking away, and fit it in Main PCB as before separation

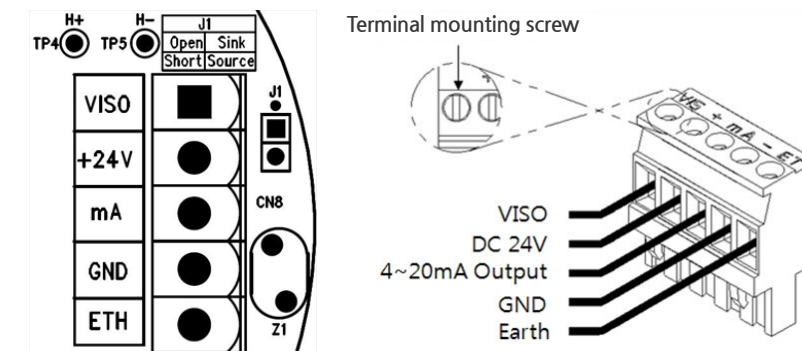

[Figure 6. Configuration of CN8 terminal]

NO	PCB SILK	PIN NAME	DESCRIPTION	
			4~20mA Source Drive (J1 Jumper ON)	4~20mA Sink Drive (J1 Jumper OFF)
1	VISO	VIS	N.C	4~20mA Sink In(+)
2	+24V	+	+24V / POWER (+)	
3	mA	mA	4~20mA Source Out	4~20mA Sink Out(-)
4	GND	-	GND / POWER (-)	
5	ETH	ET	EARTH	

[Table 3. Detailed description on CN8 terminal]

- Upon configuring the Terminal, use CVVS or CVWSB 2.0sq] Shield Cable.
- To connect 4Pin Terminal of the existing old-style GTD2000Ex, fasten the terminal based on +24V as No.2 plate.

5.2.1. Wire connection diagram of driving method for 4~20mA Source

- Connect 4-20mA Signal terminal on PLC side to 'mA' of GTD-2000Ex, while GND terminal is used in common with the power supply. And then turn the J1 Jumper ON.
- HART Communicator can be used only in the model using HART Option board

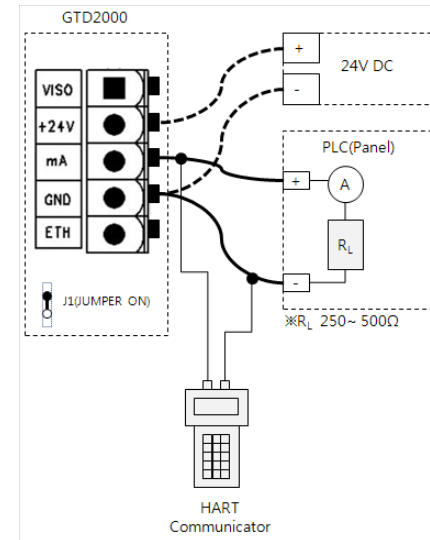

[Figure 7. Configuration of 4-20mA Source]

5.2.2. Wire connection diagram of driving method for 4~20mA Sink

- Connect 4-20mA Sink output (+) terminal on PLC side to VISO terminal, and (-) terminal to 'mA' terminal. And then turn the J1 Jumper OFF.
- HART Communicator can be used only in the model using HART Option board.

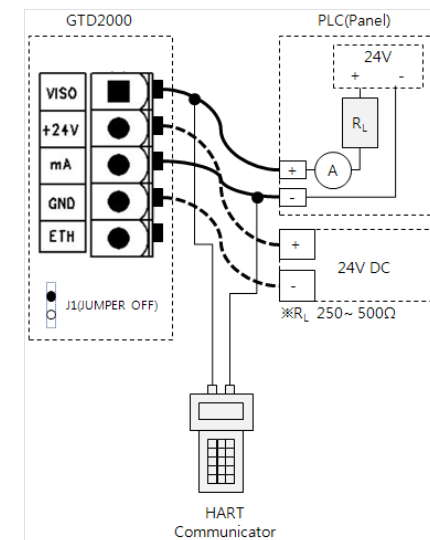

[Figure 8. Configuration of 4-20mA Sink]

5.2.3. Wire configuration diagram of driving method for 4~20mA 3Wire Sink

- Connect 4-20mA Sink output (+) terminal on PLC side to VISO terminal, and (-) terminal to (24V DC) (-) terminal. Connect 'mA' terminal of GTD-2000Ex to 'GND' terminal. Then connect turn the J1 Jumper OFF.

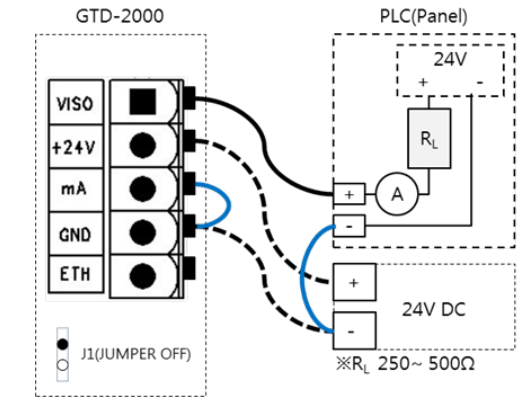

[Figure 9. Configuration of 4-20mA 3Wire Sink]

5.3. Length of installed cable

- The maximum length between GTD-200Ex and power supply is determined by the wire specifications.
- Maximum installation length = $V_{MAXDROP} \div I_{MAX} \div WIRER/m \div 2$
 - $V_{MAXDROP}$: Maximum Power Loop Voltage Drop (=Power Supply voltage - min operating voltage)
 - I_{MAX} : Maximum current value of GTD-2000Ex
 - $WIRER/m$: The resistance of the wire (ohms/meter value available in wire manufacturer's specification data sheet)
- An example for installation length using 24V power supply and 16AWG is as follows.
 - GTD-2000Ex minimum operating voltage = 18 Vdc
 - $V_{MAXDROP} = 24 - 18 = 6V$
 - $I_{MAX} = 0.2A (200mA)$
 - $6 \div 0.2 \div 0.01318 \div 2 = 2276m \approx 2.000m$

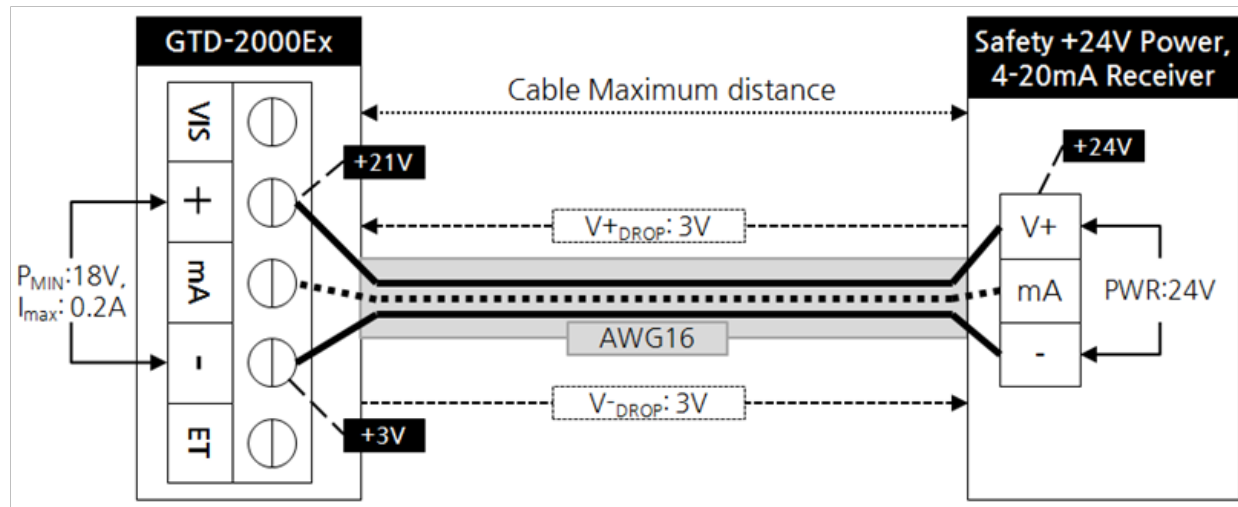

[Figure 10. Length calculation of installed cable for GTD-2000Ex]

■ Installation length of power supply cable according to cable classification is as shown in the following table.

AWG	mm ²	COPPER RESISTANCE(ohms/m)	METERS
12	3.31	0.00521	2879
14	2.08	0.00828	1811
16	1.31	0.01318	1138
18	0.82	0.02095	715
20	0.518	0.0333	450

[Table 4. Installation length of power supply cable for GTD-2000Ex]

6.1. Initial operation state (Power On)

■ When power is supplied to the power supply terminal on MAIN PCB board after wiring, the following contents can be confirmed in the LCD unit, a stabilization time of about 30 minutes is required after initial supply of operation power, and normal operation occurs from the time of sufficient stabilization.

GTD-2000 [V X.XX]	- When power supply is turned ON, model name and product firmware version are displayed in LCD(OLED).
SELF TEST [>>>0179]	- SELF TEST is executed for 3min, and '>' character in the 2nd row informs progress state

6.2. Gas Measuring Mode

■ When there is no abnormality in SELF TEST after power is turned ON, the following state of gas measurement is automatically entered into.

[%LEL] [0.0]	- Operated as follows when it is in Normal state. - In the 1st row, measured GAS NAME and measuring GAS unit are alternately displayed by the unit of 1sec, while the current measured value is displayed in the 2nd row.
[COMB.] [0.0]	- When Magnet-bar is in contact with 'Func' key for more than 2 sec in the current screen, it is changed to the setting Mode. ※ '*' character is displayed in the left part of the 1st row during HART communication ※ When ENG. Mode is turned ON, '<' character is displayed in the left part of the 2nd row
[%LEL] [30]	- When the 1st or the 2nd Alarm occurs, it is operated as follows..(It is operated when ALARM USED item of ALARM Mode is turned ON) - In the 1st row, it is operated in the same way as in Normal state, while ALARM message and gas measured value are alternately displayed in the 2nd row by the unit of 1 sec.
[%LEL] [ALARM1]	- When explosion-proof warning light of GTL100 is installed, red LED and Buzzer are operated by blinking by the unit of 1 sec upon occurrence of the 1st Alarm, while they continue to be operated without blinking upon occurrence of the 2nd Alarm. - If Latch is turned on during Alarm function, Alarm continues to be operated when not cleared by using Reset.
[%LEL] [OVER]	- When the gas measurement value is inputted as larger than 10%. The text of "OVER" is displayed by the unit of 1 second, and 4~20mA is operated as 22mA.
[%LEL] [UNDER]	- When the gas measurement value is inputted as less than-10%. The text of "UNDER" is displayed by the unit of 1 second, and 4~20mA is operated as 2mA. ※ The relevant function operates when UNDER function is turned ON.
[FAULT1] SEN EMPT	- When there is abnormality in the device, Fault No. and message are outputted. - At this time, 4~20mA is operated as less than 2mA. - Mode displayed when Fault No.1 sensor on left side is not mounted.

6.3. Operation Flow

- After Power is turned On, undergo the self diagnosis process and enter in the measuring mode. At this time entering inside system mode is possible through the front face key operation.
- Timeout between Level1 and Level2의 Timeout is 10 seconds, while it is configured as 1 hour in calibration of and Test Mode.
- When "RESET" key is touched in program Mode screen, it is returned to measuring state, while it is returned to the upper stage when "RESET" key is touched in each program setting screen.

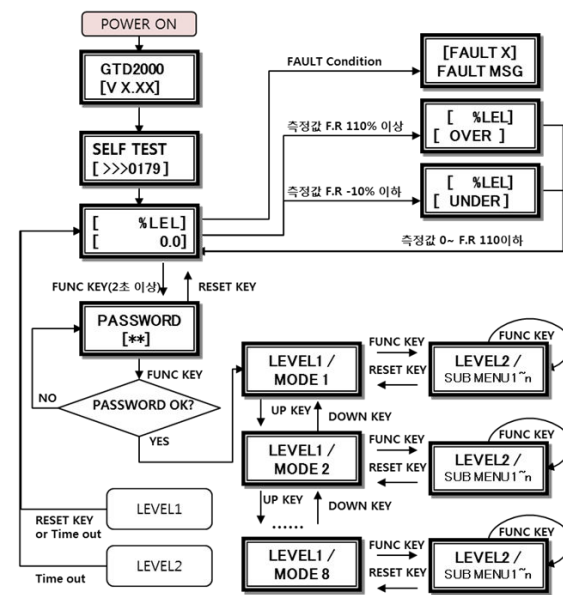

[Figure 11. Mode configuration of GTD-2000Ex]

- Operation key for control of sensor system mode is defined as follows.

ITEM	NAME	DESCRIPTION
FUNC	Function key	Entry function for sensor Mode setting (Input with Magnet-bar for more than 2 seconds in the measuring mode) . Entry function for the next stage ofLevel2 and saving function for setting values
RESET	Reset key	Move to the stage before the entered LEVEL
↑	Up key	Change the setting value Plus for the next stage mode configured in LEVEL1 and Level2
↓	Down key	Entry function for sensor Mode setting (Input with Magnet-bar for more than 2 seconds in the measuring mode) . Entry function for the next stage ofLevel2 and saving function for setting value

6.4. Menu Configuration Table

LEVEL1	LEVEL2		DEFAULT
	NAME	PARAMETER	
PROGRAM MODE	GAS TYPE (Gas Type)	[DEFIN./USER]	DEFIN.
	GAS SEL(Gas Select)	Select embedded gas name	COMB.
	UNIT SEL (Unit Select)	%/%LEL/PPM/PPB	%LEL
	D-POINT(Decimal Point)	0.100/1.00/10.0/100	100
	HIGH SCL (High Scale)	1~10000	100
	PASSWORD	00~99	00
CALIBRA. MODE (Calibration Mode)	CALIBRA. [ZERO] (Calibration Zero)	ZERO CAL [NO,YES]	[NO]
		ZERO GAS [0]	
		ZERO >>>> [SUCCESS / FAIL]	
	CALIBRA. [SPAN] (Calibration Span)	CAL. DATA [0/ FAIL]	
		SPAN CAL [NO, YES]	[NO]
		SPAN GAS [0]	
ALARM MODE	ALM USED (Alarm Used)	[OFF / ON]	OFF
	AL LATCH (Alarm Latch)	[OFF / ON]	OFF
	A1 LEVEL (Alarm-1 Level)	[1 ~ 9999]	20
	A1 TYPE (Alarm-1 Type)	[INC / DEC]	INC
	A1 DBAND (Alarm-1 Dead Band)	[0.0 ~ 10.0%F.S]	0
	A1 TIME (Alarm-1 Time)	[0~ 60]SEC	1
	A2 LEVEL (Alarm-2 Level)	[1 ~ 9999]	40
	A2 TYPE (Alarm-2 Type)	[INC / DEC]	INC
	A2 DBAND (Alarm-2 Dead Band)	[0.0 ~ 10.0%F.S]	0
	A2 TIME (Alarm-2 Time)	[0~ 60]SEC	1
SENSOR MODE	Factory Setting		
MAINTEN.MODE	Factory Setting		
DEVICE MODE	Factory Setting		
VERSION MODE	Factory Setting		
TEST MODE	Factory Setting		

7.1. PROGRAM MODE

PASSWORD [**]	- When "FUNC" key is touched for more than 2 sec by using Magnet-bar in measuring state, Password mode is entered into. - Touch " FUNC" key after setting Password by using "↑"key or "↓" key .
PROGRAM MODE	- If Password is accurate, Program item is entered into. - Mode is changed according to predetermined order whenever "↑"key or "↓"key is touched. (PROGRAM -> CALIABRA. -> ALARM -> SENSOR -> MAINTEN. ->DEVICE -> VERSION -> TEST)
GAS TYPE [DEFIN.]	- As a mode for setting type of Gas name, Gas Type is changed whenever "↑"key or "↓"key is touched. (DEFIN. / USER) - DEFIN. Is an acronym for Define, and selected when the gas name set inside is used, while USER is used for personal determination of the gas name by the user. - If "FUNC" is touched when the desired Gas Type is displayed, Gas name is set and the next Program item is entered into.
GAS SEL [COMB.]	- As a mode for setting of Gas name, Gas name is changed whenever "↑"key or "↓"key is touched. - When Gas Type is set by DEFIN., gas name can be selected for use, while 5 characters are set for use by the user when set as USER. Available characters are figure, alphabet capital letter, space, dot, and a cursor in black box form as shown in the left-side box is displayed when the position is moved to the set character.
USER GAS [■]	
UNIT SEL [%LEL]	- As a mode for setting of Gas measuring unit, Gas measuring unit is changed whenever "↑"key or "↓"key is touched. (% / %LEL / PPM / PPB). - If "FUNC" key is touched when the desired Gas measuring unit is displayed, and the next Program item is entered into.
D-POINT [100]	- As a mode for setting of decimal point, the position of decimal point is changed whenever "↑"key or "↓"key is touched.(0.100/1.00/10.0/100) - If "FUNC" key is touched when the desired position of decimal point is desired, the position of decimal point is set and the next Program item is entered into.
HIGH SCL [100]	- Mode for setting High scale value to be displayed at the time of Full Range with the scale value being increased or decreased whenever "↑"key or "↓" key is touched (1 ~ 10000) - If "FUNC" key is touched when the desired High scale is displayed, the value of High scale is set and the next Program item is entered into.
PASSWORD [00]	- Mode for setting Password , which is checked upon entering in the Program Mode. - If "FUNC" key is touched after setting by using "↑" key or "↓" key , the password is set and the next Program item is entered into.

7.2. CALIBRATION MODE

- Due the characteristics of Gas detector, a stabilization time of at least about 30 minutes is required after supply of power, and the management criteria may be varied with field conditions.

7.2.1. Zero Calibration

PASSWORD [**]	- When "FUNC" key is touched for more than 2sec by using Magnet-bar in measuring state, Password mode is entered into. - Touch " FUNC" key after setting Password by using "↑" key or "↓" key.
CALIBRA. MODE	- Select "CALIBRA. MODE" by touching "↑"key or "↓"key . - If "FUNC" is touched when "CALIBRA. MODE" is displayed, Calibration Mode is entered into. - When "RESET" key is touched, the measuring state is returned to.
CALIBRA. [ZERO]	- If "FUNC" key is contacted when "CALIBRATION MODE" item is displayed, Zero Calibration item is selected. - If "FUNC" key is touched when it is [ZERO] by touching "↑" key or "↓" key, Zero Calibration mode is entered into.
ZERO CAL [NO]	- Zero Calibration is executed if FUNC key is touched when it is [YES] by touching "↑"key or "↓"key.
ZERO GAS [0]	- Zero calibration is automatically executed if FUNC key is touched when the measured value is stabilized after clean air or 100% nitrogen as the gas is injected in the detector unit at the flow rate of 500mL/min for about 1 minute by using a calibration apparatus .
ZERO >> [SUCESS]	- When Zero calibration is successful, "ZERO SUCCESS" is displayed in LCD Display for 2 seconds, and then converted to CALIBRATION DATA Mode.
ZERO >> [FAIL]	- When Zero Calibration is not successful, "ZEROFAIL" is displayed for 2 seconds, and then converted to CALIBRATION DATA Mode. - ZERO FAIL occurs when the sensor input value exceeded by more than 70% of the total ADC input range.
CAL.DATA [0]	- Function for checking whether calibration was normal after execution of calibration as a Mode for displaying measured values after calibration, - Display FAIL Text and the current measured value at an interval of 1sec in the case of FAIL. - When "RESET" key is touched, "CALIBRATION MODE" is returned to.

7.2.2. Span Calibration

CALIBRA. MODE	<ul style="list-style-type: none"> - Select "CALIBRA. MODE" by touching "↑" key or "↓" key . - If "FUNC" key is touched when "CALIBRA. MODE" is displayed, Calibration Mode is entered into. - When "RESET" key is touched, the measuring state is returned to.
CALIBRA. [SPAN]	<ul style="list-style-type: none"> - If "FUNC" key is touched when it is [SPAN] by touching "↑" key or "↓" key , Span Calibration mode is entered into.
SPAN CAL [NO]	<ul style="list-style-type: none"> - If "FUNC" key is touched when it is [YES] by touching "↑" key or "↓" key, Span Calibration is executed.
SPAN GAS [50]	<ul style="list-style-type: none"> - If "FUNC" key is touched when the measured value is stabilized after injection of standard gas in sensor unit for about 90sec at a flow rate of 500mL/min by using the calibration apparatus, the next mode is entered into.
[50] [50]	<ul style="list-style-type: none"> - When Hold function of Maintenance Mode is turned ON , the current maximum value of SPAN gas is Held, and the held value is displayed in the 1st row. - The current measured value is displayed in the 2nd row.
SPAN SET [50]	<ul style="list-style-type: none"> - As a Mode for setting of standard gas value, the value is set by touching "↑" key or "↓" key when there is no Fail message. - Fail message is displayed when the value of injected standard gas is not normal, with the Fail message being as follows. Fail message and Span set values is displayed alternately.
SPAN SET LOW FAIL	<ul style="list-style-type: none"> ① "LOW FAIL" occurs when the difference between injected Gas value and ZERO calibration value is less than 1%
SPAN SET HIGH FAIL	<ul style="list-style-type: none"> ② "HIGH FAIL" occurs when the value of injected Gas is more than 95% of total ADC input range. - "RNG FAIL" occurs when the value of injected Gas operates as the currently set SPAN value, exceeds the input range of ADC by more than 95%. When the SPAN value is controlled, the relevant message is automatically cleared in the case of normal state
SPAN >> [SUCESS]	<ul style="list-style-type: none"> - If "FUNC" key is touched after completion of setting for standard gas value, Span Calibration is automatically executed. If successful, "SPAN SUCESS" is displayed for 2sec in LCD Display, and then converted to "CAL DATA" Mode.
SPAN >> [FAIL]	<ul style="list-style-type: none"> - If Span Calibration is not successful, "SPAN FAIL" is displayed for 2sec, and then converted to "CAL DATA" Mode.
CAL.DATA [0]	<ul style="list-style-type: none"> - Mode for displaying measured values after calibration, as a function for checking whether calibration was normal after execution of calibration. - When "RESET" key is touched, "CALIBRATION MODE" is returned to.

7.3. ALARM MODE

PASSWORD [**]	<ul style="list-style-type: none"> - When "FUNC" key is touched for more than 2sec in measuring state, Password mode is entered into. - Touch " FUNC" key after setting of Password by using "↑" key or "↓" key.
ALARM MODE	<ul style="list-style-type: none"> - Select "ALARM MODE" by touching "↑" key or "↓" key . - If "FUNC" key is touched when "ALARM MODE" mode is displayed, Alarm setting item is entered into. - When "RESET" key is touched, the measuring state is returned to.
ALM USED [ON]	<ul style="list-style-type: none"> - Item for turning the Alarm mode setting ON/OFF. - ON/OFF state is changed by touching "↑" key or "↓" key, where Alarm function and Alarm Mode can be set in the case of ON. - GTL100 explosion-proof warning light can be used only when set for ON . - When "FUNC" key is touched, the next mode is entered into.
AL LATCH [ON]	<ul style="list-style-type: none"> - Mode for setting of Reset method after Alarm1 operation where change occurs to "ON" and "OFF" whenever "↑" key or "↓" key is touched. - "OFF" setting is for the function of automatic resetting of Alarm, while "ON" setting is for the function of resetting only when the Reset key is pushed. - If "FUNC" key is pushed when the desired mode is displayed, the mode is set and the next Alarm setting mode is entered into.
A1 LEVEL [20]	<ul style="list-style-type: none"> - Mode for setting of Alarm1 level1, where the Alarm1 level is increased or decreased whenever "↑" key or "↓" key is touched. - If "FUNC" is touched when the desired Alarm1 value is displayed, the Alarm1 value is set, and the next item is entered into.
A1 TYPE [INC]	<ul style="list-style-type: none"> - Mode for setting of operation direction of Alarm1, where "INC" or "DEC" is displayed whenever "↑" key or "↓" key is touched. - "INC" Mode is the Mode setting of operating when it is larger than or the same as Alarm setting value, while "DEC" Mode is the mode operating when it is smaller than or the same as Alarm setting value.
A1 TYPE [DEC]	<ul style="list-style-type: none"> - If "FUNC" key is touched when the desired Mode is displayed, the Mode is set and the next item is entered into.
A1 DBAND [0]%F	<ul style="list-style-type: none"> - Mode for setting of Dead band value for operation of Alarm1 where the value is set by using "↑" key or "↓" key . - Function where Alarm1 operates at a value more than Alarm1 level plus Dead band value, and where Alarm1 is cleared at a value less than Alarm1 level minus Dead band value. - If "FUNC" key is touched when the desired Dead band value is displayed, the Alarm1 value is set and the next item is entered into.

A1 TIME 0 SEC	<ul style="list-style-type: none"> - Function to prevent occurrence of instantaneous malfunction of Alarm1 due the effects of outside impact and noise rather than normal operation, where the range for time setting can be set within 0~60sec. - For setting of Alarm1 delay time, "Alarm1 delay time is increased or decreased by the unit of Sec whenever "↑" key or "↓" key is pushed. - If "FUNC" key is pushed when the desired Alarm1 delay time is displayed, the Alarm1 delay time is set and the next item is entered into. - Ex) Alarm setting value: In the case of 20% LEL / Delay time: 5 Sec, alarm occurs when the measured value exists at more than the alarm setting value for more than 5sec based on 20%LEL, while the alarm does not occurs when it is lowered below the alarm setting value within 5 Sec.
A2 LEVEL [20]	<ul style="list-style-type: none"> - Mode for setting of Alarm2 level, where Alarm2 level is increased or decreased whenever "↑" key or "↓" key is touched . - "If "FUNC" key is touched when the desired Alarm2 value is displayed, the Alarm2 value is set and the next item is entered into.
A2 TYPE [INC]	<ul style="list-style-type: none"> - As a mode for setting of operation direction of Alarm2, "INC" or "DEC" is displayed whenever "↑" key or "↓" key is touched. - "INC" Mode is the mode operating when it is larger than or the same as the Alarm setting value, while "DEC" Mode is the mode operating when it is smaller than or the same as the Alarm setting value.
A2 TYPE [DEC]	<ul style="list-style-type: none"> - If "FUNC" key is touched when the desired mode is displayed, the mode is set and the next item is entered into .
A2 DBAND [0]%F	<ul style="list-style-type: none"> - Mode for setting of Dead band value for operation of Alarm2, where the value is set by using "↑" key or "↓" key. - Mode where Alrm2 operates at a value of more than Alarm2 level plus Dead band value, while Alarm2 is cleared at a value of less than Alarm2 level minus Dead band value . - If "FUNC" key is touched when the desired Dead band value is displayed, the Alarm2 value is set and the next item is entered into.
A2 TIME 0 SEC	<ul style="list-style-type: none"> - Function to prevent occurrence of instantaneous malfunction of Alarm2 due to the effects of outside impact and noise rather than normal operation, where the range of time setting can be set within 0~60sec. - For setting of Alarm2 delay time, "Alarm2 delay time is increased or decreased by the unit of Sec whenever "↑" key or "↓" key is pushed.. - If "FUNC" key is pushed when the desire Alarm2 delay time is displayed, the Alarm2 delay time is set and Alarm Mode is returned to. - Ex) Alarm setting value: In the case of 40% LEL / Delay time: 5 Sec, alarm occurs when the measured value exists at more than the alarm setting value for more than 5sec based on 40%LEL, while the alarm does not occur when it is lowered below the alarm setting value within 5 Sec.

8.1. Fault List

FAULT MESSAGE	DESCRIPTION & CONDITION	CAUSE FOR OCCURRENCE
FAULT1 "SEN EMPT"	Occurs when Sensor module is not connected	Defective connection of sensor module
FAULT2 "SEN HIGH"	Output value of sensor is outputted as more than the maximum value of ADC	Defective sensor module or defective ADC for Transmitter board
FAULT3 "SEN LOW"	Output value of sensor is outputted as less than the minimum value of ADC	Defective sensor module or defective ADC for Transmitter board
FAULT4 "EROM ERR"	Defective Transmitter EEPROM Checksum	Defective EEPROM for transmitter board
FAULT5 "+24V LOW"	Occurs when the main input power supply of 24V is inputted as less than 17V	Input power supply less than 17V or defective ADC for Transmitter
FAULT6 "ADC FAIL"	Defective Transmitter ADC	Defective ADC for transmitter
FAULT7 "H/W REV"	Error in H/W version	Defective MPU inside transmitter
FAULT8 "SEN HUNT"	When hunting error in gas measured value occurs repetitively	Defective output state of Sensor or noise for input power supply confirmed

[Table 5. Fault List]

8.2. Recovery List

No	CAUSE FOR OCCURRENCE	COPING MEASURE
1	Defective Sensor module	Replace Sensor
2	Defective ADC for Transmitter board	Replace Transmitter board
3	EEPROM for Transmitter board	1) Revise and recalibrate Parameter after enforcement of factory initialization 2) Replace Sensor Unit upon occurrence of the same phenomenon
4	Defective MPU inside Transmitter	Replace Transmitter Main Board
5	Defective output state of Sensor	Replace Sensor
6	Defective output state of Sensor	Replace Sensor
7	Noise for input power supply confirmed	Check noise state for noise of outside input voltage

[Table 6. Recovery List]

9.1. Standard Type

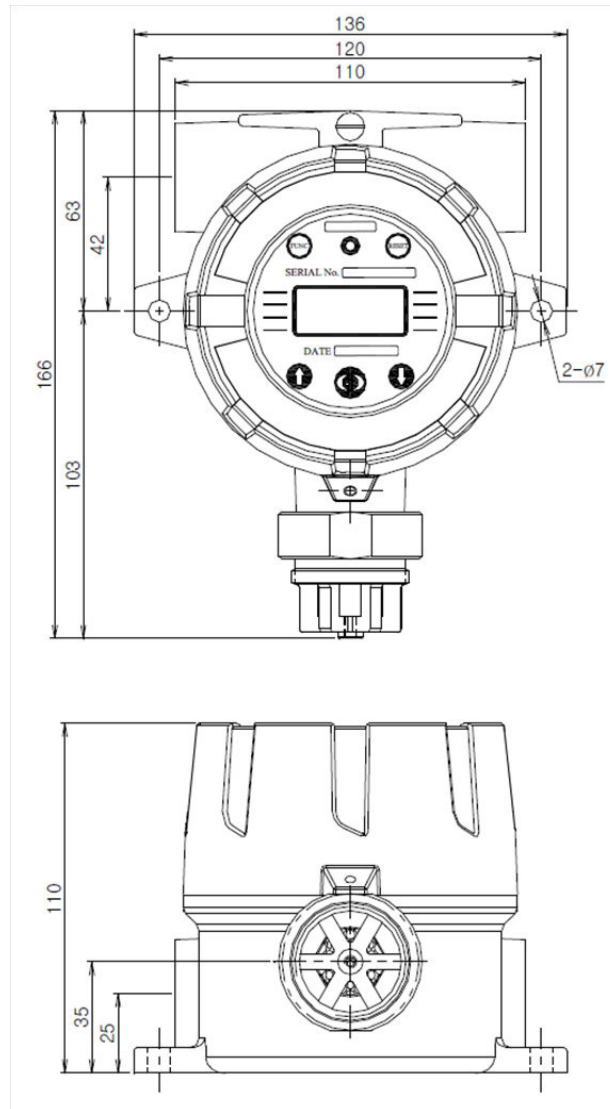

[Figure 12. Outline drawing for GTD-2000Ex Standard Type]

9.2. Upon coupling of warning light

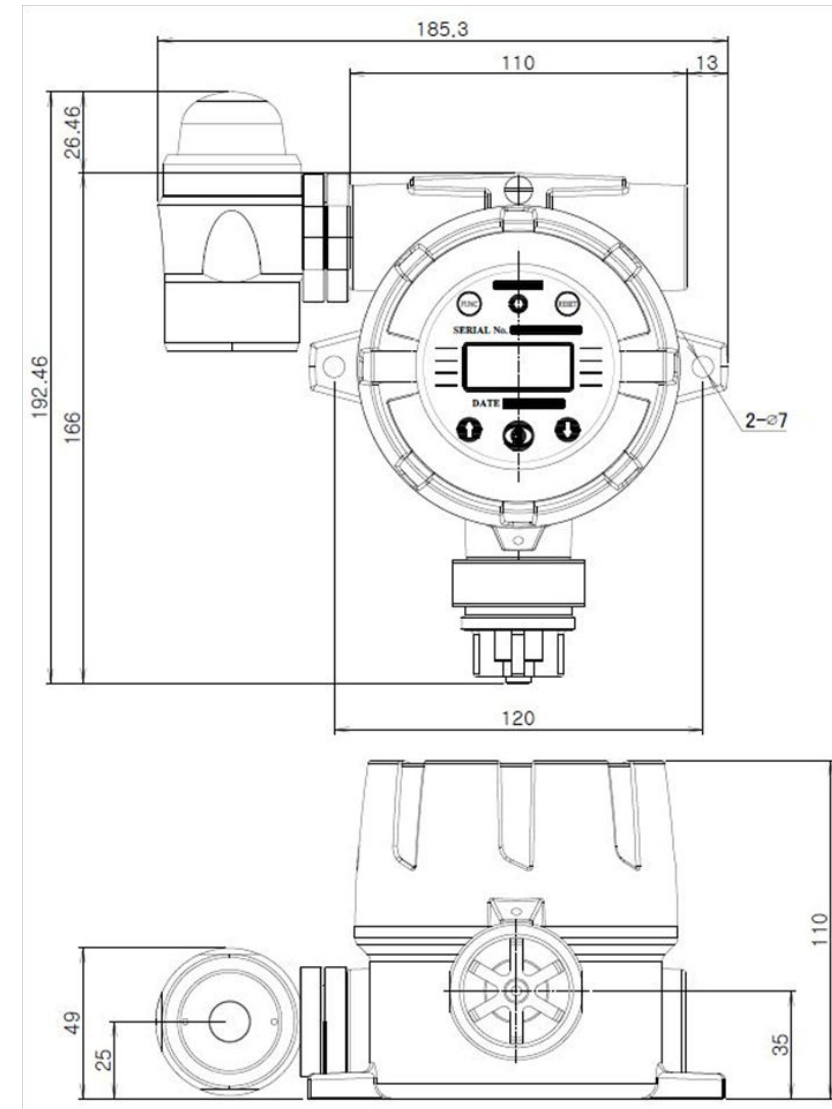

[Figure 13. Outline drawing for coupling of warning light for GTD-2000Ex]

9.3. Upon coupling of Raincover

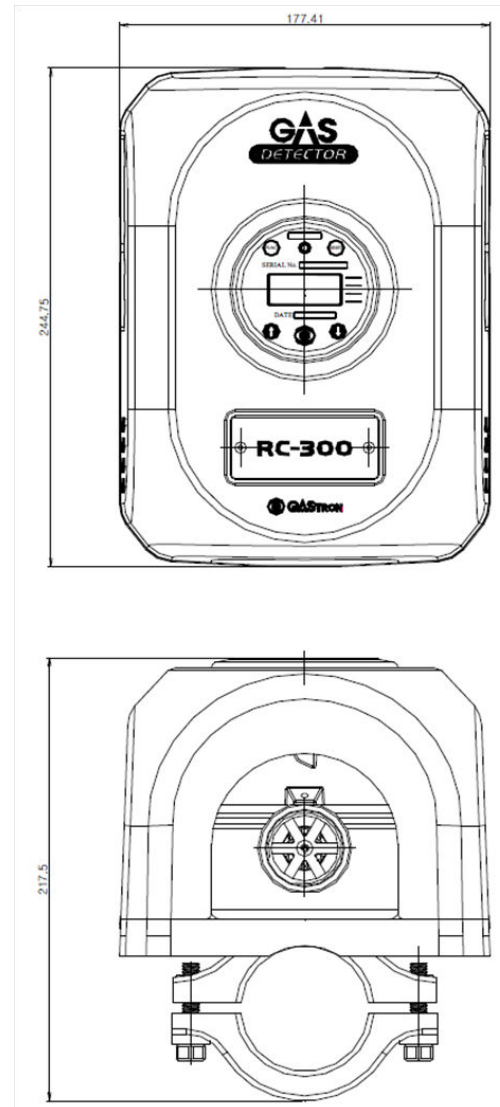

[Figure 14. Outline drawing of coupling of Raincover for GTD-2000Ex]

10.1. Selection of installation place(Data from occupational safety and health regulations)

The place to install the gas leakage detection alarm is as follows.

- Surroundings of chemical equipment or accessory equipment with a risk of gas leakage such as compressor, valve, reactor, piping connection part, etc. dealing with combustible and toxic substances that are installed inside and outside buildings
- Places for easy dwelling of gas around manufacturing equipment with ignition sources such as heating furnace, etc.
- Surroundings of connection part of charging equipment for combustible and toxic substances
- Substation, power distribution panel room, control room, etc. positioned within explosion-proof area
- Other places for especially easy dwelling of ga

10.2. Selection of installation place (Data from safety management regulations for high-pressure gas)

Gas detector for gas leakage detection alarm should be installed close to the leakage parts with a risk of gas leakage. However, for the places with easy dwelling of leaked gas although direct gas leakage is not expected, it should be installed at a spot such as No. 1 of the following places.

- Gas leakage detection alarm installed outside a building shall be installed at a spot for easy dwelling of gas by considering wind direction, wind velocity, specific gravity of gas, etc.
- When the specific gravity of the detection target gas is larger than that of air, the gas leakage detection alarm installed inside a building should be installed at a lower part in the building, while it should be installed near ventilation hole of the building or at an upper in the relevant building when the gas is lighter than air.
- Alarm of the gas leakage detection alarm should be installed at a place with the Gas detector installed and a places for permanent residence of workers.

10.3. Notes upon installation

Positions with rainwater, etc. that can be an electrical obstacle should be avoided for installation, and installation at a place facilitating operation is recommended since periodic maintenance and repair is required. Since places with vibration or impact can affect output values, avoid those places with vibration or impact for installation, and install in such a way that the detector unit is directed toward the direction of gravity.

- The present instrument has a pressure-resistant, explosion-proof structure, belonging to the GROUP II aimed at gas, vapor of general business places and chemical plants, and can be used for dangerous places of ZONE 1(ONE)-type and of ZONE 2(TWO)-type 2.
- Allowed temperature belong to lower than 85°C corresponding to T6
- In terms of ambient temperature, use in the range of -20 to 50 °C.
- Installation altitude: Less than 1,000M above sea level
- Relative humidity: 5% ~ 99%(Non-condensing)
- Installation place: Outdoors and indoors
- Explosion ignition group of target gas or vapor: Ex d IIC T6
- When explosion-proof cable grand is used at cable inlet or wiring construction for metal cable pipe is conducted upon wiring connection operation, electric conduit should be sealed to prevent moving of gas, etc. through electric cable conduit within 50mm or propagation of flames upon explosion, and products having passed safety s=certification should always be used for all materials and the materials used for finishing of unused lead-in unit
- More than 5 threads should be made to be coupled upon connection of the present instrument and the electric cable pipe
- Conduct operation under the conditions satisfying other [Standards on selection, installation, and repair, etc. of electric machine, apparatus, wiring, etc. with explosion-proof structure for business places.

VERSION	CONTENTS	DATE
0.0	* Manual revised initially	2011.12.28
1.0	* Outline drawing and function added	2012.06.17
1.1	* Font changed	2016.03.12
1.2	1> SPAN SKIP menu added 2> Sensor for INSERT TYPE SENSOR added 3> FALUT 8 added	2016.08.16
2.0	* Factory mode manual separated	2016.09.27
3.0	* Installation regulation for Cable Entry in explosion-proof instrument changed 45cm → 50mm	2017.01.20
3.1	1> Marking Error for 4-20 Analog Output revised 2> Output changed upon Maintenance mode	2017.05.04
3.2	* Changed detailed operation revised, warning statement added	2017.11.10

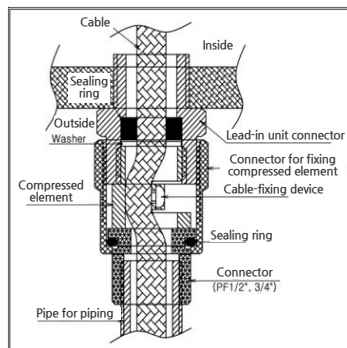

[Figure 15. Pressure-resistant packing type]

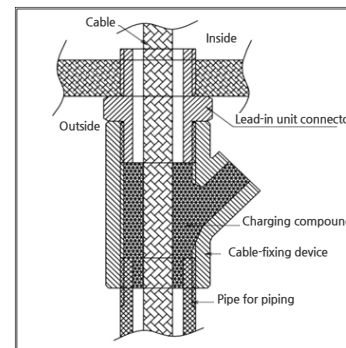

[Figure 16. Y Sealing Compound]