



Headquarters / Engineering research laboratory :  
23 Gunpo Advanced Industry 1-ro(Bugok-dong), Gunpo-si, Gyeonggi-do  
Tel +82-31-490-0800 Fax +82-31-490-0801

Yeongnam business office / Plant :  
55 Gonghangap-gil 85beon-gil, Gangseogu, Busan Metropolitan City  
Tel +51-973-8518 Fax +51-973-8519

E-mail : info@gastron.com

www.gastron.com

# GTD-2000ExW

## Instruction Manual



Read in detail for correct use.

# Gas & Flame Detection System

**GASTRON**



In case of a problem after purchasing the product,  
please contact the address below.

- Address : 23 Gunpo Advanced Industry 1-ro,  
Gunpo-si, Gyeonggi-do
- Tel : 031-490-0800
- Fax : 031-490-0801
- URL : [www.gastron.com](http://www.gastron.com)
- e-mail : [info@gastron.com](mailto:info@gastron.com)

## Thank you very much for purchasing a product from GasTron Co. Ltd.

We, GasTron, specialize in Gas Detector & Gas Monitoring System and have been recognized by many customers for the best quality and ease of use. We always seek to help our customers to find the product they need and we continuously research to develop a gas detector that satisfies our customers. From now on, you can solve all problems related to gas detectors with a GasTron product. We, GasTron, will be responsible for your satisfaction.

This user manual describes operation and simple maintenance methods etc. for the gas detector. Please read carefully and store it in a safe place. Using it as a reference will help a lot when you have a question during use.

- For a precise operation of the gas detector, please perform an inspection and a calibration at least once per 6 months.  
(\* In reference to KOSHA GUIDE: P-135/6-2018 / 7.2 In-house inspection, section 2)
- For a precise operation of the gas detector, inspection and calibration using a reference gas before measurement is recommended.
- Failure to calibrate may result in malfunction of the equipment due to aging of the sensor.
- Only an individual specialized in gas detector may disassemble the device.
- Wire specification for the power cable must be decided in reference to the "Installation cable length" section.
- Please contact our company's technical support, e-mail, or website for inquiries related to inspection and calibration of the gas detector.

The product and manual are subject to change without a notice for the product's functional improvement and ease of use.

\* KOSHA GUIDE : P-135/6-2018

Calibration must be performed at a frequency requested by the manufacturer and shall be performed quarterly when the calibration period is not specified.

<b>1. Overview</b> .....	6		
<b>2. Configuration</b> .....	6		
<b>3. Specifications</b> .....	7		
3.1. Basic Specification .....	7		
3.2. Mechanical Specifications .....	7		
3.3. Electrical Specifications (Standard Type) .....	8		
3.4. Environmental Specifications .....	8		
<b>4. Name and Description of Each part</b> .....	9		
4.1. Components .....	9		
4.2. LAMP Function Description .....	11		
<b>5. Installation</b> .....	12		
5.1. Detachment of Housing Cover .....	12		
5.2. Main PCB Configuration .....	13		
5.2.1. Wiring for 4~20mA Source Operation Type .....	15		
5.2.2. Wiring for 4~20mA Sink Operation Type .....	15		
5.2.3. Wiring for 4~20mA 3Wire Sink Operation Type .....	16		
5.3. Installation Cable Length .....	16		
<b>6. Detector Operation Flow</b> .....	18		
6.1. Initial Operation Status (Power On) .....	18		
6.2. Measuring Mode .....	18		
6.3. Operation Flow .....	19		
6.4. Menu Configuration Table .....	20		
<b>7. System Mode</b> .....	21		
7.1. PROGRAM MODE .....	21		
7.2. CALIBRATION MODE .....	22		
		7.2.1. Zero Calibration .....	22
		7.2.2. Span Calibration .....	23
		7.3. ALARM MODE .....	24
		<b>8. Troubleshooting</b> .....	26
		8.1. Fault List .....	26
		8.2. Recovery List .....	26
		<b>9. Drawings and Dimensions</b> .....	27
		9.1. Standard Type .....	27
		9.2. Warning light GTL-100 .....	28
		9.3. When Connecting Warning Light .....	29
		<b>10. Precautions before Installation</b> .....	30
		10.1. Selecting a Place for Installation (Occupation Safety and Health Act Data) .....	30
		10.2. Selecting a Site for Installation (High-Pressure Gas Safety Control Act Data) .....	30
		10.3. Precautions during Installation .....	30
		<b>11. Revision History</b> .....	32

GTD-2000ExW flammable gas detector has been developed to detect gas leaked from industrial sites and various flammable gases generated from factories, gas storages, and manufacturing processes that produce or use toxic gases and to prevent accidents in advance.

GTD-2000ExW flammable gas detector is installed in areas with gas leak hazards and continuously monitors gas leak. It displays measurements on LCD of the detector, converts and transmits data in DC 4~20 mA standard output signal. Also, for DC 4~20 mA standard output, output signal transmission length between detector and receiver can be connected up to 2,500 m. (When Cable CVVS or CVVSB 1.5sq and higher is used.) GTD-2000Ex flammable gas detector must be used at a height below 1,000 m above sea level.

## 2. Configuration

Body of GTD-2000Ex is made of Aluminum alloy and the gas sensor module is made of stainless steel. It consists of a complete explosion-proof enclosure (Ex d IIC T6). This product can be installed in areas with combustible gas leak and explosion hazards. It has built-in display (LCD or OLED) on the detector to display gas leak status at installed site. Internal configuration consists of display part that indicates measurements, terminal part that output measurements (DC 4~20 mA) externally, and a PCB board. External configuration consists of sensor that detects gas leak, cable inlet, and high-pressure explosion proof small warning light made of SUS materials. It uses magnet-bar outside the main body of detector enabling calibration from the outside of the detector, thus, maintenance is convenient.

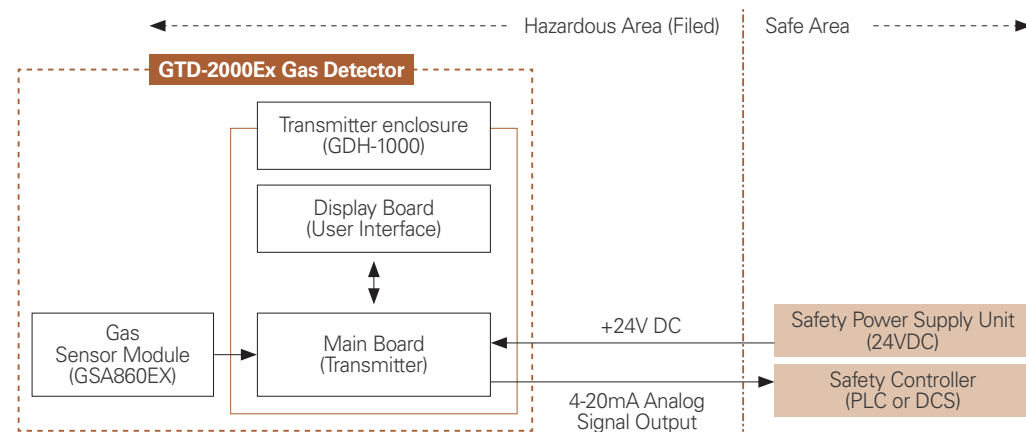

[Figure 1. GTD-2000ExW Overview]

## 3.1. Basic Specifications

ITEMS	SPECIFICATION	
Measuring Type	Diffusion	
Measuring Value Display	- LCD or OLED Display - Green, Red, Yellow LED - Sound Output(95dB)	
Measuring Method	Catalytic Cell Thermal Conductivity Cell Heated-semiconductor Cell	
Detectible Gas	가연성 가스(Flammable gas)	
Measuring Range	0~100% LEL	
Accuracy	≤ ±3% / Full Range	
Zero Drift	≤ 2% / Full Range	
Response Time	90% of full Scale in less than 15 sec	
Approvals Classification	KCs: Ex d IIC T6, T5, T4 ATEX/IECEX: II 2 G Ex d IIC Gb T4~T6 SIL2, MED, ABS, DNV	
Basic Interface	Analog 4-20mA current interface	
HART Interface	HART REV7 (Option)	
Option	HART Board	
Warranty	Transmitter & Lamp	2Years
	Sensor	1Year

## 3.2. Mechanical Specifications

ITEMS	SPECIFICATION	
Explosion-Proof Type	Explosion-Proof Enclosure	
Dimension	- Transmitter: 136(W) × 166(H) × 110(D) mm - Lamp: 83.8(W) × 85(H) × 48(D) mm	
Weight including Sensor	App. 2.2kg	
Mounting Type	Wall mount	
Mounting Hole	Ø 7 ±0.1	
Cable Inlet	3/4" PF (1/2" or 3/4" NPT)	
Body Material	Transmitter	Aluminum Alloy
	Sensor	Stainless Steel (STS316)
	Lamp Cover	PC
	Lamp Body	Stainless Steel (SUS304)

#### 3.3. Electrical Specifications (Standard Type)

ITEMS	SPECIFICATION	
Input Voltage(Standard) ※ Customer supplied PSU must meet requirements IEC1010-1 and CE Marking requirements.	Absolute min: Nominal: Absolute max: Ripple maximum allowed:	18V 24V 31V 1V pk-pk
Wattage	Max. wattage: Max. current:	4.8W @+24 VDC 200mA @+24 VDC
Analog output Current	0-20mA(500 ohms max load) All readings ± 0.2mA Measured-value signal: 4mA(Zero) to 20mA(Full Scale)	
	Fault: 0-100% LEL: 100-109%LEL: Over 110% LEL: Maintenance:	0mA 4mA - 20mA 20mA - 21.4 mA 22mA 3mA
Analog output current ripple & noise max	±20uA	
Wiring requirement	Power	CVVS or CVVSB with shield
	Analog	CVVS or CVVSB with shield
Cable Connection Length	Analog	2500m
EMC Protection:	Complies with EN50270	

#### 3.4. Environmental Specifications

ITEMS	SPECIFICATION	
Operation Temperature	Transmitter	-40 to 80 °C
	Sensor	Refer to Sensor Specification
Storage Temperature	Transmitter	-40 to 80 °C
	Sensor	Refer to Sensor Specification
Operation Humidity	Transmitter	5 to 99% RH (Non-condensing)
	Sensor	Refer to Sensor Specification
Pressure Range	90 to 110KPa	
Max. air velocity	6m/s	

#### 4.1. Components

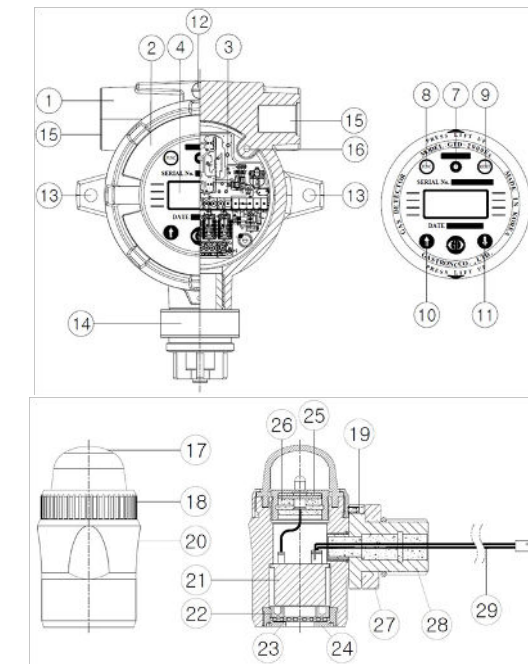

[Figure 2. GTD-2000ExW Components]

No	NAME	DESCRIPTIONS
1	Housing Body	Protects PCB Board built in Sensor and Housing from external environmental change and shock.
2	Housing Cover	Top surface is built with circular glass to enable monitoring of measurement displayed on LCD.
3	MAIN PCB	Amplifies fine outputs generated from Sensor Element to transmit a converted output in 4~20 mA DC standard. It sends data to display part.
4	Display PCB	Displays data (measurement) sent from Main/ Terminal (Transmitter) PCB on LCD and displays power status with a power lamp.
5	Power/Signal Terminal	CN8 consists DC18V~31 24 V power supply and DC 4~20 mA standard output connection terminal (VISO, +24V, mA, GND, ETH).
6	Sensor Terminal	CN4 is Sensor Connection Terminal.
7	Power LED	It is lamp that turns on when power is supplied.
8	Function Key	It is used to enter function setting mode from gas measuring mode by contacting magnet-bar for 2 sec or longer. It is also used to save changed data from function setting mode.

### 4.1. Components

No	NAME	DESCRIPTIONS
9	Reset Key	To cancel or return to the previous status during Parameter setting, use the Magnet-Bar and touch once. (Each touch returns to the previous status by one unit.)
10	↑(UP) Key	During conversion of mode or number, use the Magnet-Bar and touch once. Each touch converts or increases displayed value by one unit.
11	↓(DOWN) Key	During conversion of mode or number, use the Magnet-Bar and touch once. Each touch converts or increases displayed value by one unit.
12	External Earth Ground	It must be grounded to outside of detector for protection from external noise or strong electric field. Use a conductor that is 4 mm or longer when coupling ground line.
13	Mount Hole	Hole to fix the gas detector on external wall or other installation sites.
14	Sensor	It is a site that detects actual gas leak. It converts the amount of gas leak into electrical signal and transmits to the Main PCB.
15	Conduit Connection	It is supplied for inlet of power supply and measurement output signal for the detector during installation. For cable inlet, PF or NPT 3/4", 1/2" are prepared.
16	Internal Ground	It must be grounded to inside of detector for protection from external noise or strong electric field. Use a conductor that is 4 mm or longer when coupling ground line.
17	FRONT CASE	It is an explosion-proof case made of explosion-proof plastic and emits LED light externally through transparent window.
18	CASE RING	It serves as a cover to prevent deviation of front case.
19	SEXANGLE BOLT	It serves to prevent deviation after case ring assembly and is fixed by mood bolt.
20	CASE BODY	It is the main body that protects internal buzzer and other parts by body.
21	BUZZER	It receives signal upon an event of error and generates warning sound.
22	FIXED RING	It prevents deviation of sinter filter upon external shock.
23	FLAME ARRESTER	It blocks flow in of dust, debris, water, gas and delivers warning sound from the buzzer to outside.
24	ARREST CAP	It protects sinter filter from external shock.
25	LED COVER	It is a joint for LED PCB ASS'Y and covered with moulding.
26	LED PCB ASS'Y	It is a multi-color LED that displays status.
27	NUT	It serves to fix parts to the compliment part.
28	SHAFT BODY	It serves to fix parts to the opponment.
29	CABLE WIRE	It supplies power and transmits data.

[Table 1. GTD-2000ExW Transmitter Components Description]

### 4.2. LAMP Function Description

- In normal status, green LED lights on and buzzer does not ring.
- When Alarm-1 signal is received, red LED flickers in 1 sec interval and buzzer rings in 1 sec interval.
- When Alarm-2 signal is received, red LED lights on and buzzer rings continuously.
- When Trouble signal is received, yellow LED lights on and buzzer does not ring.

It is prohibited for an individual, other than an approved user or a technician responsible for installation and repair from the head office, to install a gas leak detector on site or open the cover of the installed gas leak detector and manipulate it. This may cause serious loss of life and property from fire, explosion, and etc. In addition, please check whether there is any remaining explosive gas or combustible material in the surroundings. Power must be turned off before performing work.

### 5.1. Detachment of Housing Cover

- <Warning - Do not open when electrical current is flowing>
  - Turn the slotted set screw (M4 x 1ea) fixing the cover part of main body 3~4 turns counter clockwise(ccw) using a hex wrench (M2) then turn the cover of gas leak detector ccw to detach the cover.
- When the cover is detached, LCD appears.

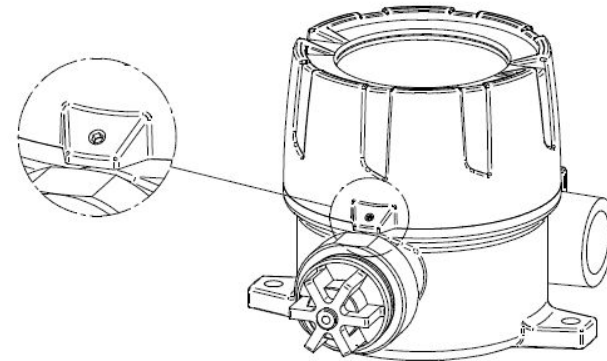

[Figure 3. Slotted Set Screw]

- After detaching the cover, disassemble the display parts as below.
  - ① Push in left and right fixing rings located on front side of LCD at the same time.
  - ② While pushing, pull the display parts towards the front to detach from gas detector body.
  - ③ After detaching the display parts, the Main PCB is installed at the bottom part of the detector body.

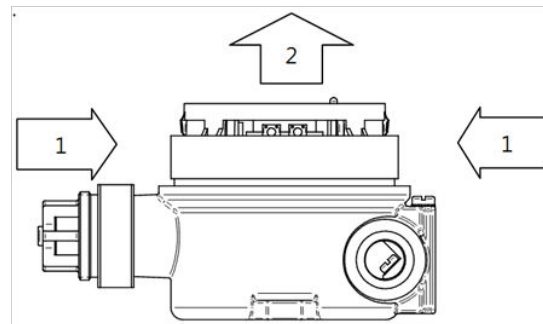

[Figure 4. Display Part Detaching Method]

### 5.2. Main PCB Configuration

- After detaching the display parts, the Main PCB terminal layout appears as shown in the figure below.

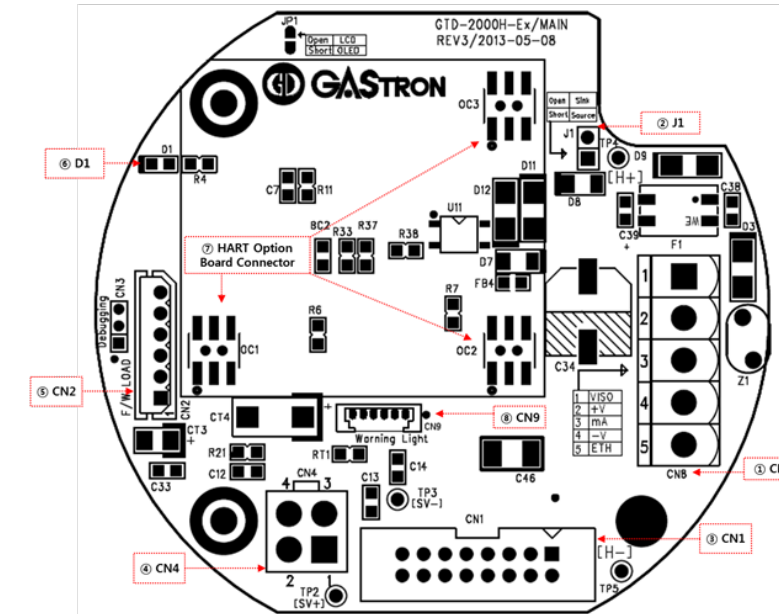

[Figure 5. Main PCB Terminal Layout]

No	NAME	DESCRIPTION
1	CN8	Power & Output Signal Terminal
2	J1	4~20mA Source / Sink Selection Jumper ( ON: Source Type, OFF: Sink Type)
3	CN1	Display LCD Connector
4	CN4	Sensor Connector
5	CN2	Program download Connector
6	D1	Status LED (Flashes in 1 sec interval during normal operation)
7	CN5,CN6,CN7	HART Option Board Connector
8	CN9	Warning light (GTL-100) Interface Connector

[Table 2. Main PCB Key Part Description]

- Using CN5, CN6, and CN7 shown in the layout above, HART option board can be attached and 3ØScrew holes located at top left of HART option board are used for fixing.
- After disassembling display parts, there is a terminal block in the Main PCB as shown in the figure below. Holding it with hands and pulling towards ceiling detaches it from the Main PCB.
- <Warning - Turn off power before connecting power terminal>
- Loosen 5 terminal fixing screws located at top part of detached terminal block CN8 (VIS, +, mA, -, ETH) Connector by turning counter-clockwise using a  $\Theta$  driver. Connect DC 18~24 V power to +, and - then connect signal cable to mA. Tighten 5 terminal fixing screws clockwise so that terminal does not leave the track then insert Main PCB as the same condition before disassembly.

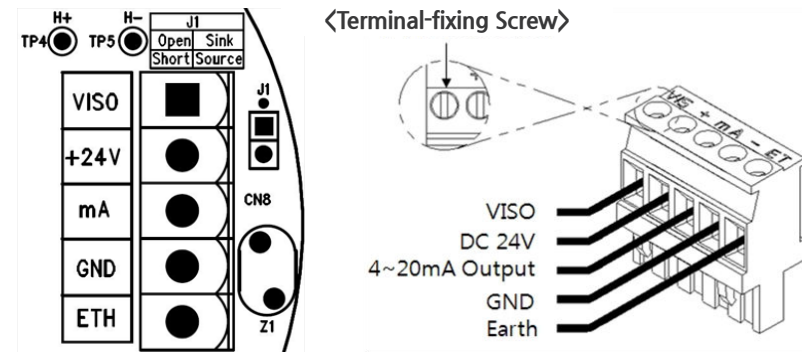

[Figure 6. CN8 Terminal Configuration]

NO	PCB SILK	PIN NAME	DESCRIPTION	
			4~20mA Source Drive (J1 Jumper ON)	4~20mA Sink Drive (J1 Jumper OFF)
1	VISO	VIS	N.C	4~20mA Sink In(+)
2	+24V	+	+24V / POWER (+)	
3	mA	mA	4~20mA Source Out	4~20mA Sink Out(-)
4	GND	-	GND / POWER (-)	
5	ETH	ET	EARTH	

[Table 3. CN8 Terminal Detailed Description]

- Use CVVS or CVVSB 2.0sq $\uparrow$  Shield Cable for terminal configuration.
- To connect 4 Pin terminal from the existing old GTD-2000ExW model, connect terminals in reference to pin #2, which is +24V.

### 5.2.1. Wiring for 4~20mA Source Operation Type

- Connect 4-20 mA signal terminal at PLC side to 'mA' of GTD-2000Ex. GND terminal is used in common with power. Then, turn on the J1 jumper.
- HART Communicator can only be used in models using HART Option board.

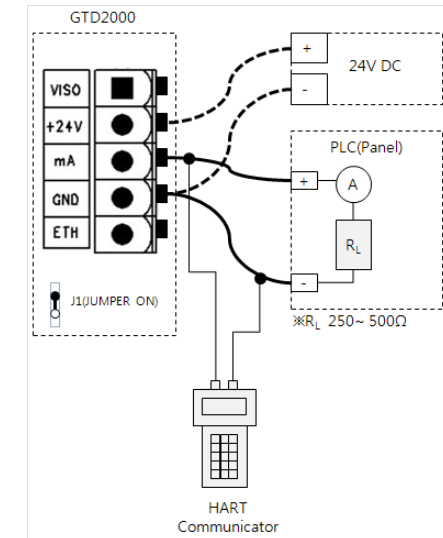

[Figure 7. 4-20mA Source Configuration]

### 5.2.2. Wiring for 4~20mA Sink Operation Type

- Connect (+) and (-) terminals for 4-20 mA sink output at PLC side to VISO terminal and 'mA' terminal, respectively. Then, turn off the J1 jumper.
- HART Communicator can only be used in models using HART Option board.

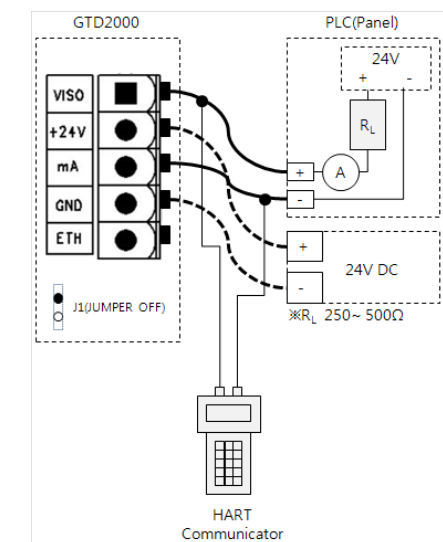

[Figure 8. 4-20mA Sink Configuration]



5.2.3. Wiring for 4~20mA 3Wire Sink Operation Type

- Connect (+) and (-) terminals for 4-20 mA sink output at PLC side to VISO terminal and power (24V DC) (-) terminal, respectively. Connect 'mA' terminal of GTD-2000ExW to 'GND' terminal. Then, turn off the J1 jumper.

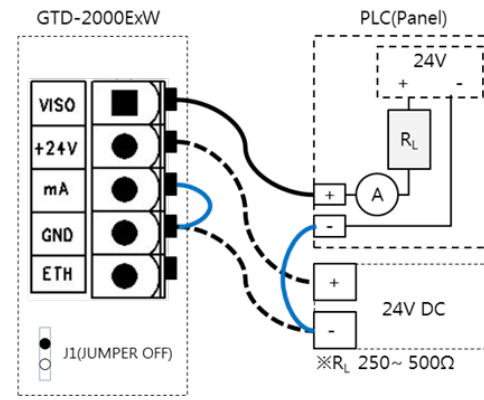

[Figure 9. 4-20mA 3Wire Sink Configuration]

5.3. Installation Cable Length

- The maximum length between GTD-2000ExW and power supply is decided by wire specification.
- Max. Installation Length =  $V_{MAXDROP} \div I_{MAX} \div WIRER/m \div 2$ 
  - VMAXDROP: Maximum Power Loop Voltage Drop (=Power Supply voltage - min operating voltage)
  - IMAX : Max. Current of GTD-2000ExW
  - WIRER/m: The resistance of the wire (ohms/meter value available in wire manufacturer's specification data sheet)
- Example of installation lengths using 24 V power supply and 16 AWG is as follows.
  - GTD-2000ExW minimum operating voltage = 18 Vdc
  - VMAXDROP = 24 - 18 = 6V
  - IMAX = 0.2A (200mA)
  - $6 \div 0.2 \div 0.01318 \div 2 = 2276m \approx 2.000m$

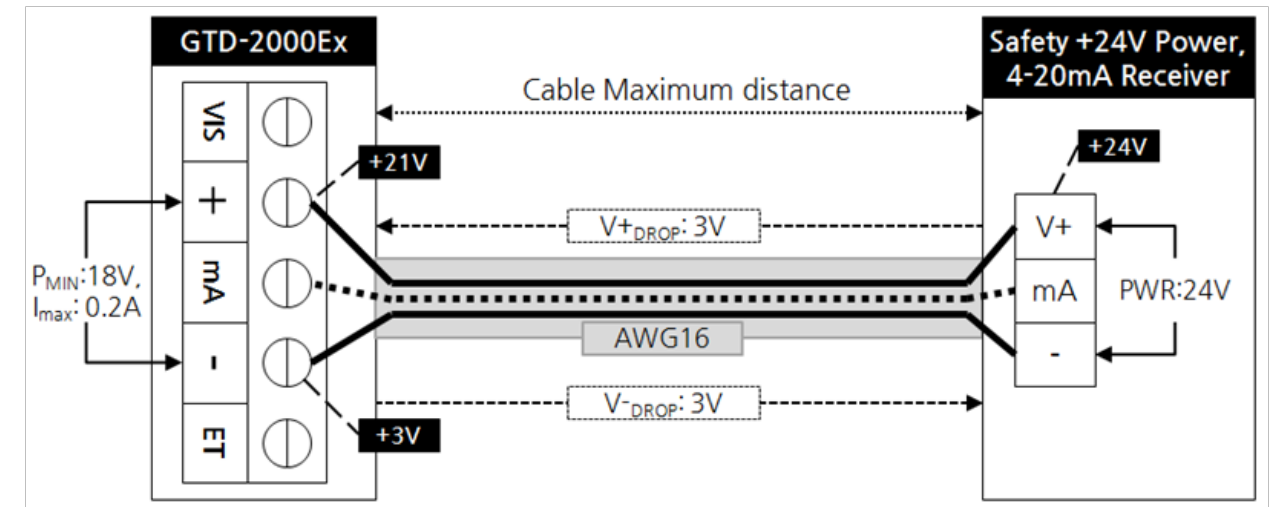

[Figure 10. Calculation of GTD-2000ExW Installation Cable Length]

- Power cable installation for each cable type is as shown in the table below.

AWG	mm2	COPPER RESISTANCE(ohms/m)	METERS
12	3.31	0.00521	2879
14	2.08	0.00828	1811
16	1.31	0.01318	1138
18	0.82	0.02095	715
20	0.518	0.0333	450

[Table 4. GTD- 2000ExW Power Cable Installation Length]

### 6.1. Initial Operation Status (Power On)

- After wiring to power terminal at the top of Main PCB board then supply power, the following contents are displayed on LCD. Approx. 30 m of stabilization of time is needed from the initial supply of operation power and it starts to operate normally after sufficient stabilization.

<b>GTD-2000</b> <b>[V X,XX]</b>	- When power turns on, model name and product firmware version are displayed on LCD (OLED).
<b>SELF TEST</b> <b>[&gt;&gt;&gt;&gt;0179]</b>	- Self test is performed for 3 min '>' symbol in the second row shows the progress.

### 6.2. Measuring Mode

- After power on, when there is no error from "SELF TEST", it automatically enters Measuring Mode.

<b>[ %LEL]</b> <b>[ 0.0]</b>	- In normal operation mode, it runs as below. - In the first row, measured gas name and unit are displayed in 1 sec interval. In the second row, the current measurement is displayed. - In the current screen, touching the magnet-bar on 'Func' key for 2 sec or longer changes to setting mode.
<b>[ COMB.]</b> <b>[ 0.0]</b>	※ During Modbus network, '*' is displayed on the left of the first row. ※ ENG. When the mode is on, '<' is displayed on the left of the second row.
<b>[ %LEL]</b> <b>[ 30]</b>	- When Alarm 1 or 2 occurs, it runs as below. (It only runs when ALARM EN setting in Maintenance Mode is ON) - The first row runs the same as in normal status. In the second row, alarm message and gas measurement are displayed in 1 sec interval.
<b>[ %LEL]</b> <b>[ ALARM1 ]</b>	- When GTL100 explosion-proof warning light is installed, upon an event of alarm1, red LED and buzzer flicker and run in 1 sec interval. Upon an event of alarm2, they continuously run without flickering. - If alarm latch is on, the alarm continuously run until it is released using the reset key.
<b>[ %LEL]</b> <b>[ OVER ]</b>	- When gas measurement larger than 10% of set high scale value, "OVER" displays in 1 sec interval. At this time, 4~20 mA runs as 22 mA.
<b>[ %LEL]</b> <b>[ UNDER ]</b>	- When gas measurement smaller than -10%, "UNDER" displays in 1 sec interval and 4~20 mA runs below 2 mA. ※ The following function only runs when UNDER is on.
<b>[FAULT1]</b> <b>SEN EMPT</b>	- When trouble occurs in the device, it displays fault number and message. - At this time, 4~20 mA runs below 2 mA. - It is a mode that displays when Fault #1 sensor on the left is not equipped.

### 6.3. Operation Flow

- After power on, it passes self-test then enters Measuring Mode. Here, by operating front keys, you can go to internal System Mode.
- Timeout for Level1 and Level2 are 10 sec. It is set to 1 hour for Level2 Calibration and Test Mode.
- When "RESET" key contacts at Program Mode Screen, it returns to Measuring Mode. When "RESET" key contacts at each Program Setting Screen, it returns to the parent step.

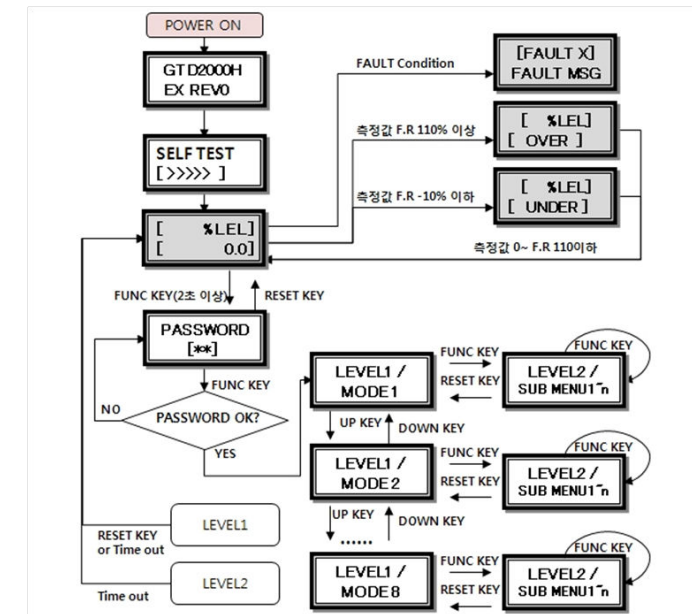

[Figure 11. GTD-2000ExW Mode Configuration]

- Operation keys for detector system mode are defined as below.

ITEM	NAME	DESCRIPTION
FUNC	Function key	Detector Mode Setting Entry Function (Insert Magnetic-bar for 2 sec or longer in measuring mode) Level2 Next stage entering function and setting saving function
RESET	Reset key	Move to the previous stage from the level entered.
↑	Up key	Next level mode that is configured in LEVEL1 and Change in Level2 setting Plus
↓	Down key	Next level mode that is configured in LEVEL1 and Change in Level2 setting Minus

6.4. Menu Configuration Table

LEVEL1	LEVEL2		DEFAULT
	NAME	PARAMETER	
PROGRAM MODE	GAS TYPE (Gas Type)	[DEFIN./USER]	DEFIN.
	GAS SEL(Gas Select)	Built-in gas name selection	COMB.
	UNIT SEL (Unit Select)	%/%LEL/PPM/PPB	%LEL
	D-POINT(Decimal Point)	0.100/1.00/10.0/100	100
	HIGH SCL (High Scale)	1~10000	100
	PASSWORD	00~99	00
CALIBRA. MODE (Calibration Mode)	CALIBRA. [ZERO] (Calibration Zero)	ZERO CAL [NO,YES]	[NO]
		ZERO GAS [ 0]	
		ZERO >>>> [SUCCESS / FAIL]	
		CAL. DATA [ 0/ FAIL]	
	CALIBRA. [SPAN] (Calibration Span)	SPAN CAL [NO, YES]	[NO]
		SPAN GAS [ 0]	
		SPAN SET [ 50/ FAIL]	50
		SPAN >>>> [SUCCESS / FAIL]	
	CAL. DATA [ 0]		
ALARM MODE	ALM USED (Alarm Used)	[OFF / ON]	OFF
	AL LATCH (Alarm Latch)	[OFF / ON]	OFF
	A1 LEVEL (Alarm-1 Level)	[1 ~ Full SCL]	20
	A1 TYPE (Alarm-1 Type)	[INC / DEC]	INC
	A1 DBAND (Alarm-1 Dead Band)	[0.0 ~ 10.0%F.S]	0
	A1 TIME (Alarm-1 Time)	[0~ 60]SEC	1
	A2 LEVEL (Alarm-2 Level)	[1 ~ Full SCL]	40
	A2 TYPE (Alarm-2 Type)	[INC / DEC]	INC
A2 DBAND (Alarm-2 Dead Band)	[0.0 ~ 10.0%F.S]	0	
	A2 TIME (Alarm-2 Time)	[0~ 60]SEC	1
SENSOR MODE	Factory Setting		
MAINTEN.MODE	Factory Setting		
DEVICE MODE	Factory Setting		
VERSION MODE	Factory Setting		
TEST MODE	Factory Setting		

7.1. Program Mode

<b>PASSWORD [**]</b>	- Contacting "FUNC" key with the Magnet-bar for 2 sec or longer in Measuring Mode enters Password mode. - After setting Password using "↑" or "↓" key, contact "FUNC" key.
<b>PROGRAM MODE</b>	- If password is correct, it enters Program mode. - By contacting "↑" or "↓" key, mode changes in defined order. ( PROGRAM -> CALIABRA. -> ALARM -> SENSOR -> MAINTEN. -> DEVICE -> VERSION -> TEST )
<b>GAS TYPE [ DEFIN. ]</b>	- Mode that sets gas name type and contacting "↑" or "↓"key changes gas type. (DEFIN. / USER) - DEFIN. Is acronym for Define and is selected when using built-in setting of gas name. USER is selected when the user directly sets a gas name. - When a desired gas type is displayed, contact "FUNC" key to set the gas name and enter Program Mode.
<b>GAS SEL [ COMB. ]</b>	- Mode that sets gas name and contacting "↑" or "↓"key changes gas name. - When gas type is set to DEFIN., built-in gas names can be selected for use. When it is set to USER, the user shall set gas name using 5 character for use. Characters allowed for use are number, capital Alphabet, space, and period. When position is moved by setting characters, a cursor in black box shape appears as shown in the figure on left.
<b>USER GAS [ ■SER ]</b>	
<b>UNIT SEL [ %LEL ]</b>	- Mode that sets gas measuring unit and contacting "↑" or "↓"key changes gas measuring unit. ( % / %LEL / PPM / PPB ). - When a desired gas measuring unit is displayed, contact "FUNC" key to set the unit and enter Program Mode.
<b>D-POINT [ 100 ]</b>	- Mode that changes decimal place and contacting "↑" or "↓"key changes decimal place. (0.100/1.00/10.0/100) - When a desired decimal place is displayed, contact "FUNC" key to set the decimal place and enter the next Program Mode.
<b>HIGH SCL [ 100 ]</b>	- Mode that sets high scale value that should be displayed for full range. Contacting "↑" or "↓"key increases or decreases the scale value. ( 1 ~ 10000 ) - When a desired high scale is displayed, contact "FUNC" key to set the high scale value and enter the next Program Mode.
<b>PASSWORD [00]</b>	- It is password setting mode. This password is checked when entering Program Mode. - Set using "↑" or "↓" key then contact "FUNC" key to set the password and enter the next Program Mode.

### 7.2. Calibration Mode

- Due to characteristics of the gas detector, minimum 30 min of stabilization time is required and maintenance condition may change depending on site condition.

#### 7.2.1. Zero Calibration

<b>PASSWORD [**]</b>	- Contacting "FUNC" key with the Magnet-bar for 2 sec or longer in Measuring Mode enters Password mode. - After setting Password using "↑" or "↓" key, contact "FUNC" key.
<b>CALIBRA. MODE</b>	- Contact "↑" or "↓" key to select "Calibration Mode". - Contact "FUNC" key when "CALIBRA. MODE" is displayed to enter Calibration Mode. - Contact "RESET" key to return to Measuring Mode.
<b>CALIBRA. [ZERO]</b>	- When "CALIBRATION MODE" is displayed, contacting "FUNC" key selects Zero Calibration. - Contact "↑" or "↓" key to achieve [ZERO] then contact "FUNC" key to enter Zero Calibration.
<b>ZERO CAL [ NO]</b>	- Contact "↑" or "↓" key to achieve [YES] then contact "FUNC" key to perform Zero Calibration.
<b>ZERO GAS [ 0]</b>	- Using a calibration tool, inject clean air or 100% nitrogen into the sensor at a flow rate of 500 mL/min for 1 min. Contact "FUNC" key when measurement is stabilized to automatically perform Zero Calibration.
<b>ZERO &gt;&gt; [SUCESS]</b>	- When zero calibration is successful, "ZERO SUCCESS" is displayed for 2 sec on LCD display then it changes to "CALIBRATION DATA" Mode.
<b>ZERO &gt;&gt; [ FAIL]</b>	- When zero calibration is not successful, "ZERO FAIL" is displayed for 2 sec and it changes to "Calibration Data Mode". - ZERO FAIL occurs when sensor input value exceeds 70% of total ADC input range.
<b>CAL.DATA [ 0]</b>	- It is a mode to display measurement after calibration and checks whether calibration is successful after performing auto calibration. - When it failed, it displays "FAIL" and the current measurement in 1 sec interval. - Contact "RESET" key to return to "Calibration mode".

#### 7.2.2. Span Calibration

<b>CALIBRA. MODE</b>	- Contact "↑" or "↓" key to select "Calibration Mode". - Contact "FUNC" key when "CALIBRA. MODE" is displayed to enter Calibration Mode. - Contact "RESET" key to return to Measuring Mode
<b>CALIBRA. [SPAN]</b>	- Contact "↑" or "↓" key to achieve [SPAN] then contact "FUNC" key to enter Span Calibration Mode.
<b>SPAN CAL [ NO]</b>	- Contact "↑" or "↓" key to achieve [YES] then contact "FUNC" key to perform Span Calibration.
<b>SPAN GAS [ 50]</b>	- Using a calibration tool, inject the standard gas to the sensor at a flow rate of 500 mL/min for 90 sec. After the measurement is stabilized, press "FUNC" key to enter the next mode.
<b>[ 50] [ 50]</b>	- When Hold function in Maintenance Mode is on, the current maximum SPAN gas value is held and displayed in the first row. - The current measurement is displayed in the second row.
<b>SPAN SET [ 50]</b>	- It is a mode to set standard gas value. When there is no "Fail" message, contact "↑" or "↓" key to set a value. - When the inject standard gas value is abnormal, it displays Fail message. Fail message is as follows. Fail message and span set value are displayed alternatively.
<b>SPAN SET LOW FAIL</b>	① "LOW FAIL" occurs when the difference between injected gas value and zero calibration value is below 1%.
<b>SPAN SET HIGH FAIL</b>	② " HIGH FAIL" occurs when injected gas value is above 95% of total ADC input range. - "RING FAIL" occurs when injected gas value runs in the current set span value, it exceeds 95% of ADC input range. The above FAIL messages are automatically released if the status is normal after adjusting SPAN value.
<b>SPAN &gt;&gt; [SUCESS]</b>	- After completing standard gas value setting, contacting "FUNC" key automatically runs Span Calibration. When it succeeds, "SPAN SUCCESS" is displayed on LCD display for 2 sec then it changes to "CAL DATA" Mode.
<b>SPAN &gt;&gt; [ FAIL]</b>	- When span calibration is not successful, "SPAN FAIL" is displayed for 2 sec and it changes to "Cal. Data Mode".
<b>CAL.DATA [ 0]</b>	- It is a mode to display measurement after calibration and checks whether calibration is successful after performing auto calibration. - Contact "RESET" key to return to "Calibration mode".

### 7.3. ALARM MODE

<b>PASSWORD [**]</b>	Contacting "FUNC" key for 2 sec or longer in Measuring Mode enters Password mode. After setting Password using "↑" or "↓" key, contact "FUNC" key.
<b>ALARM MODE</b>	Contact "↑" or "↓" key to select "Alarm Mode". Contact "FUNC" key when "ALARM MODE" is displayed to enter Alarm setting mode. Contact "RESET" key to return to Measuring Mode.
<b>ALM USED [ ON]</b>	It is a setting where Alarm Mode Setting is turned on or off. Contact "↑" or "↓" key to change ON/OFF status. When it is ON, Alarm function and Alarm Mode setting can be performed. GTL-100 explosion-proof warning light can only be used when it is ON. Contacting "FUNC" key enters the next mode.
<b>AL LATCH [ ON]</b>	It is a mode that sets Reset method after running of Alarm1. Contact "↑" or "↓" key to change "ON" and "OFF". "OFF" sets to automatically reset the alarm. "ON" set to reset the alarm only when Reset key is pressed. Contact "FUNC" key when a desired mode is displayed to set then enter the next alarm setting mode.
<b>A1 LEVEL [ 20]</b>	It is a mode that sets Alarm1 level. Contact "↑" or "↓" key to increase or decrease Alarm1 level, respectively. When a desired alarm 1 threshold is displayed, press "FUNC" KEY to set it and enter the next item.
<b>A1 TYPE [INC]</b>	It is a mode that sets operational direction of Alarm1. Contact "↑" or "↓" key to display "INC" or "DEC". "INC" mode operates when the value is equal or larger than set alarm threshold. "DEC" mode operates when the value is equal or less than set alarm threshold.
<b>A1 TYPE [DEC]</b>	Contact "FUNC" key when a desired mode is displayed to set then enter the next mode.
<b>A1 DBAND [ 0]%F</b>	It is a mode that sets Dead band value for Alarm1 operation. Use "↑" or "↓" key to set a value. It is a function where Alarm1 operates at values above the sum of Alarm1 level and dead band values and releases at values below Dead band value subtracted from Alarm1 level. When a desired alarm 1 dead band is displayed, press "FUNC" KEY to set it and enter the next item.
<b>A1 TIME 0 SEC</b>	It is a function to prevent instantaneous malfunction of detector due to external shock and noise other than from normal operation and time can be set in a range between 0~60 sec. For Alarm1 dwell time setting, press "↑" or "↓" key to increase or decrease in unit of 1 sec, respectively. When a desired Alarm 1 dwell time is displayed, press "FUNC" KEY to set it and enter the next item. Ex.) Alarm threshold value: 20% LEL / Delay time: When it is at 5 sec, Alarm triggers when the measured value is above the set value based on 20%LEL for 5 sec or longer. When it goes down below the set value within 5 sec, alarm is not triggered.
<b>A2 LEVEL [ 20]</b>	It is a mode that sets Alarm2 level. Contact "↑" or "↓" key to increase or decrease Alarm2 level, respectively. When a desired alarm 2 threshold is displayed, press "FUNC" KEY to set it and enter the next item.

<b>A2 TYPE [INC]</b>	It is a mode that sets operational direction of Alarm2. Contact "↑" or "↓" key to display "INC" or "DEC". "INC" mode operates when the value is equal or larger than set alarm threshold. "DEC" mode operates when the value is equal or less than set alarm threshold.
<b>A2 TYPE [DEC]</b>	Contact "FUNC" key when a desired mode is displayed to set then enter the next mode.
<b>A2 DBAND [ 0]%F</b>	It is a mode that sets Dead band value for Alarm2 operation. Use "↑" or "↓" key to set a value. It is a function where Alarm2 operates at values above the sum of Alarm2 level and dead band values and releases at values below Dead band value subtracted from Alarm2 level. When a desired alarm 2 dead band is displayed, press "FUNC" KEY to set it and enter the next item.
<b>A2 TIME 0 SEC</b>	It is a function to prevent instantaneous malfunction of detector due to external shock and noise other than from normal operation and time can be set in a range between 0~60 sec. For Alarm2 dwell time setting, press "↑" or "↓" key to increase or decrease in unit of 1 sec, respectively. When a desired Alarm 1 dwell time is displayed, press "FUNC" KEY to set it and enter the next item. Ex.) Alarm threshold value: 40% LEL / Delay time: When it is at 5 sec, Alarm triggers when the measured value is above the set value based on 40%LEL for 5 sec or longer. When it goes down below the set value within 5 sec, alarm is not triggered.

### 8.1. Fault List

FAULT MESSAGE	DESCRIPTION & CONDITION	CAUSE
FAULT1 "SEN EMPT"	Occurs when sensor module is disconnected.	Defective Sensor Module Connection
FAULT2 "SEN HIGH"	Toxic sensor output is above ADC max. value.	Defective sensor module or transmitter board ADC
FAULT3 "SEN LOW"	Toxic sensor output is below ADC min. value.	Defective sensor module or transmitter board ADC
FAULT4 "EROM ERR"	Defective Transmitter EEPROM Checksum	Defective Transmitter board EEPROM
FAULT5 "+24V LOW"	It occurs when 24 V main input power is inputted with voltage below 10 V.	Input power below 17 V or defective Transmitter ADC
FAULT6 "ADC FAIL"	Defective Transmitter ADC	Defective Transmitter ADC
FAULT7 "H/W REV"	H/W Version Error	Defective MPU inside Transmitter
FAULT8 "SEN HUNT"	When there is repeated hunting error in gas measurement, sensor output status may be poor or check for input power noise.	

[Table 5. Fault List]

### 8.2. Recovery List

NO	CAUSE	SOLUTION
1	Defective Sensor Module Connection	1) Check Sensor Connection and Connection status of the Connector 2) Change Sensor
2	Defective Sensor Module	Change Sensor
3	Defective Transmitter Board ADC	Change Transmitter Board
4	Defective Transmitter Board EEPROM	1) Perform Factory Initialization then correct parameter and re-calibrate 2) Change sensor unit when the same problem occurs again
5	Defective MPU inside Transmitter	Change Transmitter Main Board
6	Poor Sensor Output Status	Change Sensor
7	Check Input Power Noise	Check External Input Voltage Noise Status

[Table 6. Recovery List]

### 9.1. Standard Type

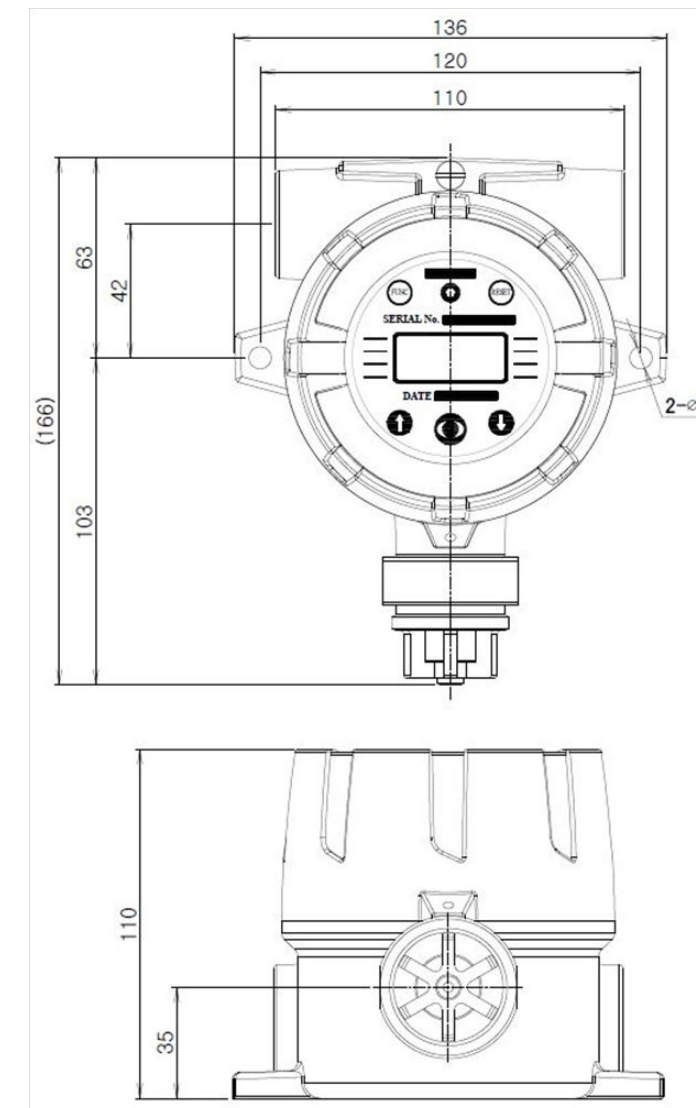

[Figure 12. GTD-2000ExW Standard Type Drawing]



### 10.1. Selecting a Place for Installation (Occupational Health & Safety Act Data)

A gas leak detector alarm shall be installed in the following places.

- Around chemical equipment and accessories that have concerns of gas leak. This includes compressors, valves, reactors, pipe joints, etc. installed inside and outside of a building that handle combustible and toxic materials.
- Places that are easier for gases to stay such as areas around manufacturing facilities with ignition sources like heating furnace, etc,
- Areas around equipment for filling combustible and toxic materials.
- Substations, panel rooms, control rooms, and etc. located within explosive area.
- Other areas that are easier for gases to stay.

### 10.2. Selecting a Site for Installation (High-Pressure Gas Safety Control Act Data)

Gas detector of gas leak detector alarm must be installed as close to the areas with concerns of gas leakage as possible. However, for areas where direct gas leakage is not expected but are easier for leaked gas to stay, the detector must be installed at the point 1 of the following.

- Gas leak detector alarm installed outside a building shall be installed at points where gas is likely to stay in consideration to wind direction, wind speed, specific gravity of gas, etc.
- Gas leak detector alarm installed inside a building shall be installed near the floor when the specific gravity of gas is heavier than air and near ventilation of ceiling when it is lighter than air.
- Alarm for gas leak detector alarm must be installed at sites where the gas detector is installed and workers are present.

### 10.3. Precautions during Installation

Avoid areas with electrical barriers such as rain water, etc. It is recommended to be installed in areas that are easier to work in since regular maintenance is needed. Avoid areas with vibration or shock since they can affect output values. Sensor part must be installed towards the direction of gravity.

- This equipment has explosion-proof construction for internal pressure and belongs to GROUP II for gas and vapor in general work sites and chemical plants. It can be used in ZONE 1 (ONE) and ZONE 2 (TWO) hazardous sites.
- Allowable temperature is 85°C or below, which corresponds to T6.
- Surrounding temperature shall be in a range of -40°C~ 80°C (for Main body. For sensor, refer to each sensor manual.)
- Installation Height: 1,000 M below sea level
- Relative Humidity: 5% ~ 99% (Non-condensing)
- Installation Site: Indoor and Outdoor
- Explosion Ignition Group for Target Gas or Vapor: Ex d IIC T6

- During wiring work, use explosion-proof cable gland at cable inlet or tightly seal cable conduit during metal cable wiring construction to prevent spread of flames in case of explosion or movement of gas, etc. through the cable conduit within 50 mm.  
All materials including materials used for sealing of unused inlets must have safety certificates!
- When connecting the equipment with cable, screw thread must be tightened 5 threads or more.
- Work in conditions satisfying other [Standards for Selection, Installation, and Maintenance, etc. of Explosion-proof Electric Machine and Equipment Wiring, etc. at Work Site]

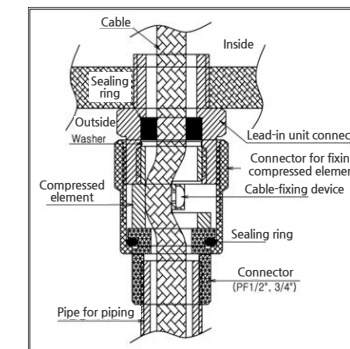

[Figure 15. High-Pressure Packing Type]

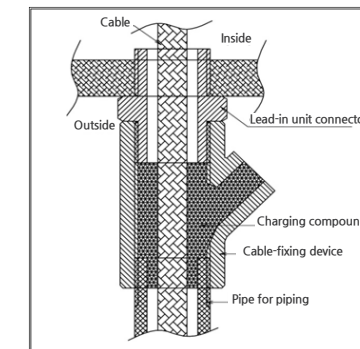

[Figure 16. Y Sealing Compound]



## 11. Revision History

VERSION	CONTENTS	DATE
0.1	* Manual Initial Revision	2017.09.29