

**GAS**TRON

Headquarters / Engineering research laboratory :  
23 Gunpo Advanced Industry 1-ro(Bugok-dong), Gunpo-si, Gyeonggi-do  
Tel +82-31-490-0800 Fax +82-31-490-0801

Yeongnam business office / Plant :  
55 Gonghangap-gil 85beon-gil, Gangseogu, Busan Metropolitan City  
Tel +51-973-8518 Fax +51-973-8519

E-mail : info@gastron.com

www.gastron.com

# GTD-2000Tx(2W)

## Instruction Manual



**GAS**TRON

**GAS**TRON

Read in detail for correct use.

# Gas & Flame Detection System

**GASTRON**



In case of a problem after purchasing the product,  
please contact the address below.

· Address : 23 Gunpo Advanced Industry 1-ro, Gunpo-si, Gyeonggi-do  
· Tel : 031-490-0800  
· Fax : 031-490-0801  
· URL : [www.gastron.com](http://www.gastron.com)  
· e-mail : [info@gastron.com](mailto:info@gastron.com)

## Thank you very much for purchasing a product from Gastron Co. Ltd.

Our Gastron Co.Ltd. is a company specialized in Gas Detector & Gas Monitoring System and have been recognized by many customers for the best quality and use convenience. We always seek to help our customers to find the product they need and we continuously research to develop gas detectors that satisfies our customers. From now on, you can solve all problems related to gas detectors with the products of Gastron. We Gastron will be responsible for your satisfaction.

This user manual describes operation and simple maintenance methods etc. for the gas detector. Please read carefully and store it in a safe place. Using it as a reference will help a lot when you have a question during use.

- For accurate operation of the gas detector, please perform an inspection and a calibration at least once per 6 months.  
( \* In reference to KOSHA GUIDE: P-135/6-2018 / 7.2 In-house inspection, section 2 )
- For accurate operation of the gas detector, inspection and calibration using a reference gas before measurement is recommended.
- Failure to calibrate may result in malfunction of the equipment due to aging of the sensor.
- Only an individual specialized in gas detector may disassemble the device.
- Wire specification for the power cable must be decided in reference to the "Installation cable length" section.
- Please contact our company's technical support, e-mail, or website for inquiries related to inspection and calibration of the gas detector.

The product and manual are subject to change without a notice for the product's functional improvement and ease of use.

\* KOSHA GUIDE : P-135/6-2018

Calibration must be performed at a frequency requested by the manufacturer and shall be performed quarterly when the calibration period is not specified.

<b>1. Overview</b> .....	6	<b>8. Drawings and Dimensions</b> .....	21
<b>2. Configuration</b> .....	6	<b>9. Precautions before Installation</b> .....	22
<b>3. Specification</b> .....	7	9.1. Selecting a Place for Installation (Occupation Safety and Health Act Data) .....	22
3.1. Basic Specifications .....	7	9.2. Selecting a Site for Installation (High-Pressure Gas Safety Control Act Data) .....	22
3.2. Mechanical Specifications .....	7	9.3. Precautions during Installation .....	22
3.3. Electrical Specifications (Standard Type) .....	8	<b>10. Revision History</b> .....	24
3.4. Environmental Specifications .....	8		
<b>4. Name and description of each part</b> .....	9		
4.1. Components .....	9		
<b>5. Installation</b> .....	11		
5.1. Detachment of Housing Cover .....	11		
5.2. Main PCB Configuration .....	12		
5.3. Power Signal and Terminal Configuration .....	13		
5.4. Method to Connect to External Control Unit .....	14		
5.5. Installation Cable Length .....	15		
<b>6. Detector Operation Flow</b> .....	16		
6.1. Initial Operation Status (Power On) .....	16		
6.2. Measuring Mode .....	17		
6.3. Operation Flow .....	18		
<b>7. System Mode</b> .....	18		
7.1. PROGRAM MODE .....	18		
7.2. CALIBRATION MODE .....	19		

GTD-2000Tx(2-wire) toxic gas detector has been developed to detect gas leaked from industrial sites and various toxic gases generated from factories, gas storages, and manufacturing processes that produce or use toxic gases and to prevent accidents in advance.

GTD-2000Tx(2W) toxic gas detector is installed in areas with gas leak hazards and continuously monitors gas leak. It displays measurements on LCD of the detector, converts and transmits data in DC 4~20 mA standard output signal. Also, for DC 4~20 mA standard output, output signal transmission length between detector and receiver can be connected up to 2,500 m. (When Cable CVVS or CVVSB 1.5sq and above is used.)

## 2. Configuration

Body of GTD-2000Tx(2W) is made of Aluminum alloy and the gas sensor module is made of stainless steel. It consists of a complete explosion-proof enclosure (Ex d IIC T6). This product can be installed in areas with combustible gas leak and explosion hazards. It has built-in LCD on the detector to display gas leak status at installed site. It consists of display part that indicates measurements, terminal part that output measurements (DC 4~20 mA) externally, and a PCB board. External configuration consists of detector part that monitors gas leak and cable inlets.

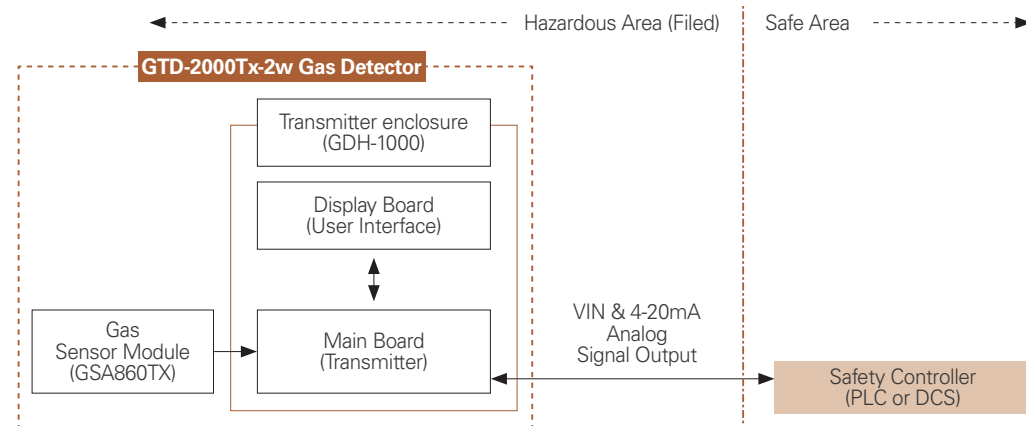

[Figure 1. GTD-2000Tx(2W) Overview]

### 3.1. Basic Specifications

ITEMS	SPECIFICATION	
Measuring Type	Diffusion	
Measuring Value Display	Local Digital LCD Display	
Measuring Method	Electrochemical Cell	
Detectible Gas	Toxic Gas (Note 1)	
Measuring Range	000.0 ~ 9999 (Note1)	
Accuracy	≤ ±3% / Full Range	
Zero Drift	≤ 2% / Full Range	
Response Time	Depends on Sensor Module. Refer to Sensor Specification or Contact in case for Special Gas.	
Approvals Classification	KCs: Ex d IIC T6	
Basic Interface	Analog 4-20mA current interface	
Option	Rain Cover	
Warranty	Transmitter	2 Year
	Sensor	1 Year

※ Note1. Refer to the measured gas list for measured gases and their ranges. Contact us for special gas.

### 3.2. Mechanical Specifications

ITEMS	SPECIFICATION	
Explosion-Proof Type	Explosion-Proof Enclosure	
Dimension	136(W) × 166(H) × 95(D) mm	
Weight including Sensor	App. 1.5kg	
Mounting Type	Wall mount	
Mounting Hole	Ø 7 ±0.1	
Cable Inlet	3/4" PF ( 1/2" or 3/4" NPT )	
Body material	Transmitter	Aluminum Alloy
	Sensor	Stainless Steel (STS316)

3.3. Electrical Specifications (Standard Type)

ITEMS	SPECIFICATION	
Input Voltage(Standard) ※ Customer supplied PSU must meet requirements IEC1010-1 and CE Marking requirements.	Absolute min: Nominal: Absolute max: Ripple maximum allowed:	16V 24V 31V 1V pk-pk
Wattage	Max. wattage: Max. current:	0.5W @+24 VDC 22mA @+24 VDC
Analog output Current	0-20 mA (500 ohms max load) All readings ± 0.2mA Measured-value signal: 4mA(Zero) to 20mA(Full Scale)	
	Fault: 0-100% LEL: 100-109%LEL: Over 110% LEL: Maintenance:	3mA 4mA - 20mA 21.6mA 20mA - 21.4mA 3.5mA
Analog output current ripple & noise max	±20uA	
Wiring requirement	Power	CVVS or CVVSB with shield
Cable Connection Length	Analog	2500m
EMC Protection:	Complies with EN50270	

3.4. Environmental Specifications

ITEMS	SPECIFICATION	
Operation Temperature	Transmitter	-40 to 80 °C
	Sensor	Refer to Sensor Specification
Storage Temperature	Transmitter	-40 to 80 °C
	Sensor	Refer to Sensor Specification
Operation Humidity	Transmitter	5 to 99% RH (Non-condensing)
	Sensor	Refer to Sensor Specification
Pressure Range	90 to 110KPa	
Max. air velocity	6m/s	

4.1. Components

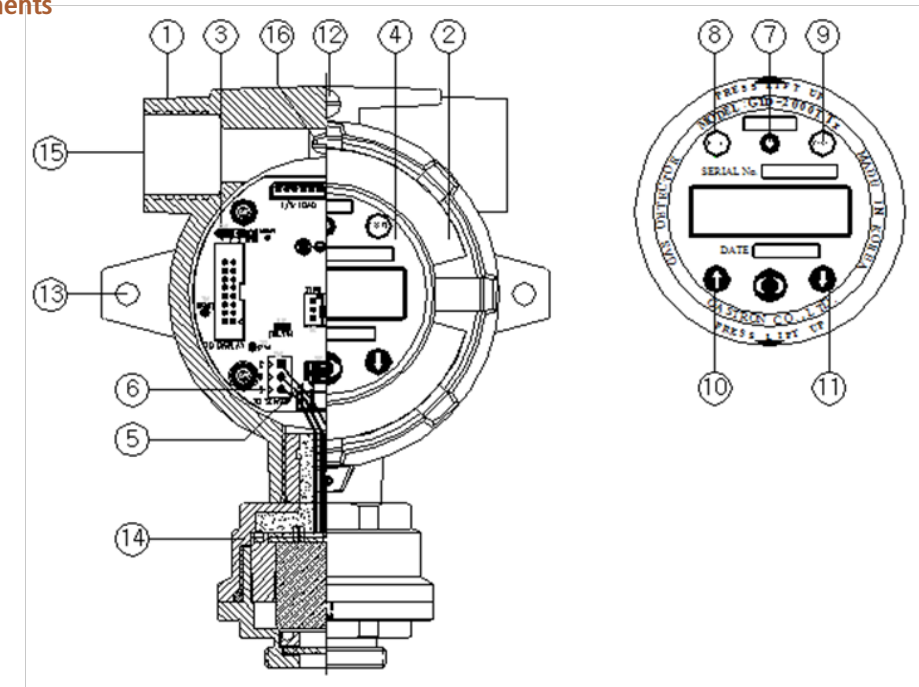

[Figure 2. GTD-2000Tx(2W) Components]

No	ITEMS	SPECIFICATION
1	Detector Housing Body	Protects PCB Board built in Sensor and Housing from external environmental change and shock.
2	Detector Housing Cover	It is assembled with Detector Housing Body. Top surface is built with circular glass to enable monitoring of measurement displayed on LCD.
3	AMP PCB	Amplifies fine outputs generated from Sensor Element to transmit a converted output in 4~20 mA DC standard. It sends data to display part.
4	Display PCB	Displays data sent from Main (Terminal) Transmitter PCB on LCD and displays power status with a power lamp.
5	DIP Switch	DIP Switch (SW1) is set based on Sensor type.
6	Sensor Terminal	CN5 is Sensor Connection Terminal. (Blue, Red, White)
7	Power LED	Lamp lights on when power is supplied.
8	Function Key	Used during Parameter setting to enter the Program by contacting a magnet bar for 2 s and longer. Used to enter data for setting.

No	ITEMS	SPECIFICATION
9	Reset Key	To cancel or return to the previous status during Parameter setting, use the Magnet-Bar and touch once. Each touch returns to the previous status by one unit.
10	(↑) Key	During conversion of mode or number, use the Magnet-Bar and touch once. Each touch converts or increases displayed value by one unit.
11	(↓) Key	During conversion of mode or number, use the Magnet-Bar and touch once. Each touch converts or decreases displayed value by one unit.
12	External Ground	It must be grounded to outside of detector for protection from external noise or strong electric field.
13	Mount Hole (ø7×2ea)	Hole to fix the gas detector on external wall or other installation sites.
14	Sensor	It is a site that detects actual gas leak. It converts the amount of gas leak into electrical signal and transmits to the Main PCB.
15	Conduit Connection	It is supplied during installation work to supply power to detector part and inlet of measured output signal. 3/4" or 1/2" PF, NPT is prepared for cable inlet. (Default is PF 3/4")
16	Internal Ground	It must be grounded to inside of detector for protection from external noise or strong electric field.

[Table 1. GTD-2000Tx(2W) Description of Components]

It is prohibited for an individual, other than an approved user or a technician responsible for installation and repair from the head office, to install a gas leak detector on site or open the cover of the installed gas leak detector and manipulate it. This may cause serious loss of life and property from fire, explosion, and etc. In addition, please check whether there is any remaining explosive gas or combustible material in the surroundings. Power must be turned off before performing work.

### 5.1. Detachment of Housing Cover

- <Warning - Do not open when electrical current is flowing>
- Turn the slotted set screw (M4 x 1ea) fixing the cover part of main body 3~4 turns counter clockwise (ccw) using a hex wrench (M2) then turn the cover of gas leak detector ccw to detach the cover.  
When the cover is detached, LCD appears.

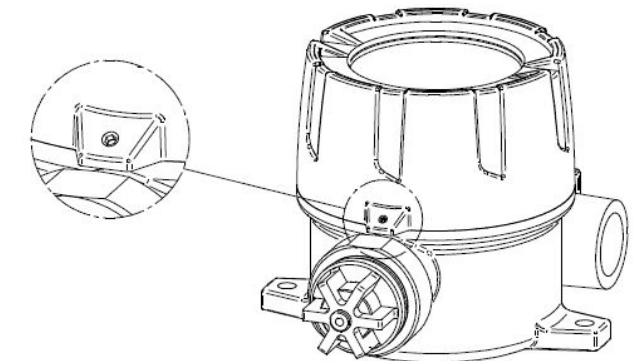

[Figure 3. Slotted Set Screw]

- After detaching the cover, disassemble the display parts as below.
  - ① Push in left and right fixing rings located on front side of LCD at the same time.
  - ② While pushing, pull the display parts towards the front to detach from gas detector body.
  - ③ After detaching the display parts, the Main PCB is installed at the bottom part of the detector body.

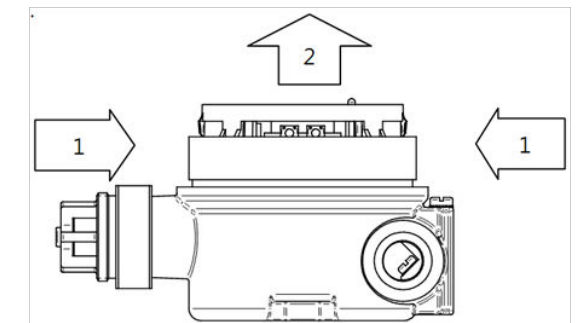

[Figure 4. Method to detach Display Part]



5.2. Main PCB Configuration

■ After detaching the cover, the Main PCB terminal layout appears as shown in the figure below.

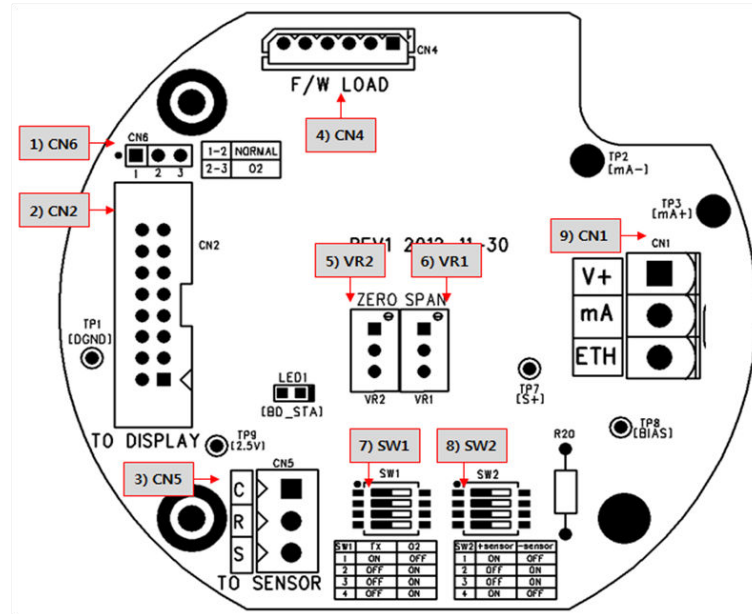

[Figure 5. Main PCB Key Layout]

No	NAME	DESCRIPTION
1	CN6	Program download Connector
2	CN2	Display Module Connector for Status Display
3	CN5	Sensor Connector
4	CN4	Program download Connector
5	VR2	Potentiometer to control ZERO output (Factory Setting)
6	VR1	Potentiometer to control SPAN output (Factory Setting)
7	SW1	Sensor Configuration Switch1 (Factory Setting)
8	SW2	Sensor Configuration Switch2 (Factory Setting)
9	CN1	Power & Output Signal Terminal

[Table 2. Main PCB Key Part Description]

5.3. Power and Signal Terminal Configuration

- <Warning - Turn off power before connecting power terminal>
- After disassembling display parts, there is a terminal block in the Main PCB as shown in the figure below. Holding it with hands and pulling towards ceiling detaches it from the Main PCB.
- Loosen 5 terminal fixing screws located at top part of detached terminal block CN8 (VIS, +, mA, -, ETH) Connector by turning ccw using a  $\Theta$  driver. Connect DC 18~24 V power to +, and - then connect signal cable to mA. Tighten 5 terminal fixing screws clockwise (cw) so that terminal does not leave the track then insert Main PCB as the same condition before disassembly.

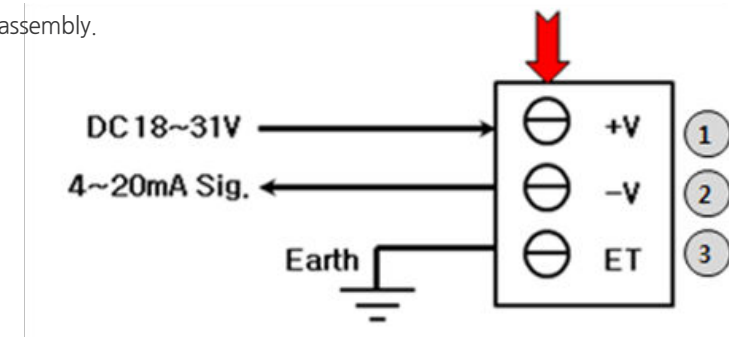

[Figure 6. CN1 Terminal Configuration]

NO	PIN NAME	DESCRIPTION
1	+V	+24V / POWER (+)
2	-V	4~20mA Source Out
3	ET	EARTH

[Table 3. CN1 Terminal Detailed Description]

- Use CVVS or CVWSB 2.0sq $\uparrow$  Shield Cable for terminal configuration.

5.4. Method to Connect to External Control Unit

- Connect 18 V~31 V DC operation power to CN1 (+, mA, -, ET) Connection Terminal of the gas detector then connect a device that can receive 4~20 mA signals to mA.

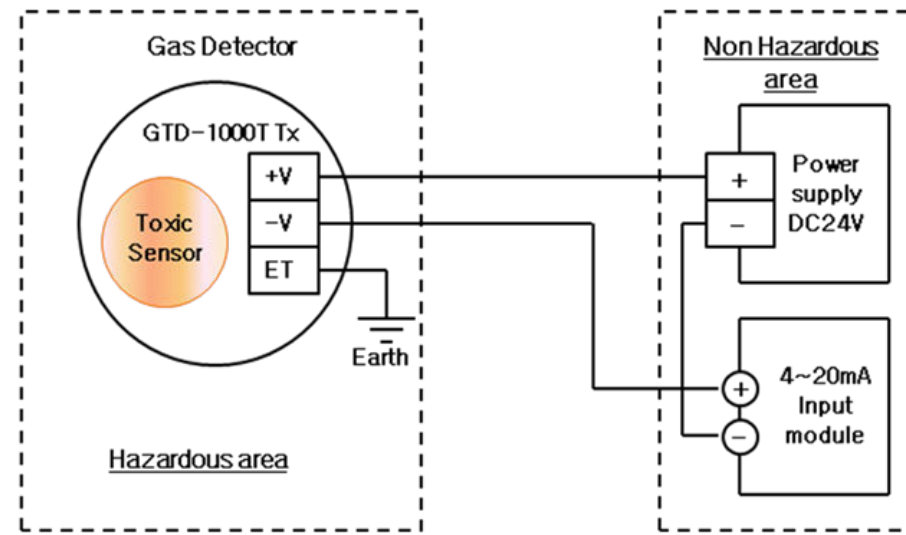

[Figure 7. Method to connect External Control Unit]

5.5. Installation Cable Length

- The maximum length between GTD-2000Tx(2W) and power supply is decided by wire specification.
- Max. Installation Length =  $V_{MAXDROP} \div I_{MAX} \div WIRER/m \div 2$ 
  - VMAXDROP: Maximum Power Loop Voltage Drop (=Power Supply voltage - min operating voltage)
  - IMAX : Max. Current of GTD-2000Tx(2W)
  - WIRER/m: The resistance of the wire (ohms/meter value available in wire manufacturer's specification data sheet)
- Example of installation lengths using 24 V power supply and 16 AWG is as follows.
  - GTD-2000Tx(2W) minimum operating voltage = 16 V DC
  - VMAXDROP = 24 - 16 - 5.5 = 2.5V
  - IMAX = 0.022A ( 22mA )
  - $2.5 \div 0.022 \div 0.01318 \div 2 = 4,310.9 \text{ m} \approx 4310 \text{ m}$

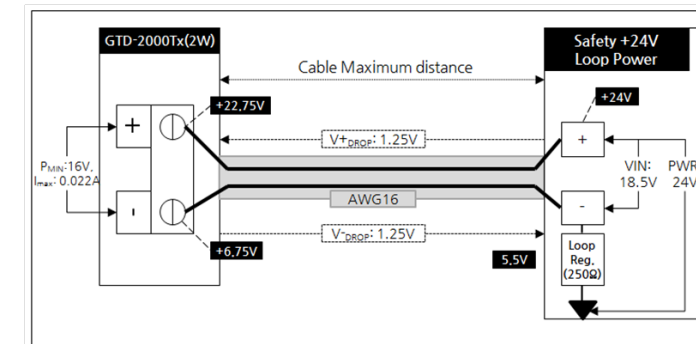

[Figure 7. Calculation of GTD-2000Tx(2W) Installation Cable Length]

- Power cable installation for each cable type is as shown in the table below.



AWG	mm2	COPPER RESISTANCE(ohms/m)	METERS
12	3.31	0.00521	10905
14	2.08	0.00828	6862
16	1.31	0.01318	4310
18	0.82	0.02095	2712
20	0.518	0.0333	1706

[Table 4. GTD-2000Tx(2W) Power Cable Installation Length]





### 6.1. Initial Operation Status (Power On)

- After wiring to power terminal at the top of Main PCB board then supply power, the following contents are displayed on LCD. Approx. 30 min of stabilization of time is needed from the initial supply of operation power and it starts to operate normally after sufficient stabilization.

	- Displays Program Version
	- After running "SELF TEST" for 30 sec then converts to Measuring Mode. - During "SELF TEST", status LED blinks on the Main Board. After completion of "SELF TEST", status LED lights on. - However, when Membrapor O2 is used, "SELF TEST" persists until the sensor stabilizes. Contacting "RESET" key returns to Measuring Mode.



### 6.2. Measuring Mode

- After power on, when there is no error from "SELF TEST", it automatically enters Measuring Mode.

	- Displays the current measurement.
	- When a value equal or greater than 10% of High Scale value is inputted, "OUr(over)" is displayed on LCD.
	- When %LEL value below zero is equal or less than -10%, "Und(under)" is displayed on LCD. (Optional - Refer to Page 20)

### 6.3. Operation Flow

- After power on, it passes self-diagnostic process then enters Measuring Mode. Here, by operating front keys, you can go to internal System Mode.
- Timeout for Level1 and Level2 are 10 sec. It is set to 1 h for Level2 Calibration and Test Mode.
- When "RESET" key contacts at Program Mode Screen, it returns to Measuring Mode. When "RESET" key contacts at each Program Setting Screen, it returns to the parent step.

LEVEL1	LEVEL2		DEFAULT
	NAME	PARAMETER	
Program Mode 	<i>d-P</i> (Decimal-Point)	100,10.0,1.00,0.100	100
	<i>HSL</i> (High-Scale)	1~1999	100
	<i>GFt</i> (Gas Function Type)	Ty1,Ty2,Ty3,Ty4	Ty1
	<i>PRs</i> (Pass-Word)	0~99	--
	<i>UEr</i> (Version)	XXX	XXX
	<i>End</i> (End)	-	-
Calibration Mode 	<i>2-C</i> (Zero-Calibration)	NO , YES	NO
	<i>0</i> ( 0 )	-	-
	<i>9od</i> (Good)	-	-
	<i>0</i> ( 0 )	-	-
	<i>5-C</i> (Span-Calibration)	NO , YES	NO
	<i>50</i> ( 50 )	-	-
Sensor Mode	Factory Mode		
Option Mode	Factory Mode		
System Mode	Factory Mode		

### 7.1. PROGRAM MODE

<b>PASSWORD [**]</b>	- Contacting "FUNC" key with the Magnet-bar for 2 sec or longer in Measuring Mode enters Password mode. - After setting Password using "↑" or "↓" key, contact "FUNC" key.
<b>PROGRAM MODE</b>	- If password is correct, it enters Program mode. - By contacting "↑" or "↓" key, mode changes in defined order. ( PROGRAM -> CALIABRA. -> ALARM -> SENSOR -> MAINTEN. -> DEVICE -> VERSION -> TEST )
<b>GAS TYPE [DEFIN, ]</b>	- Mode that sets gas name type and contacting "↑" or "↓" key changes gas type. (DEFIN. / USER) - DEFIN. Is acronym for Define and is selected when using built-in setting of gas name. - USER is selected when the user directly sets a gas name. - When a desired gas type is displayed, contact "FUNC" key to set the gas name and enter Program Mode.
<b>GAS SEL [COMB. ]</b>	- Mode that sets gas name and contacting "↑" or "↓" key changes gas name. - When gas type is set to DEFIN., built-in gas names can be selected for use. When it is set to USER, the user shall set gas name using 5 character for use. Characters allowed for use are number, capital Alphabet, space, and period. When position is moved by setting characters, a cursor in black box shape appears as shown in the figure on left.
<b>USER GAS [SER ]</b>	
<b>UNIT SEL [%LEL ]</b>	- Mode that sets gas measuring unit and contacting "↑" or "↓" key changes gas measuring unit. ( % / %LEL / PPM / PPB ). - When a desired gas measuring unit is displayed, contact "FUNC" key to set the unit and enter Program Mode.
<b>D-POINT [ 100]</b>	- Mode that changes decimal place and contacting "↑" or "↓" key changes decimal place. (0.100/1.00/10.0/100) - When a desired decimal place is displayed, contact "FUNC" key to set the decimal place and enter the next Program Mode.
<b>HIGH SCL [ 100]</b>	- Mode that sets high scale value that should be displayed for full range. Contacting "↑" or "↓" key increases or decreases the scale value. (1 ~ 10000) - When a desired high scale is displayed, contact "FUNC" key to set the high scale value and enter the next Program Mode.
<b>PASSWORD [00]</b>	- It is password setting mode. This password is checked when entering Program Mode. - Set using "↑" or "↓" key then contact "FUNC" key to set the password and enter the next Program Mode.

### 7.2. CALIBRATION MODE

- Due to characteristics of the gas detector, minimum 30min of stabilization time is required and maintenance condition may change depending on site condition.

	- Contacting "FUNC" key with the Magnet-bar for 2 sec or longer in Measuring Mode enters Password mode. - Enter a 2-digit password using "↑" or "↓" key then contact "FUNC" key to enter Program Mode.
	- Contact "↑" or "↓" key to select "Calibration Mode".
	- Contact "FUNC" key when "CAL" is displayed to enter Calibration Mode. - Contact "RESET" key to return to Measuring Mode.
	- Contact "↑" or "↓" key to achieve Z-C (Zero-Calibration) then contact "FUNC" key to enter the next step.
	- Contact "↑" or "↓" key to achieve [YES] then contact "FUNC" key to enter Zero Calibration. (Default "no")
	- Mode that performs Zero Calibration and measurement is displayed. - Using a calibration tool, inject clean air or 100% nitrogen into the sensor at a flow rate of 500 mL/min for 1 min. Contact "FUNC" key when measurement is stabilized to automatically perform Zero Calibration.
	- When zero calibration is successful, "god (good)" is displayed on LCD display for 2 sec.
	- When zero calibration is not successful, "FAI (Fail)" is displayed for 2 sec and it changes to "Calibration Data". - Contact "RESET" key to return to "Calibration".
	- It is a mode to display measurement after calibration and checks whether calibration is successful after performing auto calibration. - Contacting "FUNC" key returns to "Calibration Mode".
	- Contact "↑" or "↓" key to achieve S-C (Span-Calibration) then contact "FUNC" key to enter the next step
	- Contact "↑" or "↓" key to achieve [YES] then contact "FUNC" key to enter Span Calibration. (Default "no")
	- Using a calibration tool, inject standard gas to the sensor. When it is stabilized, contact "FUNC" key.
	- Using "↑" or "↓" key, set standard gas value then contact "FUNC" key.

9od	- When span calibration is successful, "god (good)" is displayed on LCD display for 2 sec.
FAI	- When span calibration is not successful, "FAI (Fail)" is displayed for 2 sec and it changes to "Calibration Data Mode". - Contact "RESET" key to return to "Calibration Mode".
50	- It is a mode to display measurement after calibration and checks whether calibration is successful after performing auto calibration. - Contacting "FUNC" key returns to "Calibration Mode".

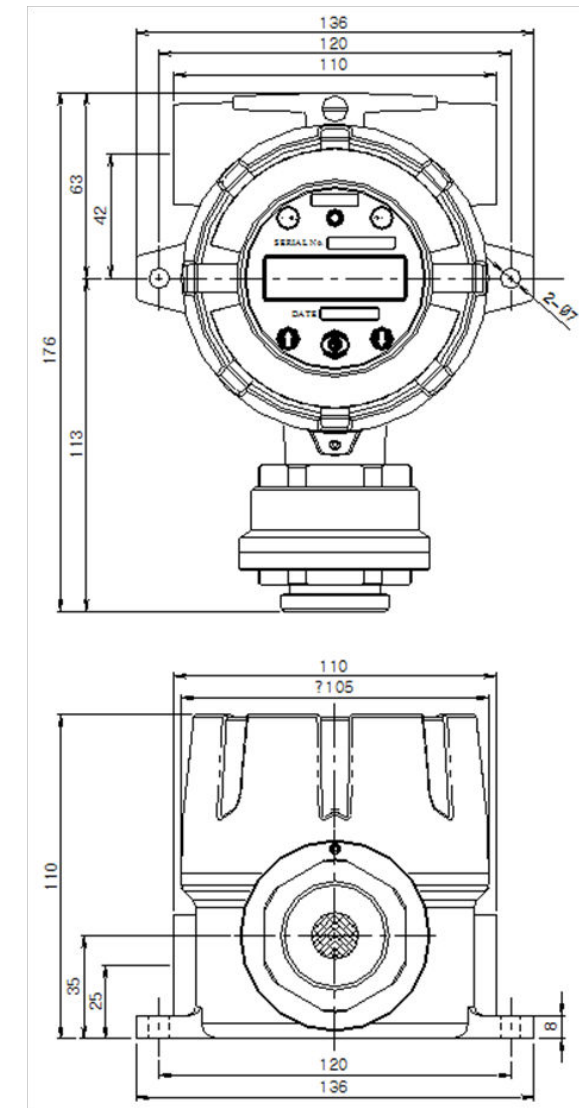

[Figure 8. GTD-2000Tx(2W) Drawing]

### 9.1. Selecting a Place for Installation (Occupational Health & Safety Act Data)

A gas leak detector alarm shall be installed in the following places.

- Around chemical equipment and accessories that have concerns of gas leak. This includes compressors, valves, reactors, pipe joints, etc. installed inside and outside of a building that handle combustible and toxic materials.
- Places that are easier for gases to stay such as areas around manufacturing facilities with ignition sources like heating furnace, etc,
- Areas around equipment for filling combustible and toxic materials.
- Substations, panel rooms, control rooms, and etc. located within explosive area.
- Other areas that are easier for gases to stay.

### 9.2. Selecting a Site for Installation (High-Pressure Gas Safety Control Act Data)

Gas detector of gas leak detector alarm must be installed as close to the areas with concerns of gas leakage as possible. However, for areas where direct gas leakage is not expected but are easier for leaked gas to stay, the detector must be installed at the point 1 of the following.

- Gas leak detector alarm installed outside a building shall be installed at points where gas is likely to stay in consideration to wind direction, wind speed, specific gravity of gas, etc.
- Gas leak detector alarm installed inside a building shall be installed near the floor when the specific gravity of gas is heavier than air and near ventilation of ceiling when it is lighter than air.
- Alarm for gas leak detector alarm must be installed at sites where the gas detector is installed and workers are present.

### 9.3. Precautions during Installation

Avoid areas with electrical barriers such as rain water, etc. It is recommended to be installed in areas that are easier to work in since regular maintenance is needed. Avoid areas with vibration or shock since they can affect output values. Sensor part must be installed towards the direction of gravity.

- This equipment has explosion-proof construction for internal pressure and belongs to GROUP II for gas and vapor in general work sites and chemical plants. It can be used in ZONE 1 (ONE) and ZONE 2 (TWO) hazardous sites.
- Allowable temperature is 85 C or below, which corresponds to T6.
- Surrounding temperature shall be in a range of -40 to 80 °C (for Main body. For sensor, refer to each sensor manual.)
- Installation Height: 1,000 M below sea level
- Relative Humidity: 5% ~ 99% (Non-condensing)
- Installation Site: Indoor and Outdoor
- Explosion Ignition Group for Target Gas or Vapor: Ex d IIC T6

- During wiring work, use explosion-proof cable gland at cable inlet or tightly seal cable conduit during metal cable wiring construction to prevent spread of flames in case of explosion or movement of gas, etc. through the cable conduit within 50 mm. All materials including materials used for sealing of unused inlets must have safety certificates!
- When connecting the equipment with cable, screw thread must be tightened 5 threads or more.
- Work in conditions satisfying other [Standards for Selection, Installation, and Maintenance, etc. of Explosion-proof Electric Machine and Equipment Wiring, etc. at Work Site]
- All materials used for cable inlet such as cable gland and sealing fitting, etc. and used as sealing unused inlets must pass the verification!

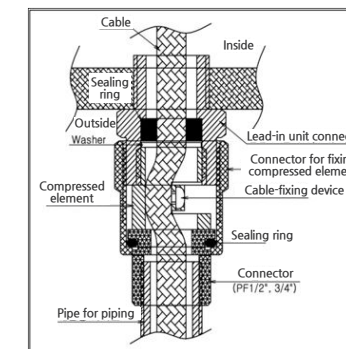

[Figure 9. High-Pressure Packing Type]

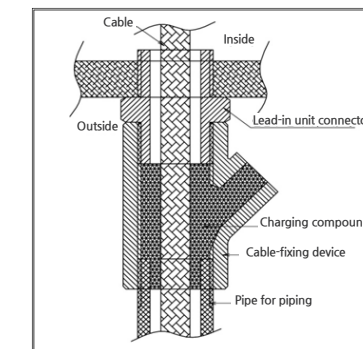

[Figure 10. Y Sealing Compound]

VERSION	CONTENTS	DATE
0.0	* Manual Initial Revision	2012.04.17
1.0	* Corrected Typos	2012.04.20
2.0	* Changed consumed current	2013.01.21
3.0	* Changed Font	2013.02.21
4.0	* Added Program Mode Function.	2014.06.08
5.0	* Added O2 function	2014.10.24
6.0	* Separated Factory mode manual	2016.09.28
7.0	* Changed Explosion-proof Equipment Cable Entry Installation Regulation 45 cm → 50 mm	2017.01.20