

GTD-3000Tx Intelligent Diffusion Oxygen & Toxic Gas Detector

| Continuous detection of toxic gases and oxygen in explosion hazardous area with flame proof structure | Self diagnosis function with built-in Microprocessor | Excellent selectivity by adapting detection principle only for toxic gases & oxygen | Stable quality and proved detection principle for service life | Built-in back light LCD or OLED display | Auto calibration and program setting with a magnet bar | 2-stage alarm, 1-trouble display and relay contact output | 4-20mA (Current source or Sink) output signal | Easy configuration of monitoring system by RS-485 Modbus communication | With the alarm unit - Normal : Green LED -Alarm : Red LED, Buzzer(95 dB) -Trouble : Yellow LED | Calibration and maintenance by one-man | Superior performance for detecting gases below TLV |

IMAGE



DIMENSION (Unit : mm)

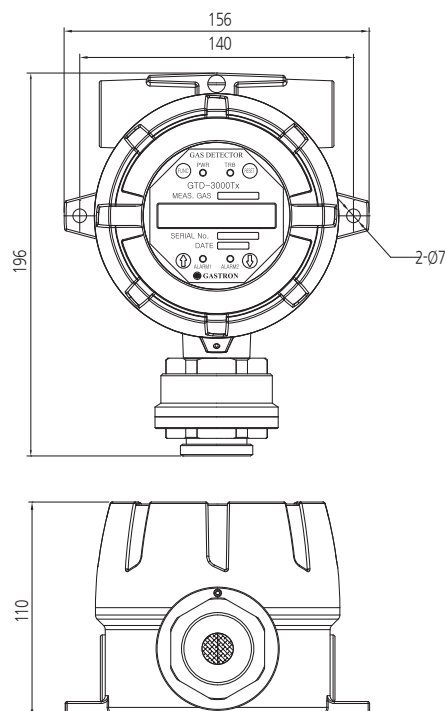

ACCESSORIES



Cable Gland

GTL-100

Rain cover

Splash guard

Collecting-cone

RS-485 module

SPECIFICATION

※ Specifications are subject to be changed without prior notice.

INTELLIGENT & LOCAL DISPLAY TYPE OXYGEN & TOXIC GAS DETECTOR	
Model	GTD-3000Tx
Measuring gas	O ₂ Toxic gases(CO, Cl ₂ , NH ₃ & etc)
Measuring type	Diffusion type
Measuring method	Galvanic cell or Electrochemical cell Electrochemical cell
Measuring range	Refer to Toxic Gas Measuring Range
Response time	< 15sec / 90% scale < 45sec / 90% scale
Accuracy	±3% / Full scale
Parameter control	Non intrusive control with a Magnet (calibration, maintenance, alarm setting)
Operation mode display	4-LED (Power, 2-stage alarm, 1-trouble)
Measuring value display	LCD display (Built in back light 2-Line, 16 characters) / OLED Type (Option)
Alarm signal output	2A@30VDC, 0.5A@125VAC (resistive load) / 3-SPST relay contact(2stage alarm, 1 trouble)
Output signal	Analog : Measuring signal : 4-20mA DC Fault signal : 0mA DC Digital : Calibration signal : 3mA DC
Conduit connection	Standard : PF 3/4" Option : NPT 1/2", N , M25 x 1.5P
Mounting type	2" Pole mount, Wall mount, Duct mount
Operating temperature	-20°C ~ +60°C
Operating humidity	5 ~ 99%.RH (non-condensing)
Dimensions	156(W) x 196(H) x 110(D)mm
Weight	2.0kg
CERTIFICATION	
KCs	Ex d IIC T6 NEPSI Ex d IIC T6 Gb
CE / KC / CPA	Refer to website