



Headquarters / Engineering research laboratory :
23 Gunpo Advanced Industry 1-ro(Bugok-dong), Gunpo-si, Gyeonggi-do
Tel +82-31-490-0800 Fax +82-31-490-0801

Yeongnam business office / Plant :
55 Gonghangap-gil 85beon-gil, Gangseogu, Busan Metropolitan City
Tel +51-973-8518 Fax +51-973-8519

E-mail : info@gastron.com

www.gastron.com

GTD-3000Tx

Instruction Manual



Read in detail for correct use.

Gas & Flame Detection System

GASTRON



When abnormalities occur after purchasing the product,
please contact the following address.

- Address : 23 Gunpo Advanced Industry 1-ro,
Gunpo-si, Gyeonggi-do
- Tel : 031-490-0800
- Fax : 031-490-0801
- URL : www.gastron.com
- e-mail : info@gastron.com

We sincerely thank you for purchasing the product of Gastron Co. Ltd.

Our Gastron Co.Ltd. is a company specialized in Gas detector and Gas Monitoring System, being recognized by many consumers due to the best quality and use convenience. We always enable you consumers to find desired products nearby and are ceaselessly studying and striving for development of Gas detectors satisfying customers. From now on, solve all anguishes concerning Gas detector with the products of Gastron Co. Ltd, We Gastron Co. will take a responsibility and give you satisfaction.

In the present instruction manual, operation method for Gas detector as well as simple methods for maintenance and repair, etc. are recorded. If you read it in detail and keep it well, for reference when you have questions, then it will give you much help.

- For accurate operation of Gas detector, check up and calibrate for more than once in every 6 months.
(* See No. 13 of KOSHA GUIDE : P-135-2013 / 8.3 paragraph on qualification and calibration)
- For accurate operation of Gas detector, checkup and calibration with calibration gas before measurement is recommended.
- When not calibrated, it may cause malfunction of the equipment due to problems resulting from Sensor aging.
- When the present instrument should be dismantled, those with professional skills for Gas detector should conduct the operation.
- For power supply cable, wire specifications should be determined by referring to the item of "Length of installed cable".
- For the contents on checkup and calibration of Gas detector, please use our company's engineering department , e-mail, or web site.

The present product and the product manual can be changed without advance notice for performance improvement and use convenience of the product.

* KOSHA GUIDE : P-135/6-2018

Calibration should be executed at the periods required by the manufacturer, and should be executed every quarter unless there are separate calibration periods.

1. Overview	6	7. System Mode	22
2. Configuration	6	7.1. PROGRAM MODE	22
3. Specification	7	7.2. CALIBRATION MODE	23
3.1. Basic Specifications	7	7.2.1. Zero Calibration	23
3.2. Mechanical Specifications	7	7.2.2. Span Calibration	24
3.3. Electrical Specifications (Standard Type)	8	7.3. ALARM Mode	25
3.4. Environmental Specifications	8	8. Troubleshooting	27
4. Name and Description of Each Part	9	8.1. Fault List	27
4.1. Components	9	8.2. Recovery List	27
5. Installation	11	9. Interface Configuration	28
5.1. Detachment of Housing Cover	11	9.1. MODBUS RS485	28
5.2. Main PCB Configuration	12	9.1.1. Interface setting	28
5.3. Power & 4-20 mA Terminal Configuration	13	9.1.2. MODBUS RS485 Register map	28
5.3.1. Wiring for 4~20mA Source Operation Type	14	10. Drawings and Dimensions	29
5.3.2. Wiring for 4~20mA Sink Operation Type	14	10.1. Standard Type	29
5.3.3. Wiring for 4~20mA 3Wire Sink Operation Type	15	10.2. For Warning Light Assembly	30
5.4. Relay and Network Terminal Configuration	15	10.3. During Rain Cover Assembly	31
5.4.1. Terminal Configuration	15	11. Precautions before Installation	32
5.4.2. Relay Mode Configuration	16	11.1. Selecting a Place for Installation (Occupation Safety and Health Act Data)	32
5.4.3. RS485 MODBUS Setting	16	11.2. Selecting a Site for Installation (High-Pressure Gas Safety Control Act Data)	32
5.5. Installation Cable Length	17	11.3. Precautions during Install	32
6. Detector Operation Flow	18	12. Revision History	34
6.1. Initial Operation Status (Power On)	18		
6.2. Measuring Mode	18		
6.3. Operation Flow	19		
6.4. Menu Configuration Table	20		

GTD-3000Tx toxic gas detector has been developed to detect gas leaked from industrial sites and various flammable gases generated from factories, gas storages, and manufacturing processes that produce or use toxic gases and to prevent accidents in advance. GTD-3000Tx toxic gas detector is installed in areas with gas leak hazards and continuously monitors gas leak. It displays measurements on built-in displays (LCD) of the detector and provides Analog 4~20 mA standard output signal. Also, for Analog 4~20 mA standard output, output signal transmission length between detector and receiver can be connected up to 2,500 m. (When Cable CVVS or CVVSB 1.5sq and higher is used.) GTD-3000Tx toxic gas detector must be used at a height below 1,000 m above sea level.

2. Configuration

Body of GTD-3000Tx is made of Aluminum alloy and the gas sensor module is made of stainless steel. It consists of a complete explosion-proof enclosure (Ex d IIC T6). This product can be installed in areas with toxic gas leak and explosion hazards. It has built-in LCD on the detector to display gas leak status at installed site. Internal configuration consists of display part that indicates measurements, terminal part that output measurements (Analog 4~20mA) externally, and a PCB board. External configuration consists of detector part that monitors gas leak and cable inlets. It uses magnet-bar outside the main body of detector enabling calibration from the outside of the detector, thus, maintenance is convenient.

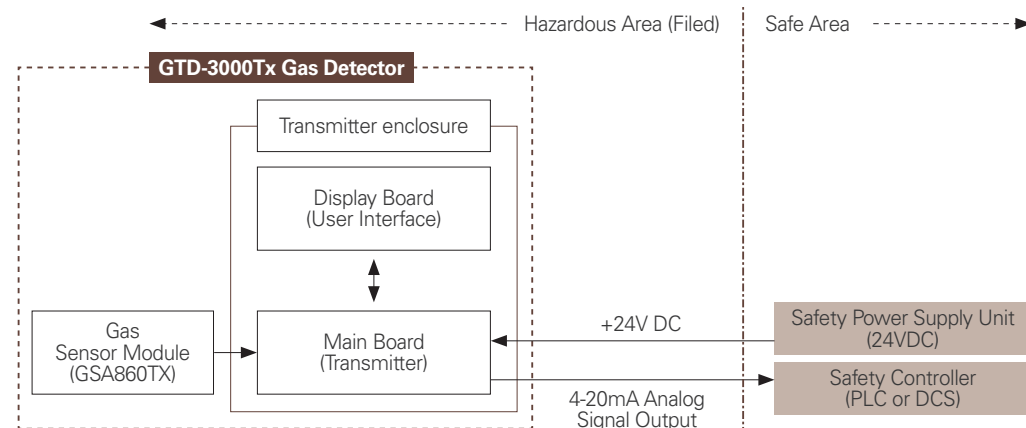

[Figure 1. GTD-3000Tx Overview]

3.1. Basic Specifications

ITEMS	SPECIFICATION	
Measuring Type	Diffusion	
Measuring Value Display	LCD or OLED Display	
Measuring Method	- Electro-Chemical Cell - Heated-semiconductor Cell	
Detectible Gas	Toxic Gas (Note1)	
Measuring Range	Capable to display 000.0 ~ 9999 (Note 1)	
Accuracy	≤ ±3% / Full Range	
Zero Drift	≤ 2% / Full Range	
Response Time	Depends on Sensor Module. Refer to Sensor Specification or Contact in case for Special Gas.	
Approvals Classification	KCs: Ex d IIC T6, T5, T4, IP65	
Basic Interface	Analog 4-20mA current interface	
HART Interface	HART REV7 (Option)	
Option	HART Board	
	MODBUS RS485 Board	
	GTL-100 Warning Light	
	Rain Cover	
Warranty	Transmitter	2Year
	Sensor	1Year

※ Note1. Refer to the measured gas list for measured gases and their ranges. Contact us for special gas.

3.2. Mechanical Specifications

ITEMS	SPECIFICATION	
explosion Proof type	Explosion-proof enclosure	
Dimension	156(W) × 322(H) × 110(D) mm	
Weight including Sensor	App. 1.8kg	
Mounting type	Wall mount	
Mounting Holes	∅ 7 ±0.1	
Cable inlet	3/4" PF (1/2" or 3/4" NPT)	
Body material	Transmitter)	aluminum alloy
	Sensor	Stainless Steel (STS316)

3.3. Electrical Specifications (Standard Type)

ITEMS	SPECIFICATION	
Input Voltage(Standard) ※ Customer supplied PSU must meet requirements IEC1010-1 and CE Marking requirements.	Absolute min: Nominal: Absolute max: Ripple maximum allowed:	18V 24V 31V 1V pk-pk
Wattage	Max. wattage: Max. current:	3.6W @+24 VDC 150mA @+24 VDC
Analog output Current	0-20mA(500 ohms max load) All readings ± 0.2mA Measured-value signal: 4mA(Zero) to 20mA(Full Scale)	
	Fault: 0-100% LEL: 100-109%LEL: Over 110% LEL: Maintenance:	0mA 4mA - 20mA 20mA - 21.4mA 22mA 3mA
Analog output current ripple & noise max	±20uA	
Relay contact	Alarm1, Alarm2, Fault Relay Rated 1.0 A @ 30VDC or 0.5 A @ 125 VAC	
Wiring requirement	Power	CVVS or CVVSB with shield
	Analog	CVVS or CVVSB with shield
	RS485	STP(Shielded Twisted Pair)
Cable Connection Length	Analog	2500m
	RS485	1000m
EMC Protection:	Complies with EN50270	

3.4. Environmental Specifications

ITEMS	SPECIFICATION	
Operation Temperature	Transmitter	-20 to 60 °C
	Sensor	Refer to Sensor Specification
Storage Temperature	Transmitter	-20 to 60 °C
	Sensor	Refer to Sensor Specification
Operation Humidity	Transmitter	5 to 99% RH (Non-condensing)
	Sensor	Refer to Sensor Specification
Pressure Range	90 to 110KPa	
Max. air velocity	6m/s	

4.1. Components

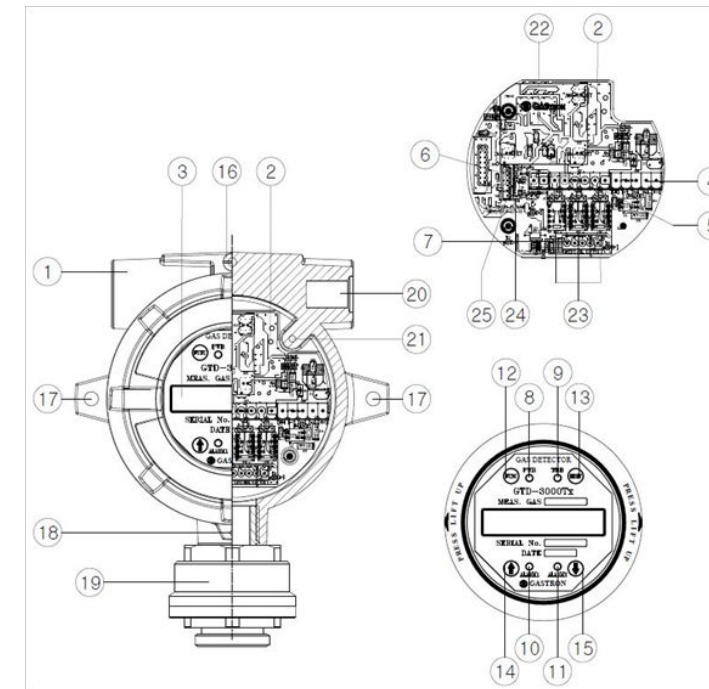

[Figure 2. GTD-3000Tx Components]

NO	NAME	DESCRIPTIONS
1	Housing	Protects Sensor and PCB Board built in the Housing from external environmental change and shock.
2	Main PCB	It amplifies output signal from the sensor and converts and send it as Analog 4~20 mA standard output. Isolation RS-485 network and alarm relay contact signals are outputted. Also, it sends data for the display.
3	Display PCB	It displays data received from main PCB on LCD or OLED and displays the current event status with power lamp, alarm lamp, trouble lamp
4	Power/Signal Terminal	CN8 consists DC18-24 V power supply and Analog 4~20 mA standard output connection terminal (VISO, +24V, mA, -, ETH).
5	Alarm signal Terminal	CN7 is alarm signal connection terminal, which outputs trouble, alarm1, alarm2 relay contacts.
6	RS-485 signal	CN6 is Isolation RS-485 network signal connection terminal (A, B).
7	Sensor terminal	CN1 is Sensor Connection Terminal. (WH, RD, BL, GR, BK)
8	Power lamp	When power is turned on, it lights on.
9	Trouble lamp	It lights on when there is a fault in the circuit or sensor sensitivity, etc.

NO	NAME	DESCRIPTIONS
10	Alarm1 lamp	It lights on when gas leaks and it exceeds Alarm1 level.
11	Alarm2 lamp	It lights on when gas leaks and it exceeds Alarm2 level.
12	Function key	During parameter setting, it changes to program mode when it is contacted with magnet-bar for 2 sec or longer. (Program mode, Calibration mode, Test mode, etc.) Also, it is used to enter and set an arbitrary data.
13	Reset key	To cancel or return to the previous status during Parameter setting, use the Magnet Bar and touch once. (Each touch returns to the previous status by one unit.
14	↑(Up) key	During conversion of mode or number, use the Magnet-Bar and touch once. Each touch converts or changes one level. (Converts to the next level)
15	↓(Down) key	During conversion of mode or number, use the Magnet-Bar and touch once. Each touch converts or increases displayed value by one unit. (Converts to the previous level)
16	External earth	- It is an external ground for protection from external noise or strong electric field. - Use a conductor that is 4 mm or longer when coupling ground line.
17	Mount hole	Hole to fix the gas detector on external wall or other installation sites.
18	Cover fixed screw(M4)	After assembling detector housing body and cover, they are fixed with hex lens bolt to prevent detachment by external shock.
19	Sensor thread	It is a mounting for gas sensor (detector).
20	Cable inlet	It is provided to supply power and inlet for measured output signal of the gas detector during installation work. As default, PF 3/4" is provided.
21	Internal earth	- It must be grounded to inside of detector for protection from external noise or strong electric field. - Use a conductor that is 4 mm or longer when coupling ground line.
22	RS-485 Module / HART Module (Option)	It is a connector for Isolation Type RS-485 and HART network modules to communicate with PC or PLC. To run RS-485 network, network address must be configured. Default is 1. To run HART network, Polling-Address and Tag No., etc. must be configured.
23	Relay Contact Type Selection Jumper	It is constructed to select A or B contact. When it is not in ENERGIZER MODE, it operates in A contact (Normal Open) mode or B contact (Normal Close) mode when Jumper is connected to a part marked as A silk or B silk, respectively. In contrast, when it is in ENERGIZER MODE, connecting Jumper to A operates in B contact mode and connecting Jumper to B operates in A contact mode.
24	Warning Light Connector	It is a connector connected when a warning light is used. (Option)
25	Program Connector	It is a connector for downloading the program for the product.

[Table 1. GTD-3000Tx Components Description]

It is prohibited for an individual, other than an approved user or a technician responsible for installation and repair from the head office, to install a gas leak detector on site or open the cover of the installed gas leak detector and manipulate it. This may cause serious loss of life and property from fire, explosion, and etc. In addition, please check whether there is any remaining explosive gas or combustible material in the surroundings. Power must be turned off before performing work.

5.1. Detachment of Housing Cover

- <Warning - Do not open when electrical current is flowing>
- Turn the slotted set screw (M4 x 1ea) fixing the cover part of main body 3~4 turns counter clockwise (ccw) using a hex wrench (M2) then turn the cover of gas leak detector ccw to detach the cover. When the cover is detached, LCD appears.

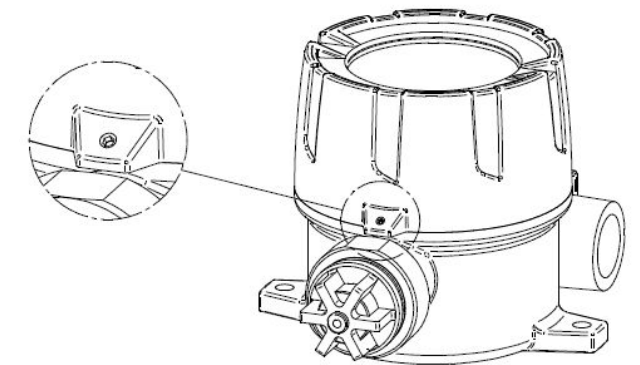

[Figure 3. Slotted Set Screw]

- After detaching the cover, disassemble the display parts as below.
 - ① Push in left and right fixing rings located on front side of LCD at the same time.
 - ② While pushing, pull the display parts towards the front to detach from gas detector body.
 - ③ After detaching the display parts, the Main PCB is installed at the bottom part of the detector body.

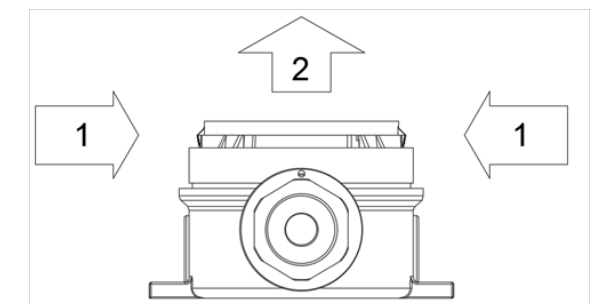

[Figure 4. Display Part Detaching Method]

5.2. Main PCB Configuration

■ After detaching the display parts, the Main PCB terminal layout appears as shown in the figure below.

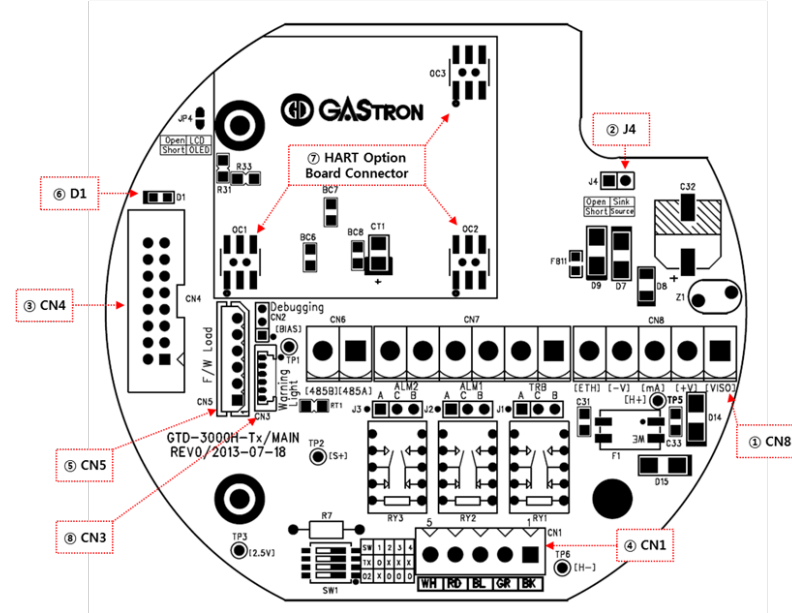

[Figure 5. Main PCB Terminal Layout]

No	NAME	DESCRIPTION
1	CN8	Power & Output Signal Terminal
2	J4	4~20mA Source / Sink Selection Jumper (ON: Source Type, OFF: Sink Type)
3	CN4	Display LCD Connector
4	CN1	Sensor Connector
5	CN5	Program download Connector
6	D1	Status LED (Flashes in 1 sec interval during normal operation)
7	OC1,OC2,OC3	HART Option Board Connector
8	CN3	Warning light (GTL-100) Interface Connector

[Table 2. Main PCB Key Part Description]

■ Using OC1, OC2, and OC3 shown in the layout above, HART Option RS-485 MODBUS board can be attached. 3ØScrew holes located at top left of option board are used for fixing.

5.3. Power and 4-20mA Terminal Configuration

- <Warning - Turn off power before connecting power terminal>
- After detaching the display part, there is a terminal block in the Main PCB as shown in the figure below. Holding it with hands and pulling towards ceiling detaches it from the Main PCB.
- Loosen 5 terminal fixing screws located at top part of detached terminal block CN8 (VISO, +V, mA, -V, ETH) Connector by turning counter-clockwise using a Θ driver. Connect DC 24 V power to +, and - then connect signal cable to mA. Tighten 5 terminal fixing screws clockwise so that terminal does not escape the track then insert Main PCB as the same condition before disassembly.

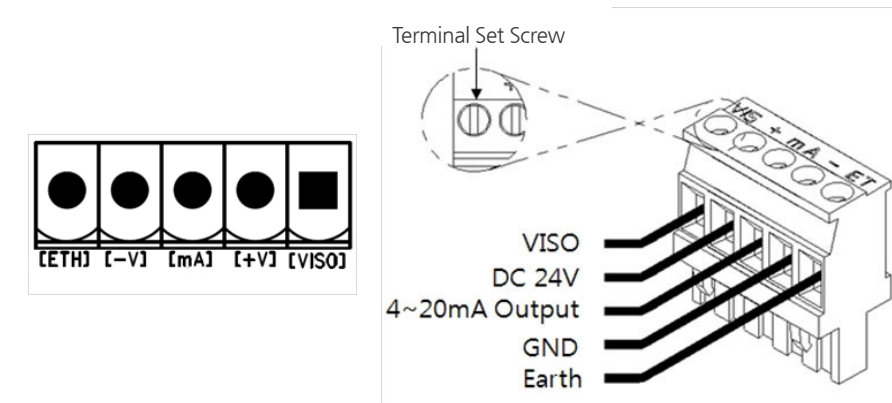

[Figure 6. CN8 Terminal Configuration]

No	PCB Silk	PIN NAME	DESCRIPTION	
			4~20mA Source Drive (J1 Jumper ON)	4~20mA Sink Drive (J1 Jumper OFF)
1	VISO	VIS	N.C	4~20mA Sink In(+)
2	+24V	+	+24V / POWER (+)	
3	mA	mA	4~20mA Source Out	4~20mA Sink Out(-)
4	GND	-	GND / POWER (-)	
5	ETH	ET	EARTH	

[Table 3. CN8 Terminal Detailed Description]

- Use CVVS or CVVSB 2.0sq \uparrow Shield Cable for terminal configuration.
- To connect 4 Pin terminal from the existing old GTD-2000Tx model, connect terminals in reference to pin #2, which is +24V.

5.3.1. Wiring for 4~20mA Source Operation Type

- Connect 4-20 mA signal terminal at PLC side to 'mA' of 3000Tx. GND terminal is used in common with power. Then, turn on the J1 jumper.
- HART Communicator can only be used in models using HART Option board.

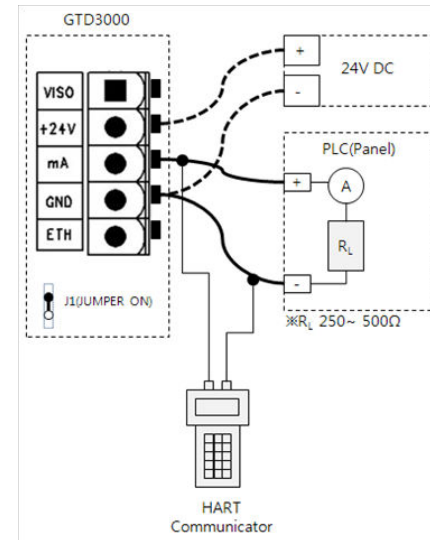

[Figure 7. 4-20mA Source Configuration]

5.3.2. Wiring for 4~20mA Sink Operation Type

- Connect (+) and (-) terminals for 4-20 mA sink output at PLC side to VISO terminal and 'mA' terminal, respectively. Then, turn off the J1 jumper.
- HART Communicator can only be used in models using HART Option board.

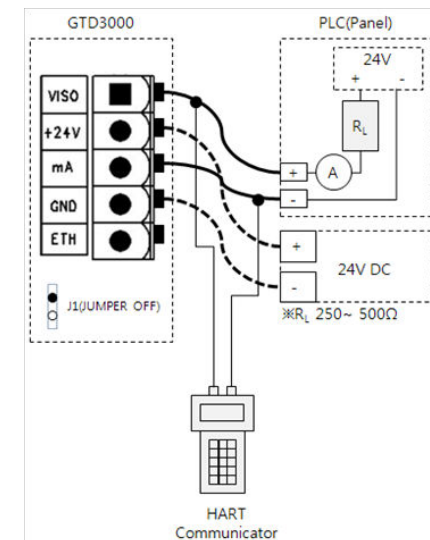

[Figure 8. 4-20mA Sink Configuration]

5.3.3. Wiring for 4~20mA 3Wire Sink Operation Type

- Connect (+) and (-) terminals for 4-20 mA sink output at PLC side to VISO terminal and power (24V DC) (-) terminal, respectively. Connect 'mA' terminal of GTD-3000Tx to 'GND' terminal. Then, turn off the J1 jumper.

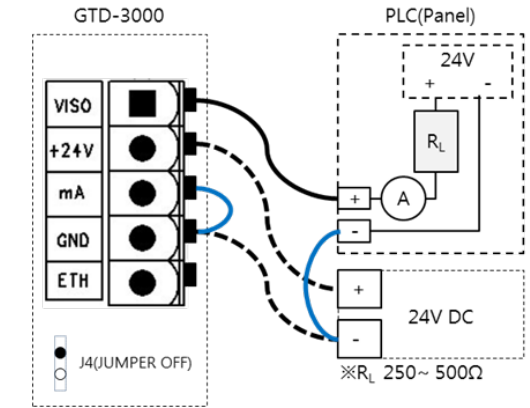

[Figure 9. 4-20mA 3Wire Sink Configuration]

5.4. Relay and Network Terminal Configuration

5.4.1. Terminal Configuration

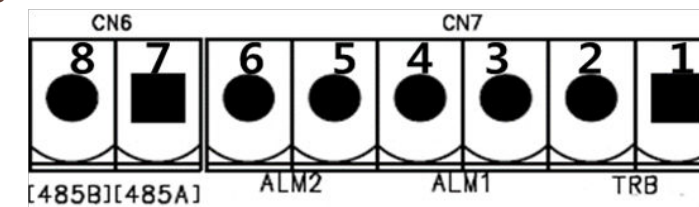

[Figure 10. Relay and RS485 Terminal]

TER. NO.	PIN NO.	Terminal Name	Description
CN7	1	TRB OUT	Trouble RELAY OUTPUT Terminal. Output mode is decided by J2 Jumper setting.
	2	TRB COM	TROUBLE RELAY COMMON Terminal
	3	AL1 OUT	ALARM1 RELAY OUTPUT Terminal. Output mode is decided by J3 Jumper setting.
	4	AL1 COM	ALARM1 RELAY COMMON Terminal
	5	AL2 OUT	ALARM2 RELAY OUTPUT Terminal. Output mode is decided by J4 Jumper setting.
	6	AL2 COM	ALARM2 RELAY COMMON Terminal
CN6	7	RS485 A	RS485 A Terminal
	8	RS485 B	RS485 B Terminal

[Table 4. Relay & RS485 Terminal Description]

5.4.2. Relay Mode Configuration

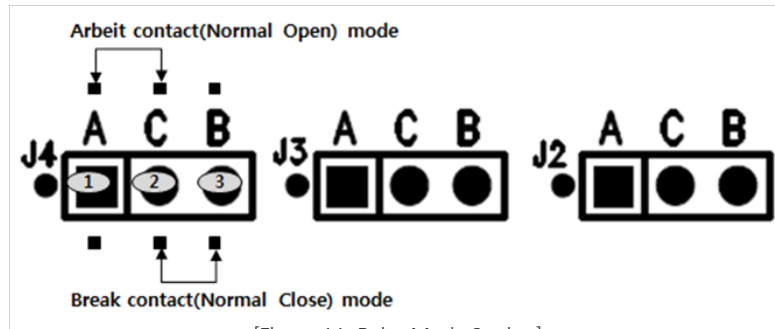

[Figure 11. Relay Mode Setting]

- Relay of GTD-3000Tx operates in 2 types of method; Normal open and Normal close. The Jumper is constructed to configure relay operation method at the Main PCB and operating setting is as follows.

TER. NO.	PIN NO.	Terminal Name	MODE Setting
CN7	1	TRB OUT	J2 A-C Connection: A Contact (Normal Open) J2 B-C Connection: B Contact (Normal Close)
	2	TRB COM	
	3	AL1 OUT	J3 A-C Connection: A Contact (Normal Open) J3 B-C Connection: B Contact (Normal Close)
	4	AL1 COM	
	5	AL2 OUT	J4 A-C Connection: A Contact (Normal Open) J4 B-C Connection: B Contact (Normal Close)
	6	AL2 COM	

[Table 5. Relay Mode Setting]

5.4.3. RS485 MODBUS Setting

- MODBUS of GTD-3000Tx is optional and is connects to the receiver as shown below.

TER. NO.	PIN NO.	Terminal Name	Receiver Terminal Name	Notes
CN6	7	485A	'TRXD+' or 'A' or 'P'	
	8	485B	'TRXD-' or 'B' or 'N'	

[Table 6. RS485 Terminal Description]

5.5. Installation Cable Length

- The maximum length between GTD- 3000Tx and power supply is decided by wire specification.
- Max. Installation Length = $V_{MAXDROP} \div I_{MAX} \div WIRER/m \div 2$
 - $V_{MAXDROP}$: Maximum Power Loop Voltage Drop (=Power Supply voltage - min operating voltage)
 - I_{MAX} : Max. Current of GTD-3000Tx
 - $WIRER/m$: The resistance of the wire (ohms/meter value available in wire manufacturer's specification data sheet)
- Example of installation lengths using 24 V power supply and 16 AWG is as follows.
 - GTD-3000Tx minimum operating voltage = 18 Vdc
 - $V_{MAXDROP} = 24 - 18 = 6V$
 - $I_{MAX} = 0.15A (150mA)$
 - $6 \div 0.15 \div 0.01318 \div 2 = 1517.451m \approx 1,517m$

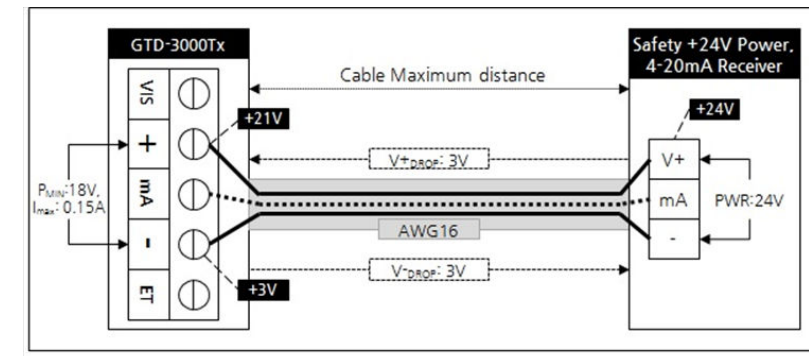

[Figure 12. Calculation of GTD-3000Tx Installation Cable Length]

- Power cable installation for each cable type is as shown in the table below.

AWG	mm ²	COPPER RESISTANCE(ohms/m)	METERS
12	3.31	0.00521	3838
14	2.08	0.00828	2415
16	1.31	0.01318	1517
18	0.82	0.02095	954
20	0.518	0.0333	600

[Table 7. GTD- 3000Tx Power Cable Installation Length]

6.1. Initial Operation Status (Power On)

- After wiring to power terminal at the top of Main PCB board then supply power, the following contents are displayed on LCD. Approx. 30 min of stabilization of time is needed from the initial supply of operation power and it starts to operate normally after sufficient stabilization.

GTD-3000 [Ver X.XX]	- When the power turns on, model name is displayed on the first row and firmware version of the detector is displayed on the second row of LCD.
** SELFTEST ** [>>>>>> 0179]	- Self test is performed for 3 min (30 min for O2 set-up), '>' symbol in the second row shows the progress.

6.2. Measuring Mode

- After power on, when there is no error from "SELF TEST", it automatically enters Measuring Mode.

[COMB.] [0]%LEL	- It runs as below when it is normal and in gas measuring mode.
* [COMB.] < 0]%LEL	- Gas name is displayed on the first row and the current measurement and unit is displayed on the second row. ※ During HART network, '*' is displayed on the left of the first row. ※ ENG. When the mode is on, '<' is displayed on the left of the second row. ※ During 485 network, '*' is displayed on the right of the first row.
[COMB.]*A01 [0]%LEL	
[COMB.] [OVER]%LEL	- When gas measurement larger than 10% of set high scale value, "OVER" displays in 1 sec interval. - At this time, 4~20 mA runs as 22 mA.
[COMB.] [UNDER]%LEL	- When gas measurement smaller than -10%, "UNDER" displays in 1 sec interval and 4~20 mA runs at 0 mA. ※ The following function only runs when UNDER is on.
[FAULT- 08] SENSOR HUNTING	- When trouble occurs in the device, it displays fault number and message. - At this time, 4~20 mA runs at 0 mA. (2 mA when HART is used.) - Fault #-8 on the left is a mode that is displayed when there is repeated hunting error from the sensor.

6.3. Operation Flow

- After power on, it passes self-diagnostic process then enters Measuring Mode. Here, by operating front keys, you can go to internal System Mode.
- Timeout for Level1 and Level2 are 10 sec. It is set to 1 h for Level2 Calibration and Test Mode.
- When "RESET: key contacts at Program Mode Screen, it returns to Measuring Mode. When "RESET" key contacts at each Program Setting Screen, it returns to the parent step.

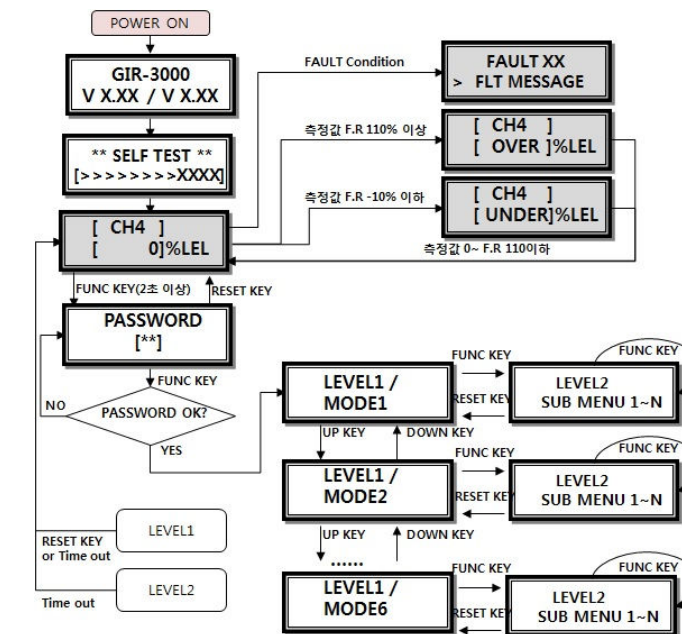

[Figure 13. GTD-3000Tx Mode Configuration]

ITEM	NAME	DESCRIPTION
FUNC	Function key	Detector Mode Setting Entry Function (Insert Magnetic-bar for 2 sec or longer in measuring mode) Level2 Next stage entering function and setting saving function
RESET	Reset key	Move to the previous stage from the level entered.
↑	Up key	Next level mode that is configured in LEVEL1 and Change in Level2 setting Plus
↓	Down key	Next level mode that is configured in LEVEL1 and Change in Level2 setting Minus

[Table 8. Operation Key Description]

6.4. Menu Configuration Table

LEVEL1	LEVEL2		DEFAULT
	NAME	PARAMETER	
PROGRAMMABLE MODE	GAS TYPE	[DEFINE/USERG.]	DEFINE
	GAS SELECT	Factory Set	COMB.
	UNIT SELECT	%/%LEL/PPM/PPB	%LEL
	DECIMAL POINT	0.100/1.00/10.0/100	100
	HIGH SCALE	1~9999	100
	PASSWORD	00~99	00
CALIBRATION MODE	CALIBRATION [ZERO]	ZERO CALIBRATION [NO, YES]	[NO]
		ZERO GAS [0]	
		ZERO PROCESSING [SUCCESS / FAIL]	
		CALIBRATION DATA [0 / FAIL]	
	CALIBRATION [SPAN]	SPAN CALIBRATION [NO, YES]	[NO]
		SPAN GAS VALUE [0]	
		SPAN SET VALUE [50 / FAIL]	50
		SPAN PROCESSING [SUCCESS / FAIL]	
	CALIBRATION DATA [0]		
ALARM PROGRAM MODE	ALARM OPERATING	[AUTO/MANUAL]	AUTO
	ALARM RELAY TYPE	DE-ENERGIZED/ENERGIZED	DE-ENERGIZED
	FAULT RELAY TYPE	DE-ENERGIZED/ENERGIZED	DE-ENERGIZED
	ALARM1 TYPE SEL. (ALARM1 TYPE SELECT)	[INCREASE/ DECREASE]	INCREASE
	ALARM1 LEVEL ADJ (ALARM1 LEVEL ADJUST)	[1~Full Scale]	20
	ALARM1 DEAD BAND	[0.0~ 10% of Full Scale]	0.0
	ALARM1 TIME SET	[0~60] SEC	1
	ALARM1 RELAY CTL (ALARM1 RELAY CONTROL)	[ON / OFF]	ON

LEVEL1	LEVEL2		DEFAULT
	NAME	PARAMETER	
ALARM PROGRAM MODE	ALARM2 TYPE SEL. (ALARM2 TYPE SELECT)	[INCREASE/ DECREASE]	INCREASE
	ALARM2 LEVEL ADJ (ALARM2 LEVEL ADJUST)	[1~Full Scale]	40
	ALARM2 DEAD BAND	[0.0~ 10% of Full Scale]% FS	0.0
	ALARM2 TIME SET	[0~60] SEC	1
	ALARM2 RELAY CTL (ALARM2 RELAY CONTROL)	[ON / OFF]	ON
	SENSOR MODE	FACTORY Mode	
MAINTENANCE MODE	FACTORY Mode		
485 MODBUS MODE	FACTORY Mode		
DEVICE MODE	FACTORY Mode		
VERSION MODE	FACTORY Mode		
TEST MODE	FACTORY Mode		
SYSTEM MODE	FACTORY Mode		

[Table 9. Menu Configuration Table]

7.1. PROGRAM MODE

PASSWORD [**]	- Contacting "FUNC" key with the Magnet-bar for 2 sec or longer in Measuring Mode enters Password mode. - After setting Password using "↑" or "↓" key, contact "FUNC" key.
PROGRAMMABLE MODE	- If password is correct, it enters Program mode. - By contacting "↑" or "↓" key, mode changes in defined order. (PROGRAMMABLE->CALIBRATION->ALARM->SENSOR->MAINTENANCE->485 MODBUS->DEVICE->VERSION->TEST->SYSTEM)
GAS TYPE [DEFINE]	- Mode that sets gas name type and contacting "↑" or "↓" key changes gas type. (DEFIN. / USERG.) - DEFINE is selected when a built-in gas name is used. USERG. Is selected to define the gas name directly by a user. - When a desired gas type is displayed, contact "FUNC" key to set the gas name and enter Program Mode.
GAS SELECT [COMB.]	- Mode that sets gas name and contacting "↑" or "↓" key changes gas name. - When gas type is set to DEFIN., built-in gas names can be selected for use. When it is set to USER, the user shall set gas name using 6 character for use. Characters allowed for use are number, capital Alphabet, space, and period. When position is moved by setting characters, a cursor in black box shape appears as shown in the figure on left.
USER GAS [■]	
UNIT SELECT [%LEL]	- Mode that sets gas measuring unit and contacting "↑" or "↓" key changes gas measuring unit. (% / %LEL / PPM / PPB). - When a desired gas measuring unit is displayed, contact "FUNC" key to set the unit and enter Program Mode.
DECIMAL POINT [100]	- Mode that changes decimal place and contacting "↑" or "↓" key changes decimal place. (0.100/1.00/10.0/100) - When a desired decimal place is displayed, contact "FUNC" key to set the decimal place and enter the next Program Mode.
HIGH SCALE [100]	- Mode that sets high scale value that should be displayed for full range. Contacting "↑" or "↓" key increases or decreases the scale value. (1 ~ 9999) - When a desired high scale is displayed, contact "FUNC" key to set the high scale value and enter the next Program Mode.
PASSWORD [00]	- It is password setting mode. This password is checked when entering Program Mode. - Default is set to "00". - Set using "↑" or "↓" key then contact "FUNC" key to set the password and enter the next Program Mode.

7.2. CALIBRATION MODE

- Due to characteristics of the gas detector, minimum 30 min of stabilization time is required and maintenance condition may change depending on site condition.

7.2.1. Zero Calibration

PASSWORD [**]	- Contacting "FUNC" key with the Magnet-bar for 2 sec or longer in Measuring Mode enters Password mode. - After setting Password using "↑" or "↓" key, contact "FUNC" key.
CALIBRATION MODE	- Contact "↑" or "↓" key to select "Calibration Mode". - Contact "FUNC" key when "CALIBRATION MODE" is displayed to enter Calibration Mode. - Contact "RESET" key to return to Measuring Mode.
CALIBRATION [ZERO]	- When "CALIBRATION MODE" is displayed, contacting "FUNC" key selects Zero Calibration. - Contact "↑" or "↓" key to achieve [ZERO] then contact "FUNC" key to enter Zero Calibration.
ZERO CALIBRATION [YES]	- Contact "↑" or "↓" key to achieve [YES] then contact "FUNC" key to perform Zero Calibration.
ZERO GAS [0]	- Using a calibration tool, inject clean air or 100% nitrogen into the sensor at a flow rate of 500 mL/min for 1 min. Contact "FUNC" key when measurement is stabilized to automatically perform Zero Calibration.
ZERO PROCESSING SUCCESS >>>>	- When zero calibration is successful, "ZERO SUCCESS" is displayed for 2 sec on LCD display then it changes to "CALIBRATION DATA" Mode. - When zero calibration is not successful, "ZERO FAIL" is displayed for 2 sec and it changes to "CALIBRATION DATA" Mode.
ZERO PROCESSING FAIL >>>>	- ZERO FAIL occurs when sensor input value exceeds 70% of total ADC input range.
CALIBRATION DATA [0]	- It is a mode to display measurement after calibration and checks whether calibration is successful after performing auto calibration. - When it failed, it displays "FAIL" and the current measurement in 1 sec interval. - Contact "RESET" key to return to "Calibration mode".

7.2.2. Span Calibration

CALIBRATION MODE	<ul style="list-style-type: none"> - Contact "↑" or "↓" key to select "Calibration Mode". - Contact "FUNC" key when "CALIBRATION MODE" is displayed to enter Calibration Mode. - Contact "RESET" key to return to Measuring Mode.
CALIBRATION [SPAN]	<ul style="list-style-type: none"> - Contact "↑" or "↓" key to achieve [SPAN] then contact "FUNC" key to enter Span Calibration mode.
SPAN CALIBRATION [YES]	<ul style="list-style-type: none"> - Contact "↑" or "↓" key to achieve [YES] then contact "FUNC" key to perform Span Calibration.
SPAN GAS VALUE [0]	<ul style="list-style-type: none"> - Using a calibration tool, inject the standard gas to the sensor at a flow rate of 500 mL/min for 90 sec. After the measurement is stabilized, contact "FUNC" key to enter the next mode. - When Hold function in Maintenance Mode is on, the current maximum SPAN gas value is held and displayed in the first row. - The current measurement is displayed in the second row.
[0] < 0]	
SPAN SET VALUE [50]	<ul style="list-style-type: none"> - It is a mode to set standard gas value. When there is no "Fail" message, contact "↑" or "↓" key to set a value. - When the inject standard gas value is abnormal, it displays Fail message. Fail message is as follows. Fail message and span set value are displayed alternatively.
CALIBRATION DATA	<ul style="list-style-type: none"> ① "LOW FAIL" occurs when the difference between injected gas value and zero calibration value is below 1%. ② "HIGH FAIL" occurs when injected gas value is above 95% of total ADC input range.
CALIBRATION DATA CAL HIGH ERROR	<ul style="list-style-type: none"> - "RING FAIL" occurs when injected gas value runs in the current set span value, it exceeds 95% of ADC input range. The above FAIL messages are automatically released if the status is normal after adjusting SPAN value.
SPAN PROCESSING SUCCESS >>>>	<ul style="list-style-type: none"> - After completing the standard gas value setting, contacting "FUNC" key automatically runs Span Calibration. When it succeeds, "SPAN PROCESSING SUCCESS" is displayed on LCD display for 2 sec then it changes to "CALIBRATION DATA" Mode.
SPAN PROCESSING FAIL >>>>	<ul style="list-style-type: none"> - When span calibration is not successful, "SPAN PROCESSING FAIL" is displayed for 2 sec and it changes to "Calibration Data Mode".
CALIBRATION DATA [0]	<ul style="list-style-type: none"> - It is a mode to display measurement after calibration and checks whether calibration is successful after performing auto calibration. - Contact "RESET" key to return to "Calibration mode".

7.3. ALARM MODE

PASSWORD [**]	<ul style="list-style-type: none"> - Contacting "FUNC" key with the Magnet-bar for 2 sec or longer in Measuring Mode enters Password mode. - After setting Password using "↑" or "↓" key, contact "FUNC" key.
ALARM PROGRAM MODE	<ul style="list-style-type: none"> - Contact "↑" or "↓" key to select "Alarm Program Mode". - Contact "FUNC" key when "ALARM PROGRAM MODE" is displayed to enter Alarm setting mode. - Contact "RESET" key to return to Measuring Mode.
ALARM OPERATING [AUTO]	<ul style="list-style-type: none"> - It is a mode that sets reset method after an event of alarm. Contacting "↑" or "↓" key changes between "AUTO" and "MANUAL".
ALARM OPERATING [MANUAL]	<ul style="list-style-type: none"> - "AUTO" mode automatically resets the alarm. "MANUAL" mode resets the alarm only when Reset key is pressed.
ALARM RELAY TYPE DE-ENERGIZED	<ul style="list-style-type: none"> - It is a mode that sets Reset method after an event of Alarm. Contacting "↑" or "↓" key changes between "DE-ENERGIZED" and "ENERGIZED". - "DE-ENERGIZED" deactivates energizer mode and "ENERGIZED" activates energizer mode.
FAULT RELAY TYPE DE-ENERGIZED	<ul style="list-style-type: none"> - It is a mode that sets Reset method after an event of FAULT. Contacting "↑" or "↓" key changes between "DE-ENERGIZED" and "ENERGIZED". - "DE-ENERGIZED" deactivates energizer mode and "ENERGIZED" activates energizer mode.
ALARM1 TYPE SEL. [INCREASE]	<ul style="list-style-type: none"> - It is a mode that sets operational direction of Alarm1. Contact "↑" or "↓" key to display "INCREASE" or "DECREASE".
ALARM1 TYPE SEL. [DECREASE]	<ul style="list-style-type: none"> - "INCREASE" mode runs when the value is at Alarm1 threshold or higher. "DECREASE" mode runs when the value is at Alarm 1 threshold or lower.
ALARM1 LEVEL ADJ [20]	<ul style="list-style-type: none"> - It is a mode that sets Alarm1 level threshold. Contact "↑" or "↓" key to increase or decrease Alarm1 level, respectively. - When a desired alarm 1 threshold is displayed, contact "FUNC" key to set it and enter the next item.
ALARM1 DEAD BAND [0.0]%FS	<ul style="list-style-type: none"> - It is a mode that sets operation range of Alarm1. Contact "↑" or "↓" key to increase or decrease the value, respectively. - When Alarm1 is in "INCREASE" mode, it runs at Alarm1 threshold + Dead band and is released at Alarm1 threshold - Dead band. - When a desired value is displayed, contact "FUNC" key to set the dead band value and enter the next Alarm Program Mode
ALARM1 TIME SET [1] SEC	<ul style="list-style-type: none"> - It is a mode that sets Alarm1 dwell time. Contact "↑" or "↓" key to increase or decrease the value, respectively. - Displayed number is in sec and in a range from 0 to 60. When a desired value is displayed, contact "FUNC" key to set the alarm dwell time and enter the next Alarm Program mode.

ALARM1 RELAY CTL [ON]	- It is a mode that sets whether to contact relay contact during Alarm1 operation. Contact "↑" or "↓" key to change the display between "ON" or "OFF". - In ON mode, relay runs during Alarm1 operation. In OFF mode, relay do not run during Alarm1 operation.
ALARM2 TYPE SEL. [INCREASE]	- It is a mode that sets operational direction of Alarm2. Contact "↑" or "↓" key to display "INCREASE" or "DECREASE".
ALARM2 TYPE SEL. [DECREASE]	- "INCREASE" mode operates when the value is equal or larger than set alarm threshold. "DECREASE" mode operates when the value is equal or less than set alarm threshold.
ALARM2 LEVEL ADJ [40]	- It is a mode that sets Alarm2 level. Contact "↑" or "↓" key to increase or decrease Alarm2 level, respectively. - When a desired alarm 2 threshold is displayed, press "FUNC" KEY to set it and enter the next Alarm Program mode.
ALARM2 DEAD BAND [0.0]%FS	- It is a mode that sets operational direction of Alarm2. Contact "↑" or "↓" key to increase or decrease the value, respectively. - When Alarm2 is in "INCREASE" mode, it runs at Alarm1 threshold + Dead band and is released at Alarm2 threshold - Dead band. - When a desired value is displayed, contact "FUNC" key to set the dead band value and enter the next Alarm Program Mode
ALARM2 TIME SET [1] SEC	- It is a mode that sets Alarm2 dwell time. Contact "↑" or "↓" key to increase or decrease the value, respectively. - Displayed number is in sec and in a range from 0 to 60. When a desired value is displayed, contact "FUNC" key to set the alarm dwell time and enter the next Alarm Program mode.
ALARM2 RELAY CTL [ON]	- It is a mode that sets whether to contact relay contact during Alarm2 operation. Contact "↑" or "↓" key to change the display between "ON" or "OFF". - In ON mode, relay runs during Alarm2 operation. In OFF mode, relay do not run during Alarm2 operation.

8.1. Fault List

FAULT MESSAGE	DESCRIPTION & CONDITION	CAUSE
FAULT2 "SEN HIGH"	Sensor output is above ADC max. value.	Defective sensor module or transmitter board ADC
FAULT3 "SEN LOW"	Sensor output is below ADC min. value.	Defective sensor module or transmitter board ADC
FAULT4 "EROM ERR"	Defective Transmitter EEPROM Checksum	Defective Transmitter Board EEPROM
FAULT5 "+24V LOW"	It occurs when 24 V main input power is inputted with voltage below 17V.	Input power below 17 V or defective Transmitter ADC
FAULT6 "ADC FAIL"	Defective Transmitter ADC	Defective Transmitter ADC
FAULT7 "H/W REV"	H/W Version Error	Defective MPU inside Transmitter
FAULT8 "SEN HUNT"	When there is repeated hunting error in gas measurement	Sensor output status may be poor or check for input power noise.

[Table 10. Fault List]

8.2. Recovery List

No	CAUSE	SOLUTION
1	Defective Sensor Module	Change Sensor
2	Defective Transmitter Board ADC	Change Transmitter Board
3	Defective Transmitter Board EEPROM	1) Perform Factory Initialization then correct parameter and re-calibrate 2) Change sensor unit when the same problem occurs again
4	Defective MPU inside Transmitter	Change Transmitter Main Board
5	Poor Sensor Output Status	Change Sensor
6	Check Input Power Noise	Check External Input Voltage Noise Status

[Table 11. Recovery List]

9.1. MODBUS RS485

9.1.1. Interface setting

- Data Format: RTU
- Baud rate: 9600 bps
- Data bits: 8bits
- Stop bit: 1bits
- Parity: Even
- For details, please go to www.modbus.org

9.1.2. MODBUS RS485 Address map

TYPE	ADDRESS	BITS	DESCRIPTION
Measured Gas Concentration	30001	BIT15~0	Gas Measurement (Integer/Decimal point is not considered)
High Scale Setting	30002	BIT15~0	High Scale Setting (Integer/Decimal point is not considered)
Alarm 1 Setting	30003	BIT15~0	Alarm 1 Setting (Integer/Decimal point is not considered)
Alarm 2 Setting	30004	BIT15~0	Alarm 2 Setting (Integer/Decimal point is not considered)
Gas detector status value	10000	BIT0	Alarm 1 Active Status
		BIT1	Alarm 2 Active Status
		BIT2	Fault Active Status
		BIT3	Maintenance Mode Status
		BIT4	Test Mode Status
		BIT5	Calibration Mode Status
		BIT6	Reserved
		BIT7	Toggle Bit (Bit reversal in 2 sec interval)
External Test	3	BIT0~7	Gas Detector Test Mode Setting
External Reset	2	BIT0~7	Exit Gas Detector Test Mode

[Table 12. RS485 MODBUS Address Configuration]

10.1. Standard Type

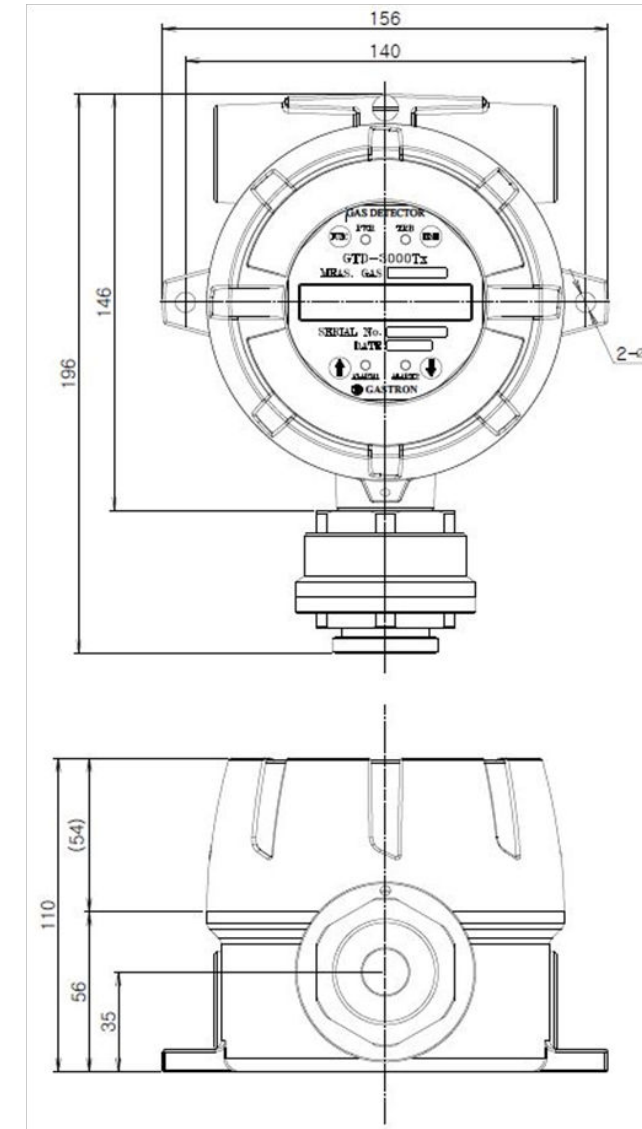

[Figure 14. GTD-3000Tx Standard Type Drawing]

10.2. When Connecting Warning Light

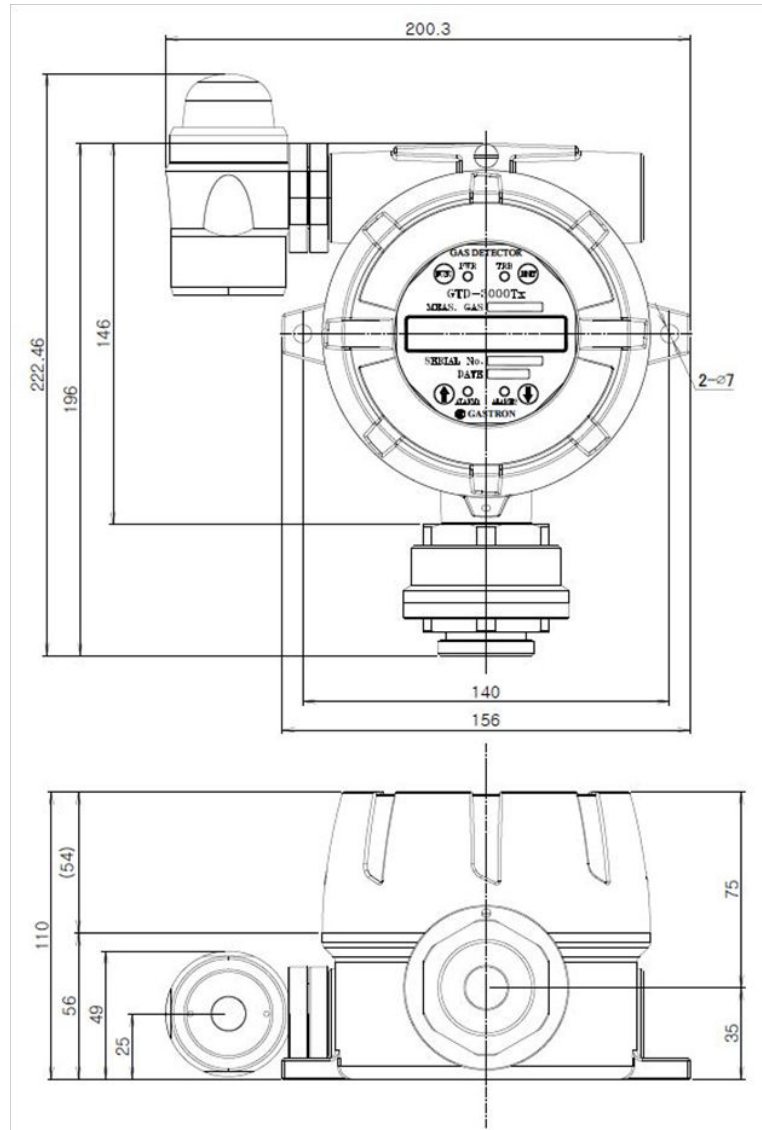

[Figure 15. GTD-3000Tx Warning Light Connection Drawing]

10.3. For Rain cover Assembly

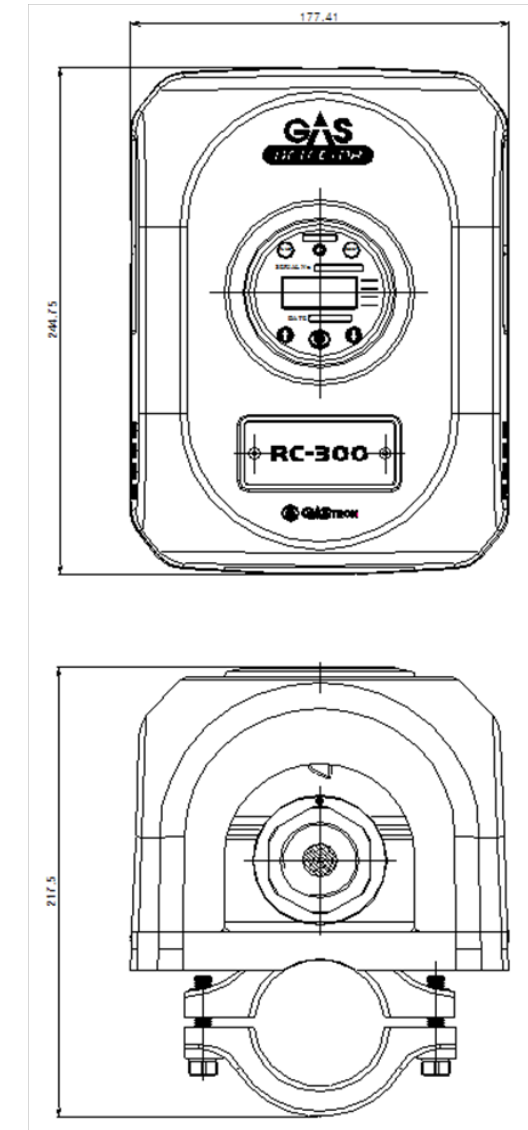

[Figure 16. GTD-3000Tx Rain Cover Assembly Drawing]

11.1. Selecting a Place for Installation (Occupational Health & Safety Act Data)

A gas leak detector alarm shall be installed in the following places.

- Around chemical equipment and accessories that have concerns of gas leak. This includes compressors, valves, reactors, pipe joints, etc. installed inside and outside of a building that handle combustible and toxic materials.
- Places that are easier for gases to stay such as areas around manufacturing facilities with ignition sources like heating furnace, etc,
- Areas around equipment for filling combustible and toxic materials.
- Substations, panel rooms, control rooms, and etc. located within explosive area.
Other areas that are easier for gases to stay.

11.2. Selecting a Site for Installation (High-Pressure Gas Safety Control Act Data)

Gas detector of gas leak detector alarm must be installed as close to the areas with concerns of gas leakage as possible. However, for areas where direct gas leakage is not expected but are easier for leaked gas to stay, the detector must be installed at the point 1 of the following.

- Gas leak detector alarm installed outside a building shall be installed at points where gas is likely to stay in consideration to wind direction, wind speed, specific gravity of gas, etc.
- Gas leak detector alarm installed inside a building shall be installed near the floor when the specific gravity of gas is heavier than air and near ventilation of ceiling when it is lighter than air.
- Alarm for gas leak detector alarm must be installed at sites where the gas detector is installed and workers are present.

11.3. Precautions during Installation

Avoid areas with electrical barriers such as rain water, etc. It is recommended to be installed in areas that are easier to work in since regular maintenance is needed. Avoid areas with vibration or shock since they can affect output values. Sensor part must be installed towards the direction of gravity.

- This equipment has explosion-proof construction for internal pressure and belongs to GROUP II for gas and vapor in general work sites and chemical plants. It can be used in ZONE 1 (ONE) and ZONE 2 (TWO) hazardous sites.
- Allowable temperature is 85 C or below, which corresponds to T6.
- Surrounding temperature shall be in a range of -20 to 60°C (For the main unit and sensor, refer to each sensor manual.)

- Relative Humidity: 5% ~ 99% (Non-condensing)
- Installation Site: Indoor and Outdoor
- Explosion Ignition Group for Target Gas or Vapor: Ex d IIC T6
- During wiring work, use explosion-proof cable gland at cable inlet or tightly seal cable conduit during metal cable wiring construction to prevent spread of flames in case of explosion or movement of gas, etc. through the cable conduit within 50 mm. All materials including materials used for sealing of unused inlets must have safety certificates!
- When connecting the equipment with cable, screw thread must be tightened 5 threads or more.
- Work in conditions satisfying other [Standards for Selection, Installation, and Maintenance, etc. of Explosion-proof Electric Machine and Equipment Wiring, etc. at Work Site]

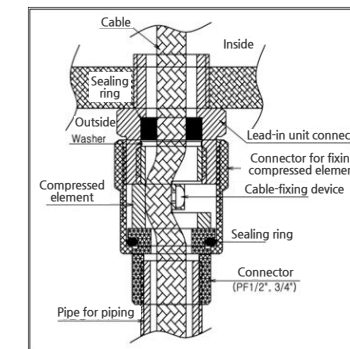

[Figure 17. High-Pressure Packing Type]

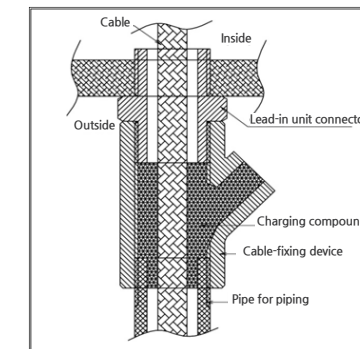

[Figure 18. Y Sealing Compound]

VERSION	CONTENTS	DATE
0.0	* Initial Revision of the manual	2013. 07. 11
1.0	* Added function in Maintenance Mode * Modify Version Display	2014. 07. 01
1.1	* Changed to Naver Font	2016. 03. 19
1.2	1> Added SPAN SKIP MENU 2> Added Menu for INSERT TYPE SENSOR 3> Added FAULTS	2016. 08. 16
2.0	* Separated Factory mode manual	2016. 12. 06
3.0	* Changed Explosion-proof Equipment Cable Entry Installation Regulation 45 cm → 50 mm	2017. 01. 20
3.1	1> Corrected 4-20 Analog Output Display Error 2> Changed output during Maintenance Mode	2017. 05. 04
3.2	* Corrected changed detailed operation. Added Warning message	2017. 11. 28
3.3	* Correct typos and typographical errors	2019. 11. 19