

## GTD-5000 Sampling Flammable Gas Detector

- | Fast response of flammable gases leakage with a high efficient pump inside
- | Self diagnosis function with built-in Microprocessor
- | Easy replacement with a cartridge type sensor
- | Digital flow sensor to maintain regular flow rate
- | Detection gas from low to high concentration owing to various detection principle
- | Stable quality and proved detection principle for service life
- | Fine LCD display for showing various information
- | 4-digit digital gas concentration display
- | 4-20mA (Current source or Sink) output signal
- | Easy configuration of monitoring by RS-485 Modbus or PoE
- | 2-stage alarm, 1-trouble display and relay contact output
- | 3-wire connection for signal & power
- | Calibration and maintenance by one-man

### IMAGE



### DIMENSION (Unit : mm)

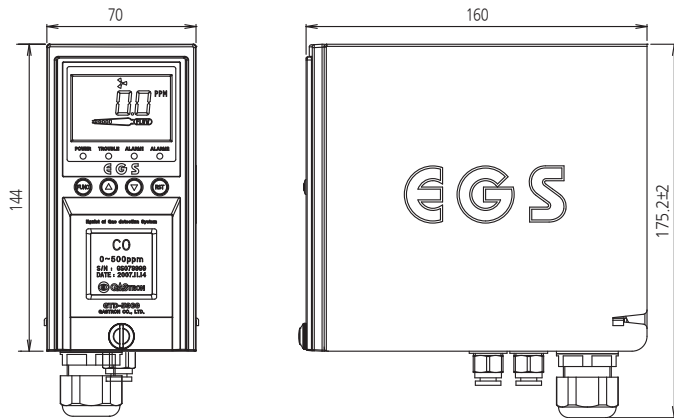

### ACCESSORIES

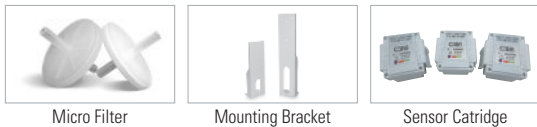

Micro Filter

Mounting Bracket

Sensor Cartridge

### SPECIFICATION

※ Specifications are subject to be changed without prior notice.

INTELLIGENT & SAMPLING TYPE FLAMMABLE GAS DETECTOR				
Model	GTD-5000			
Measuring gas	Flammable gases (LNG, LPG, H <sub>2</sub> , Methane, Buthane & etc)			
Measuring type	Auto Sampling type			
Measuring method	Catalytic cell	Hot wire semiconductor cell	Thermal conductivity cell	Electro Chemical (H <sub>2</sub> )
Measuring range	0-100% LEL	0-2000ppm	0-100% Vol	0-9999ppm (H <sub>2</sub> )
Response time	<15 sec / 90% scale			
Accuracy	±3% / Full scale			
Parameter control	Front switch (calibration, maintenance, alarm setting)			
Operation mode display	4-LED (Power, 2-stage alarm, 1-trouble)			
Measuring value display	LCD Display(4-Digit)			
Alarm signal output	2A@30VDC, 0.5A@125VAC (resistive load) / 3-SPST relay contact(2stage alarm, 1 trouble)			
Output signal	4 - 20mA DC	RS-485 Modbus(Optional)	PoE(Power over Ethernet)(Option)	
Sampling method	Diaphragm Pump			
Sampling line	OD 1/4" (Standard)			
Flow rate	0 - 1000 ml/min max			
Conduit connection	Cable gland(PG-16)			
Mounting type	Wall mount			
Operating temperature	-10°C ~ +60°C			
Operating humidity	5 to 99% RH (Non-condensing)			
Material	Front(Poly carbonate), Sides(Steel)			
Dimensions	Standard type : 70(W) × 144(H) × 160(D) mm			
Weight	Standard type : 2.5kg			
CERTIFICATION				
CE / CPA	Refer to website			