

GTD-5100F Explosion Proof Type interference gas filtering gas detector

| Built-in explosion-proof structure, installed in dangerous area of gas leakage, continuously detecting gas | Application of anti-malfunction algorithm to interference gas (Ethanol, FC-3283, IPA) | Fast response speed by applying new infrared measurement principle | Built-in high-performance pump to detect gas leakage quickly | Built-in automatic flow control with flow sensor | Built-in self-diagnosis function | Application of proven detection principle with stable quality and service life | Parameter setting of color graphic LCD and 1: 1 conversation method using magnet bar | 4-20mA (Current source or Sink) output | Easy to install monitoring system by RS-485 Modbus and PoE communication | Two-stage alarm, one fault indication and relay contact output | Built-in Data & Event log function | Calibration and maintenance by one-man |

IMAGE



DIMENSION (Unit : mm)

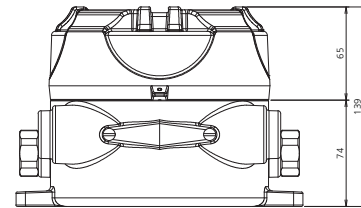
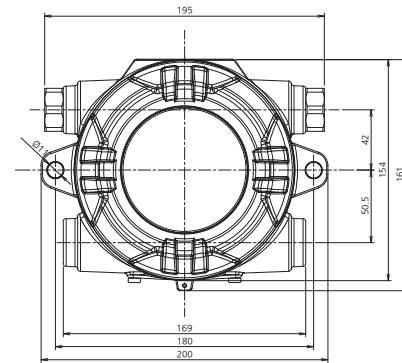

ACCESSORIES



Cable Gland



Male Connector



Micro Filter

SPECIFICATION

※ Specifications are subject to be changed without prior notice.

FLAME PROOF TYPE INTERFERENCE GAS FILTERING GAS DETECTOR			
Model	GTD-5100F		
Measuring gas	Freon gas	Flammable gas	Toxic gases (COS, TEOS)
Measuring type	Auto Sampling type		
Measuring method	Infra - red		
Measuring range	0~2000ppm	0~5000ppm, 0~100% LEL	refer to Toxic Gas Measuring Range
Response time	< 10sec / 90% scale		
Accuracy	±3% / Full Scale		
Parameter control	Non intrusive control with a Magnet bar (calibration, maintenance, alarm setting)		
Operation mode display	4-LED (Power, 2-stage alarm, 1-trouble)		
Measuring value display	Color graphic LCD display (Gas value, Gas name, Flow, Error etc.)		
Alarm signal output	5A@250VAC / 3-SPST relay contact(2stage alarm, 1 trouble)		
Output signal	Analog output : 4-20mA DC		Digital output : RS-485 Modbus / PoE (Power over Ethernet) (Option)
Sampling method	Diaphragm Pump		
Sampling line	OD 1/4 "(Standard)		
Flow rate	100 ~ 1000 ml/min (Normal 500ml/min)		
Material	ALDC		
Conduit connection	Standard : PF 3/4"	Option : NPT 1/2", NPT3/4", M20 x 1.5P, M25 x 1.5P	
Mounting type	Wall mount		
Operating temperature	-20℃ ~ +60℃		
Operating humidity	5 to 99% RH (Non-condensing)		
Dimensions	195(W) × 139(H) × 154(D) mm		
Weight	4kg		
CERTIFICATION			
KCs	Ex d IIC T6	CE	Refer to website