

# GTD-5100F Explosion Proof Type Sampling Flammable Gas Detector

| Continuous detection of Flammable gas in explosion hazardous area with flame proof structure | Self diagnosis function with built-in Microprocessor | Easy replacement with a cartridge type sensor | Digital flow sensor to maintain regular flow rate | Fast response of gas leakage with a high efficient pump inside | Low concentration VOC gas detection by PID sensor | Stable quality and proved detection principle for service life | Auto calibration and program setting with magnet bar on FND display board | 4-Digit digital gas concentration display | 4-20mA (Current source or Sink) output signal | Easy configuration of monitoring by RS-485 Modbus communication | 3-Wire Type | 2-stage alarm, 1-trouble display and relay contact output | Calibration and maintenance by one-man |

## IMAGE



## DIMENSION (Unit : mm)

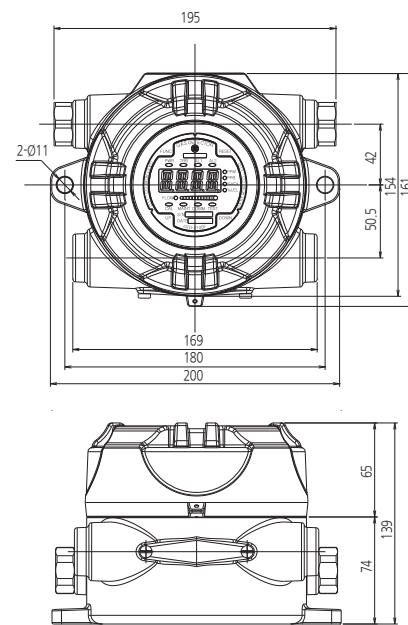

## ACCESSORIES

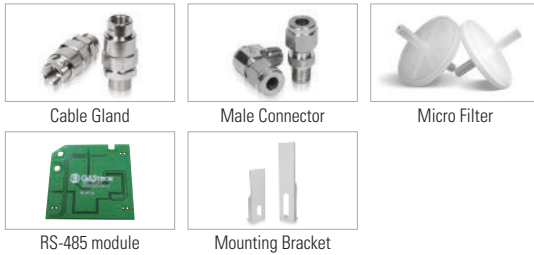

Cable Gland

Male Connector

Micro Filter

RS-485 module

Mounting Bracket

## SPECIFICATION

※ Specifications are subject to be changed without prior notice.

EXPLOSION PROOF & SAMPLING TYPE FLAMMABLE GAS DETECTOR			
Model	GTD-5100F		
Measuring gas	Flammable gases (LNG, LPG, H <sub>2</sub> , Methane, Buthane & etc)		
Measuring type	Auto Sampling type		
Measuring method	Catalytic cell	Hot wire semiconductor cell	Thermal conductivity cell
Measuring range	0-100% LEL	0-2000ppm	0-100% Vol
Response time	< 15sec / 90% scale		
Accuracy	±3% / Full Scale		
Parameter control	Front switch (calibration, maintenance, alarm setting)		
Operation mode display	Alarm / Trouble LED , Flow rate		
Measuring value display	FND Display(4-Digit)		
Alarm signal output	2A@30VDC, 0.5A@125VAC (resistive load) / 3-SPST relay contact(2stage alarm, 1 trouble)		
Output signal	Analog output : 4-20mA DC      Digital output : RS-485 Modbus(Optional)		
Sampling method	Diaphragm Pump		
Sampling line	OD 1/4 "(Standard)		
Flow rate	0 - 1000 ml/min max		
Conduit connection	Standard : PF 3/4"	Option : NPT 1/2", NPT3/4", M20 x 1.5P, M25 x 1.5P	
Mounting type	Wall mount		
Operating temperature	-20°C ~ + 60°C		
Operating humidity	5 to 99% RH (Non-condensing)		
Material	ALDC		
Dimensions	195(W)x139(H)x154(D)mm		
Weight	4kg		
CERTIFICATION			
KCs	Ex d IIC T6	CE	Refer to website