

GASTRON

Headquarters / Engineering research laboratory :
23 Gunpo Advanced Industry 1-ro(Bugok-dong), Gunpo-si, Gyeonggi-do
Tel +82-31-490-0800 Fax +82-31-490-0801

Yeongnam business office / Plant :
55 Gonghangap-gil 85beon-gil, Gangseogu, Busan Metropolitan City
Tel +51-973-8518 Fax +51-973-8519

E-mail : info@gastron.com

www.gastron.com

GTD-1000Tx(2W)

Instruction Manual



GASTRON

GASTRON

Read in detail for correct use.

Gas & Flame Detection System

GASTRON



When abnormalities occur after purchasing the product, please contact the following address.

- Address : 23 Gunpo Advanced Industry 1-ro, Gunpo-si, Gyeonggi-do
- Tel : 031-490-0800
- Fax : 031-490-0801
- URL : www.gastron.com
- e-mail : info@gastron.com

We sincerely thank you for purchasing the product of Gastron Co. Ltd.

Our Gastron Co.Ltd. is a company specialized in Gas detector and Gas Monitoring System, being recognized by many consumers due to the best quality and use convenience. We always enable you consumers to find desired products nearby and are ceaselessly studying and striving for development of Gas detectors satisfying customers. From now on, solve all anguishes concerning Gas detector with the products of Gastron Co. Ltd, We Gastron Co. will take a responsibility and give you satisfaction.

In the present instruction manual, operation method for Gas detector as well as simple methods for maintenance and repair, etc. are recorded. If you read it in detail and keep it well, for reference when you have questions, then it will give you much help.

- For accurate operation of Gas detector, check up and calibrate for more than once in every 6 months. (* In reference to KOSHA GUIDE: P-135/6-2018 / 7.2 In-house inspection, section 2)
- For accurate operation of Gas detector, checkup and calibration with calibration gas before measurement is recommended.
- When not calibrated, it may cause malfunction of the equipment due to problems resulting from Sensor aging.
- When the present instrument should be dismantled, those with professional skills for Gas detector should conduct the operation.
- For power supply cable, wire specifications should be determined by referring to the item of "Length of installed cable".
- For the contents on checkup and calibration of Gas detector, please use our company's engineering department , e-mail, or web site.

The present product and the product manual can be changed without advance notice for performance improvement and use convenience of the product.

* KOSHA GUIDE : P-135/6-2018

Calibration must be performed at a frequency requested by the manufacturer and shall be performed quarterly when the calibration period is not specified.

1. Overview	6	9. Revision History	21
2. Configuration	6		
3. Specification	7		
3.1. Basic Specifications	7		
3.2. Mechanical Specifications	7		
3.3. Electrical Specifications (Standard Type)	8		
3.4. Environmental Specifications	8		
4. Name and Description of Each Part	9		
4.1. Components	9		
5. Installation	11		
5.1. Detachment of Housing Cover	11		
5.2. Main PCB Configuration	12		
5.3. Power Signal and Terminal Configuration	13		
5.4. Method to Connect to External Control Unit	14		
5.5. Installation Cable Length	15		
6. Calibration and Maintenance	16		
6.1. 4-20mA Output Diagnosis	16		
6.2. 4mA Adjustment (ZERO Calibration)	16		
6.3. SPAN Calibration	17		
7. Drawings and Dimensions	18		
8. Precautions before Installation	19		
8.1. Selecting a Place for Installation (Occupational Health & Safety Act Data)	19		
8.2. Selecting a Site for Installation (High-Pressure Gas Safety Control Act Data)	19		
8.3. Precautions before Installation	19		

GTD-1000Tx(2-wire, referred to as 2W herein after) toxic gas detector has been developed to detect gas leaked from industrial sites and various toxic gases generated from factories, gas storages, and manufacturing processes that produce or use toxic gases and to prevent accidents in advance.

GTD-1000Tx(2W) toxic gas detector is installed in areas with gas leak hazards and continuously monitors gas leak. It displays measurements on LCD of the detector, converts and transmits data in DC 4~20 mA standard output signal. Also, for DC 4~20 mA standard output, output signal transmission length between detector and receiver can be connected up to 2,000 m. (When Cable CVVS or CVVSB 1.5sq and above is used.)

2. Configuration

Body of GTD-1000Tx(2W) is made of Aluminum alloy and the gas sensor module is made of stainless steel. It consists of a complete explosion-proof enclosure (Ex d IIC T6). This product can be installed in areas with potential combustible gas leak and explosion hazards and internal structure consists of 1 PCB board with display part for measurements and terminal part that outputs measurements (DC 4 - 20 mA) externally. External configuration consists of detector part that monitors gas leak and cable inlets.

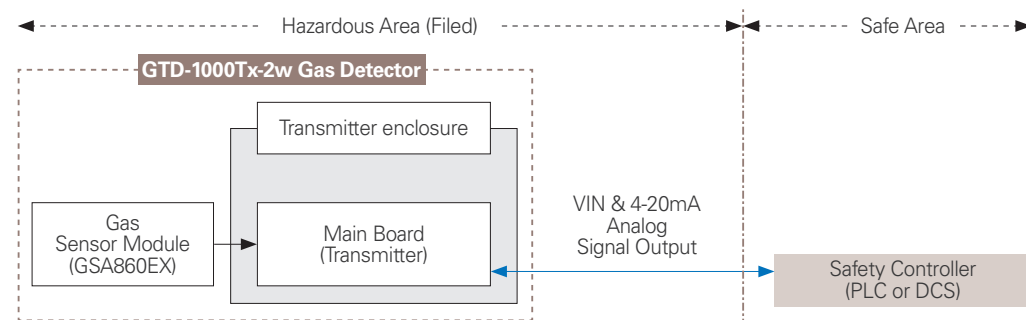

[Figure 1. GTD-1000Tx(2W) Overview]

3.1. Basic Specifications

ITEMS	SPECIFICATION	
Measuring Type	Diffusion	
Measuring Method	Electro-Chemical Cell	
Detectible Gas	Toxic Gas)(Note1	
Measuring Range	Capable to display 000.0 ~ 9999 (Note 1)	
Accuracy	≤ ±3% / Full Range	
Zero Drift	≤ 2% / Full Range	
Response Time	Depends on Sensor Module. Refer to Sensor Specification or Contact in case for Special Gas.	
Approvals Classification	KCs: Ex d IIC T6	
Basic Interface	Analog 4-20mA current interface	
Option	Rain Cover	
Warranty	Transmitter	2Year
	Sensor	1Year

※ Note1. Refer to the measured gas list for measured gases and their ranges. Contact us for special gas.

3.2. Mechanical Specifications

ITEMS	SPECIFICATION	
Explosion Proof type	Explosion-proof enclosure	
Dimension	136(W) × 166(H) × 95 (D) mm	
Weight including Sensor	App. 1.5kg	
Mounting type	Wall mount	
Mounting Holes	∅ 7 ±0.1	
Cable inlet	3/4" PF (1/2" or 3/4" NPT)	
Body material	Transmitter	aluminum alloy
	Sensor	Stainless Steel (STS316)

3.3. Electrical Specifications (Standard Type)

ITEMS	SPECIFICATION	
Input Voltage(Standard) ※ Customer supplied PSU must meet requirements IEC1010-1 and CE Marking requirements.	Absolute min: Nominal: Absolute max: Ripple maximum allowed:	16V 24V 31V 1V pk-pk
Wattage	Max. wattage: Max. current:	0.5W @+24 VDC 22mA @+24 VDC
Analog output Current	0-20mA(500 ohms max load) All readings ± 0.2mA Measured-value signal: 4mA(Zero) to 20mA(Full Scale)	
	Fault: 0-100% LEL: 100-109%LEL: Over 110% LEL: Maintenance:	3mA 4mA - 20mA 21.6mA 20mA - 21.4mA 3.5mA
Analog output current ripple & noise max	±20uA	
Wiring requirement	Power	CVVS or CVVSB with shield
Cable Connection Length	Analog	2500m
EMC Protection:	Complies with EN50270	

3.4. Environmental Specifications

ITEMS	SPECIFICATION	
Operation Temperature	Transmitter	-20 to 50 °c
	Sensor	Refer to Sensor Specification
Storage Temperature	Transmitter	-20 to 50 °c
	Sensor	Refer to Sensor Specification
Operation Humidity	Transmitter	5 to 99% RH (Non-condensing)
	Sensor	Refer to Sensor Specification
Pressure Range	90 to 110KPa	
Max. air velocity	6m/s	

4.1. Components

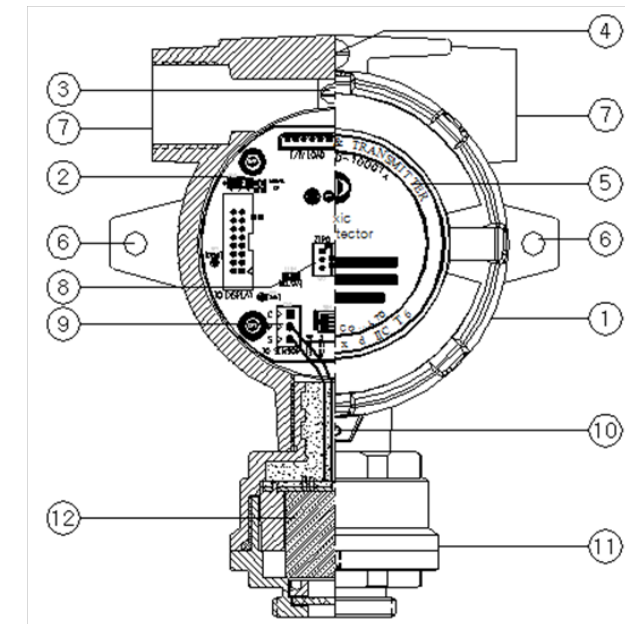

[Figure 2. GTD-1000Tx(2W) Components]

NO	NAME	DESCRIPTIONS
1	Detector housing body	Protects PCB Board built in Sensor and Housing from external environmental change and shock.
2	Main PCB	Amplifies fine outputs generated from Sensor Element and It transmits by converting into DC standard output.
3	Internal Ground	It must be grounded to inside of detector for protection from external noise or strong electric field.
4	External Ground	It must be grounded to outside of detector for protection from external noise or strong electric field.
5	Detector Housing Cover	Protects PCB Board built in Sensor and Housing from external environmental change and shock.
6	Mount Hole	Hole to fix the gas detector on external wall or other installation sites.
7	Conduit Connection	It is supplied for inlet of power supply and measurement output signal for the detector during installation. For cable inlet, PF or NPT 3/4", 1/2" are prepared
8	Zero / Span VR	It is variable resistance that adjusts zero and span during calibration

NO	NAME	DESCRIPTIONS
9	Sensor Terminal	CN5 is Sensor Connection Terminal. (Blue ,Red, White,)
10	Set screw (M4-L6)	It is a set screw that prevents cover opening from the detector housing body.
11	Sensor head	It protects the gas sensor from external shock, dusts, and rainwater, etc.
12	Sensor	It is a site that detects actual gas leak. It converts the amount of gas leak into electrical signal and transmits to the Main PCB.

[Table 1. GTD-1000Tx(2W) Components Description]

- It is prohibited for an individual, other than an approved user or a technician responsible for installation and repair from the head office, to install a gas leak sensor on site or open the cover of the installed gas leak detector and manipulate it. This may cause serious loss of life and property from fire, explosion, and etc. In addition, please check whether there is any remaining explosive gas or combustible material in the surroundings. Power must be turned off before performing work.

5.1. Detachment of Housing Cover

- Turn the slotted set screw (M4 x 1ea) fixing the cover part of main body 3~4 turns counter clockwise (ccw) using a hex wrench (M2) then turn the cover of gas leak detector ccw to detach the cover.

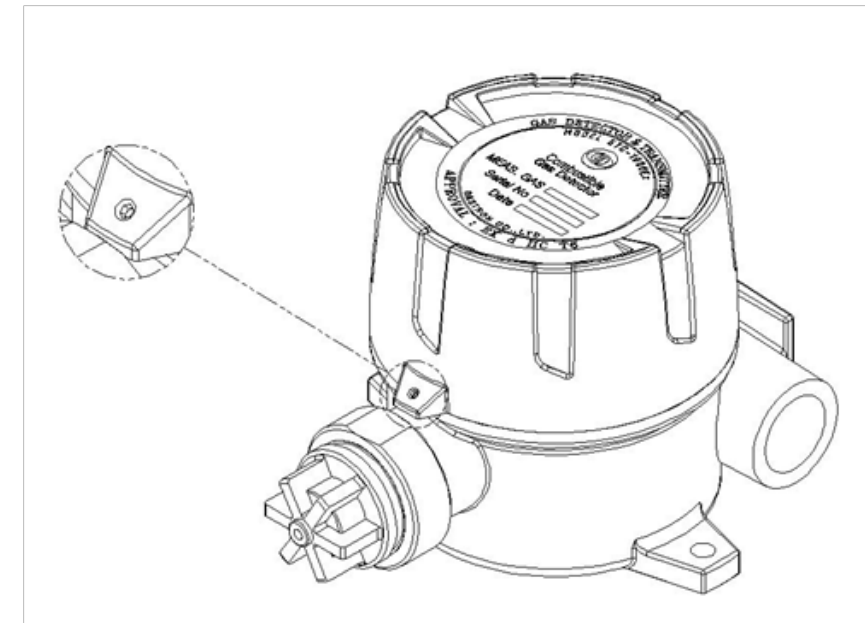

[Figure 3. Slotted Set Screw]

5.2. Main PCB Configuration

■ After detaching the cover, the Main PCB terminal layout appears as shown in the figure below.

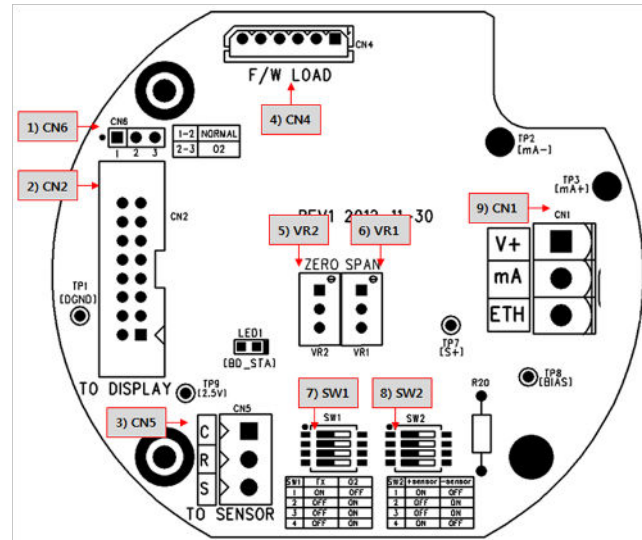

[Figure 4. Main PCB Key Layout]

No	NAME	DESCRIPTION
1	CN6	Program download Connector
2	CN2	Display Module Connector for Status Display
3	CN5	Sensor Connector
4	CN4	Program download Connector
5	VR2	Potentiometer for ZERO Output Adjustment
6	VR1	Potentiometer for SPAN Output Adjustment
7	SW1	Sensor Configuration Switch1 (Factory Setting)
8	SW2	Sensor Configuration Switch2 (Factory Setting)
9	CN1	Power & Output Signal Terminal

[Table 2. Main PCB Key Part Description]

5.3. Power and Signal Terminal Configuration

■ After disassembling display parts, there is a terminal block in the Main PCB as shown in the figure below. Holding it with hands and pulling towards ceiling detaches it from the Main PCB.

■ Loosen 5 terminal fixing screws located at top part of detached terminal block CN8 (VIS, +, mA, -, ETH) Connector by turning counter-clockwise using a Θ driver. Connect DC 18~24 V power to +, and - then connect signal cable to mA. Tighten 5 terminal fixing screws clockwise (cw) so that terminal does not leave the track then insert Main PCB as the same condition before disassembly.

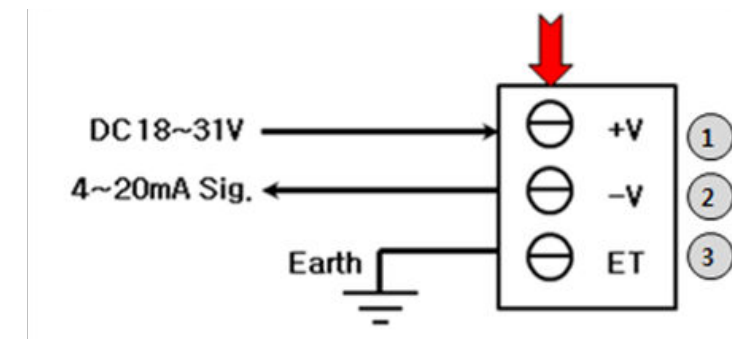

[Figure 5. CN1 Terminal Configuration]

NO	PIN NAME	DESCRIPTION
1	+V	+24V / POWER (+)
2	-V	4~20mA Source Out
3	ET	EARTH

[Table 3. CN1 Terminal Detailed Description]

■ Use CVVS or CVVSB 2.0sq \uparrow Shield Cable for terminal configuration.

5.4. Method to Connect to External Control Unit

- Connect 18 V~31 V DC operation power to CN1 (+, mA, -, ET) Connection Terminal of the gas detector then connect a device that can receive 4~20 mA signals to mA.

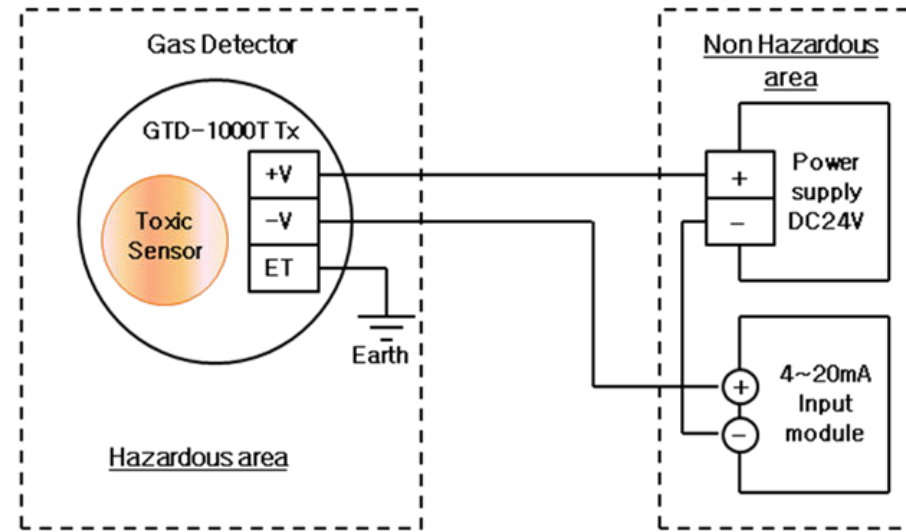

[Figure 6. External Control Unit Connection Method]

5.5. Installation Cable Length

- The maximum length between GTD-1000Tx(2W) and power supply is decided by wire specification.
- Max. Installation Length = $V_{MAXDROP} \div I_{MAX} \div WIRER/m \div 2$
 - VMAXDROP: Maximum Power Loop Voltage Drop (=Power Supply voltage - min operating voltage)
 - IMAX : Max. Current of GTD-1000Tx
 - WIRER/m: The resistance of the wire (ohms/meter value available in wire manufacturer's specification data sheet)
- Example of installation lengths using 24 V power supply and 16 AWG is as follows.
 - GTD-1000Tx(2W) minimum operating voltage = 16 Vdc
 - VMAXDROP = $24 - 16 - 5.5 = 2.5V$
 - IMAX = 0.022A(22mA)
 - $2.5 \div 0.022 \div 0.01318 \div 2 = 4,310.9m \approx 4310m$

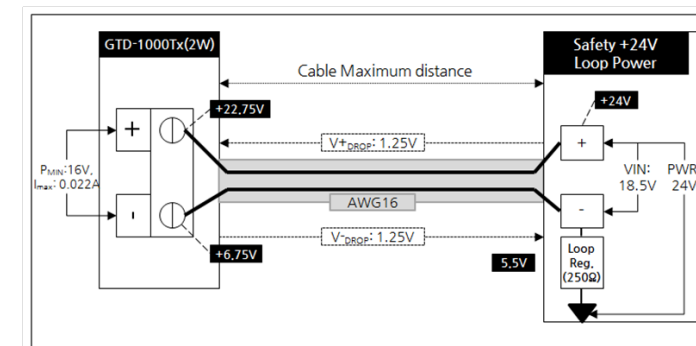

[Figure 7. Calculation of GTD-1000Tx(2W) Installation Cable Length]

- Power cable installation for each cable type is as shown in the table below.

AWG	mm2	COPPER RESISTANCE(ohms/m)	METERS
12	3.31	0.00521	10905
14	2.08	0.00828	6862
16	1.31	0.01318	4310
18	0.82	0.02095	2712
20	0.518	0.0333	1706

[Table 4. GTD- 1000Tx Power Cable Installation Length]

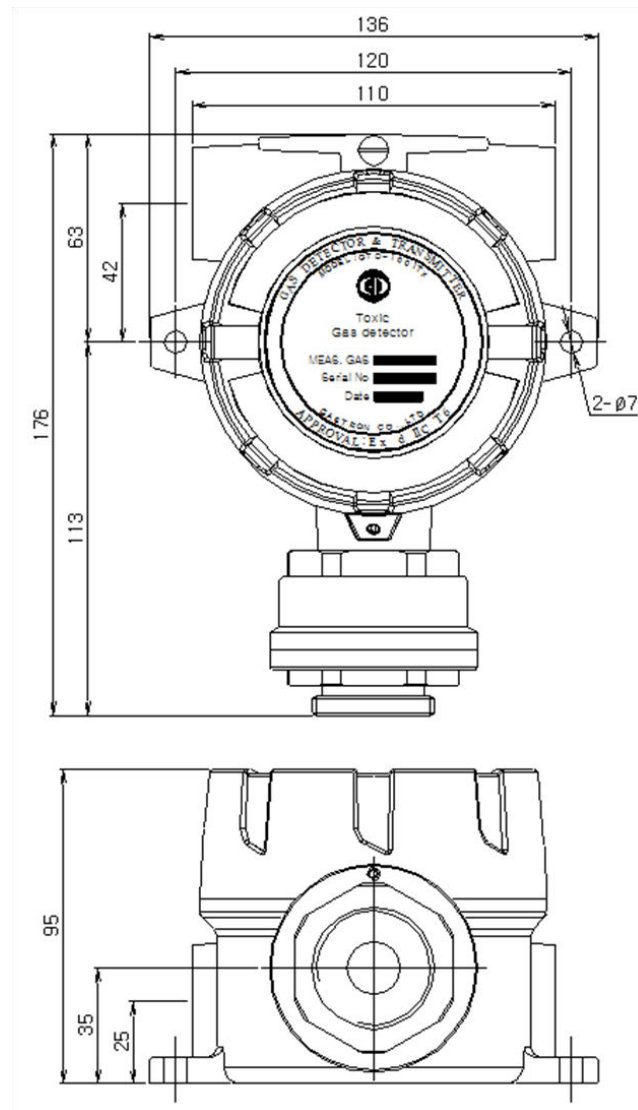

[Figure 11. GTD-1000Tx(2W) Drawing]

8.1. Selecting a Place for Installation (Occupational Health & Safety Data)

A gas leak detector alarm shall be installed in the following places.

- Around chemical equipment and accessories that have concerns of gas leak. This includes compressors, valves, reactors, pipe joints, etc. installed inside and outside of a building that handle combustible and toxic materials.
- Places that are easier for gases to stay such as areas around manufacturing facilities with ignition sources like heating furnace, etc,
- Areas around equipment for filling combustible and toxic materials.
- Substations, panel rooms, control rooms, and etc. located within explosive area.
- Other areas that are easier for gases to stay.

8.2. Selecting a Site for Installation (High-Pressure Gas Safety Act Data)

Gas detector of gas leak detector alarm must be installed as close to the areas with concerns of gas leakage as possible. However, for areas where direct gas leakage is not expected but are easier for leaked gas to stay, the detector must be installed at the point 1 of the following.

- Gas leak detector alarm installed outside a building shall be installed at points where gas is likely to stay in consideration to wind direction, wind speed, specific gravity of gas, etc.
- Gas leak detector alarm installed inside a building shall be installed near the floor when the specific gravity of gas is heavier than air and near ventilation of ceiling when it is lighter than air.
- Alarm for gas leak detector alarm must be installed at sites where the gas detector is installed and workers are present.

8.3. Precautions during Installation

Avoid areas with electrical barriers such as rain water, etc. It is recommended to be installed in areas that are easier to work in since regular maintenance is needed. Avoid areas with vibration or shock since they can affect output values. Sensor part must be installed towards the direction of gravity.

- This equipment has explosion-proof construction for internal pressure and belongs to GROUP II for gas and vapor in general work sites and chemical plants. It can be used in ZONE 1 (ONE) and ZONE 2 (TWO) hazardous sites.
- Allowable temperature is 85 C or below, which corresponds to T6.

- Use with surrounding temperature in a range of -20 C ~ 50 C.
- Installation Height: 1,000 M below sea level
- Relative Humidity: 5% ~ 99%
- Installation Site: Indoor and Outdoor
- Explosion Ignition Grade for the Gas or Vapor: Ex d IIC T6
- During wiring work, use explosion-proof cable gland at cable inlet or tightly seal cable conduit during metal cable wiring construction to prevent spread of flames in case of explosion or movement of gas, etc. through the cable conduit within 50 mm. All materials including materials used for sealing of unused inlets must have safety certificates!
- When connecting the equipment with cable, screw thread must be tightened 5 threads or more.
- Work in conditions satisfying other [Standards for Selection, Installation, and Maintenance, etc. of Explosion-proof Electric Machine and Equipment Wiring, etc. at Work Site]
- All materials used for cable inlet such as cable gland and sealing fitting, etc. and used as sealing unused inlets must pass the verification!

VERSION	CONTENTS	DATE
0.0	* Manual Initial Revision	2013.06.09
1.0	* Gas calibration method changed	2014.09.19
2.0	* mA Calibration Mode added	2014.10.24
3.0	* Changed Font	2014.12.26
4.0	* Separated Factory mode manual	2016.09.27
5.0	* Changed Explosion-proof Equipment Cable Entry Installation Regulation 45 cm → 50 mm	2017.01.20

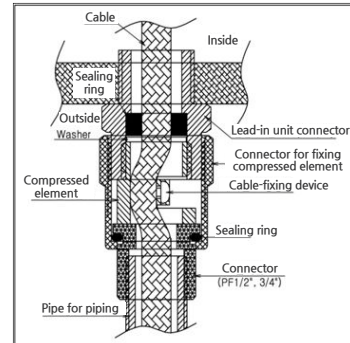

[Figure 12. High-Pressure Packing Type]

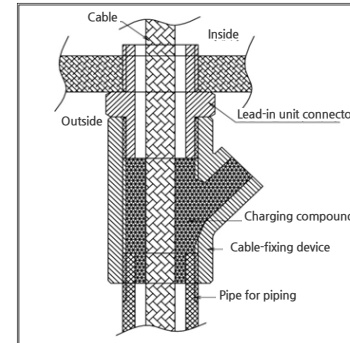

[Figure 13. Y Sealing Compound]