



Headquarters / Engineering research laboratory :
23 Gunpo Advanced Industry 1-ro(Bugok-dong), Gunpo-si, Gyeonggi-do
Tel +82-31-490-0800 Fax +82-31-490-0801

Yeongnam business office / Plant :
55 Gonghangap-gil 85beon-gil, Gangseogu, Busan Metropolitan City
Tel +51-973-8518 Fax +51-973-8519

E-mail : info@gastron.com

www.gastron.com

GTD-1000Tx(M)

Instruction Manual



Read in detail for correct use.

Gas & Flame Detection System

GASTRON



When abnormalities occur after purchasing the product, please contact the following address.

- Address : 23 Gunpo Advanced Industry 1-ro, Gunpo-si, Gyeonggi-do
- Tel : 031-490-0800
- Fax : 031-490-0801
- URL : www.gastron.com
- e-mail : info@gastron.com

We sincerely thank you for purchasing the product of Gastron Co. Ltd.

Our Gastron Co.Ltd. is a company specialized in Gas detector and Gas Monitoring System, being recognized by many consumers due to the best quality and use convenience. We always enable you consumers to find desired products nearby and are ceaselessly studying and striving for development of Gas detectors satisfying customers. From now on, solve all anguishes concerning Gas detector with the products of Gastron Co. Ltd, We Gastron Co. will take a responsibility and give you satisfaction.

In the present instruction manual, operation method for Gas detector as well as simple methods for maintenance and repair, etc. are recorded. If you read it in detail and keep it well, for reference when you have questions, then it will give you much help.

- For accurate operation of Gas detector, check up and calibrate for more than once in every 6 months. (* In reference to KOSHA GUIDE: P-135/6-2018 / 7.2 In-house inspection, section 2)
- For accurate operation of Gas detector, checkup and calibration with calibration gas before measurement is recommended.
- When not calibrated, it may cause malfunction of the equipment due to problems resulting from Sensor aging.
- When the present instrument should be dismantled, those with professional skills for Gas detector should conduct the operation.
- For power supply cable, wire specifications should be determined by referring to the item of "Length of installed cable".
- For the contents on checkup and calibration of Gas detector, please use our company's engineering department , e-mail, or web site.

The present product and the product manual can be changed without advance notice for performance improvement and use convenience of the product.

* KOSHA GUIDE : P-135/6-2018

Calibration must be performed at a frequency requested by the manufacturer and shall be performed quarterly when the calibration period is not specified.

1. Overview	6		
2. Configuration	6		
3. Specification	7		
3.1. Basic Specifications	7		
3.2. Mechanical Specifications	7		
3.3. Electrical Specifications (Standard Type)	8		
3.4. Environmental Specifications	8		
4. Name and Description of Each Part	9		
4.1. Components	9		
5. Installation	11		
5.1. Detachment of Housing Cover	11		
5.2. Main PCB Configuration	12		
5.3. Terminal Configuration	13		
5.3.1. Wiring for 4~20mA Source Operation Type	14		
5.3.2. Wiring for 4~20mA Sink Operation Type	14		
5.3.3. Wiring for 4~20mA 3Wire Sink Operation Type	15		
5.4. Installation Cable Length	15		
6. Detector Operation Flow	17		
6.1. Initial Operation Status (Power On)	17		
6.2. Measuring Mode	17		
6.3. Operation Flow	18		
6.4. Menu Configuration Table	19		
7. System Mode	20		
7.1. PROGRAM MODE	20		
7.2. CALIBRATION MODE	21		
		7.2.1. Zero Calibration	21
		7.2.2. Span Calibration	22
		7.3. ALARM Mode	23
		7.4. Device Mode	24
8. Troubleshooting	25		
8.1. Fault List	25		
8.2. Recovery List	25		
9. Interface Configuration	26		
9.1. MODBUS RS485	26		
9.1.1. Interface setting	26		
9.1.2. MODBUS RS485 Register map	26		
10. Drawings and Dimensions	27		
10.1. Standard Type	27		
11. Precautions before Installation	28		
11.1. Selecting a Place for Installation (Occupation Safety and Health Act Data)	28		
11.2. Selecting a Site for Installation (High-Pressure Gas Safety Control Act Data)	28		
11.3. Precautions during Installation	28		
12. Revision History	30		

GTD-1000Tx(M) toxic gas detector has been developed to detect gas leaked from industrial sites and various toxic gases generated from factories, gas storages, and manufacturing processes that produce or use toxic gases and to prevent accidents in advance.

GTD-1000Tx(M) toxic gas detector is installed in areas with gas leak hazards and continuously monitors gas leak. It provides DC 4-20 mA standard output signal and RS-485 network signal. Also, DC 4~20 mA standard output enables transmission distance of the output signal between detector and receiver at maximum 2,500 m (when using cables with CVVS or CVVSB 1.5 sq or higher). RS-485 network signal can be transmitted up to 1,000 m (when using a designated cable for RS-485). GTD-1000Tx(M) toxic gas detect must be used at a height below 1,000 m above sea level.

2. Configuration

Body of GTD-1000Tx(M) is made of Aluminum alloy and the gas sensor module is made of stainless steel. It consists of a complete explosion-proof enclosure (Ex d IIC T6). This product can be installed in all areas prone to toxic gas leak and explosion hazards.

Internal configuration consists of 1 terminal PCB board that outputs measurements externally (DC 4-20 mA, RS-485).

External configuration consists of detector part that monitors gas leak and cable inlets.

It can perform calibration using detachable display (LCD or OLED), therefore maintenance is convenient.

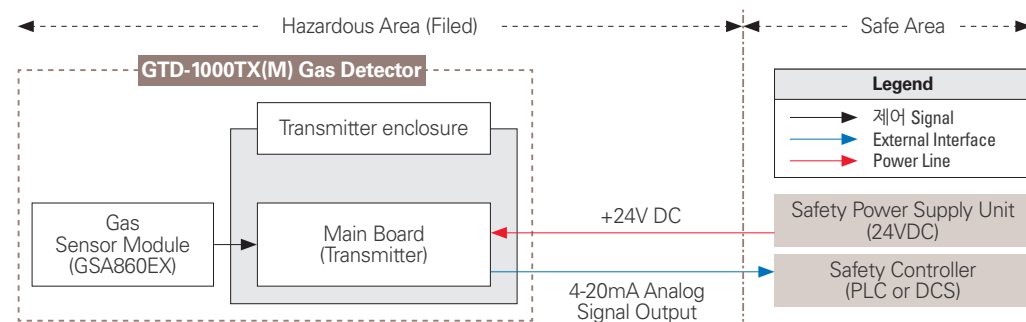

[Figure 1. GTD-1000Tx(M) Overview]

3.1. Basic Specifications

ITEMS	SPECIFICATION	
Measuring Type	Diffusion	
Measuring Method	- Electro-Chemical Cell - Heated-semiconductor Cell - Photoionization detector(PID)	
Detectible Gas	Toxic Gas (Note1)	
Measuring Range	Capable to display 000.0 ~ 10000 (Note 1)	
Accuracy	≤ ±3% / Full Range	
Zero Drift	≤2% / Full Range	
Response Time	Depends on Sensor Module. Refer to Sensor Specification or Contact in case for Special Gas.	
Approvals Classification)	KCs: Ex d IIC T6,T5,T4, IP65	
Basic Interface	Analog 4-20mA current interface	
Rs-485 Interface	RS-485 MODBUS (Option)	
Option	RS-485 Board	
	GTL-100 Warning Light	
	Rain Cover	
Warranty	Transmitter	2Year
	Sensor	1Year

※ Note1. Refer to the measured gas list for measured gases and their ranges. Contact us for special gas.

3.2. Mechanical Specifications

ITEMS	SPECIFICATION	
Eexplosion Proof type	Explosion-proof enclosure	
Dimension	136(W) × 176(H) × 95 (D) mm	
Weight including Sensor	App. 1.5kg	
Mounting type	Wall mount	
Mounting Holes	Ø 7 ±0.1	
Cable inlet	3/4" PF (1/2" or 3/4" NPT)	
Body material	Transmitter	aluminum alloy
	Sensor	Stainless Steel (STS316)

3.3. Electrical Specifications (Standard Type)

ITEMS	SPECIFICATION	
Input Voltage(Standard) ※ Customer supplied PSU must meet requirements IEC1010-1 and CE Marking requirements.	Absolute min: Nominal: Absolute max: Ripple maximum allowed:	18V 24V 31V 1V pk-pk
Wattage	Max. wattage: Max. current:	3.6W @+24 VDC 150mA @+24 VDC
Analog output Current	0-20mA(500 ohms max load) All readings ± 0.2mA Measured-value signal: 4mA(Zero) to 20mA(Full Scale)	
	Fault: 0-100% LEL: 100-109%LEL: Over 110% LEL: Maintenance:	0mA 4mA - 20mA 20mA - 21.4mA 22mA 3mA
Analog output current ripple & noise max	±20uA	
Wiring requirement	Power	CVVS or CVVSB with shield
	Analog	CVVS or CVVSB with shield
Cable Connection Length	Analog	2500m
	RS-485	1000m
EMC Protection:	Complies with EN50270	

3.4. Environmental Specifications

ITEMS	SPECIFICATION	
Operation Temperature	Transmitter	-20 to 50 °C
	Sensor	Refer to Sensor Specification
Storage Temperature	Transmitter	-20 to 50 °C
	Sensor	Refer to Sensor Specification
Operation Humidity	Transmitter	5 to 99% RH (Non-condensing)
	Sensor	Refer to Sensor Specification
Pressure Range	90 to 110KPa	
Max. air velocity	6m/s	

4.1. Components

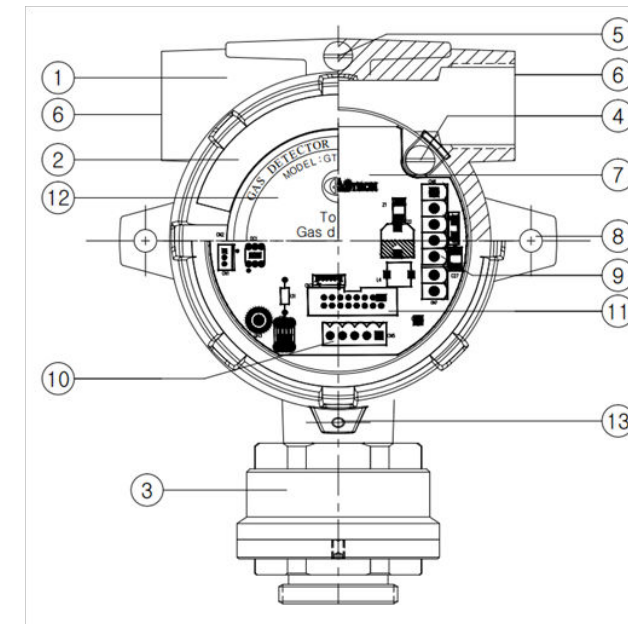

[Figure 2. GTD-1000Tx(M) Components]

NO	NAME	DESCRIPTIONS
1	Housing Body	Protects PCB Board built in Sensor and Housing from external environmental change and shock.
2	Housing Cover	It is assembled with detector housing body and protects PCB Board built in Sensor and Housing from external environmental change and shock
3	Sensor	It is a site that detects actual gas leak. It converts the amount of gas leak into electrical signal and transmits to the Main PCB.
4	Internal Ground	It must be grounded to inside of detector for protection from external noise or strong electric field. - Use a conductor that is 4 mm or longer when coupling ground line.
5	External Earth Ground	It must be grounded to outside of detector for protection from external noise or strong electric field. - Use a conductor that is 4 mm or longer when coupling ground line.
6	Conduit Connection	It is supplied for inlet of power supply and measurement output signal for the detector during installation. For cable inlet, PF or NPT 1/2", 3/4" are prepared.
7	Main PCB	Amplifies fine outputs generated from Sensor Element to transmit a converted output in 4~20 mA DC standard. It sends data to display part.
8	Mount Hole	Hole to fix the gas detector on external wall or other installation sites.

No	ITEMS	SPECIFICATION
9	Power/Signal Terminal	CN6 consists of DC 24 V power supply and DC 4~20 mA standard output connection terminal (VISO, +24V, mA, GND, ETH). CN7 is RS-485 Modbus network terminal.
10	Sensor Terminal	CN5 is Sensor Connection Terminal.
11	Display Terminal	CN5 is a terminal that connects to display board. Display board is attached for test and calibration.
12	Model Name Plate	It displays product's model name, measuring gas, and serial number, etc.
13	Set Screw(M4-L6)	It is a set screw that prevents cover opening from the detector housing body.

[Table 1. GTD-1000Tx(M) Components Description]

- It is prohibited for an individual, other than an approved user or a technician responsible for installation and repair from the head office, to install a gas leak sensor on site or open the cover of the installed gas leak sensor and manipulate it. This may cause serious loss of life and property from fire, explosion, and etc. In addition, please check whether there is any remaining explosive gas or combustible material in the surroundings. Power must be turned off before performing work.

5.1. Detachment of Housing Cover

- <Warning - Do not open when electrical current is flowing>
- Turn the slotted set screw (M4 x 1ea) fixing the cover part of main body 3~4 tuns counter clockwise (ccw) using a hex wrench (M2) then turn the cover of gas leak detector ccw to detach the cover. When the cover is detached, LCD appears.

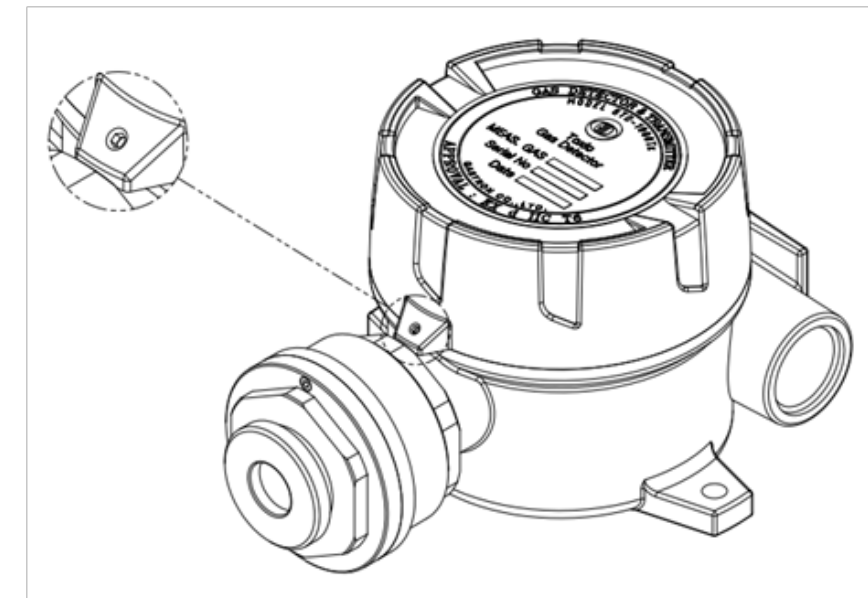

[Figure 3. Slotted Set Screw]

5.2. Main PCB Configuration

■ After detaching the display parts, the Main PCB terminal layout appears as shown in the figure below.

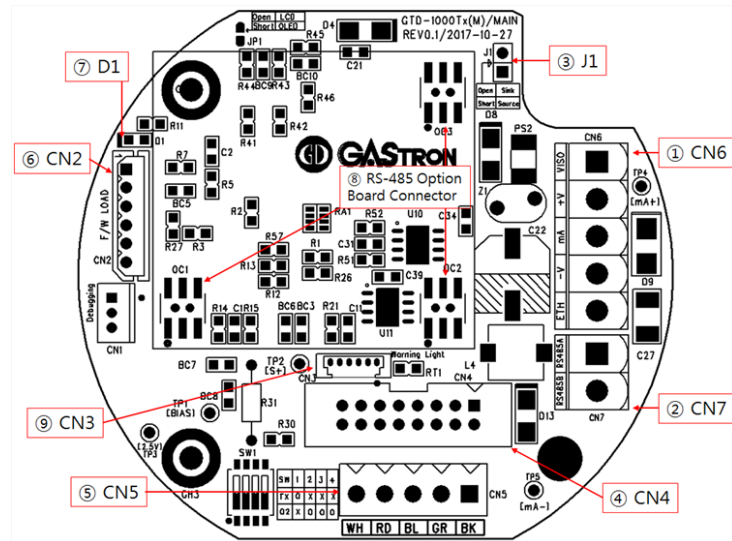

[Figure 4. Main PCB Terminal Layout]

No	NAME	DESCRIPTION
1	CN6	Power & Output Signal Terminal
3	CN7	RS-485 Terminal
3	J1	4~20mA Source / Sink Selection Jumper (ON: Source Type, OFF: Sink Type)
4	CN4	Display LCD Connector
5	CN5	Sensor Connector
6	CN2	Program download Connector
7	D1	Status LED (Flashes in 1 sec interval during normal operation)
8	OC1,OC2,OC3	RS-485 Option Board Connector
9	CN3	Warning light (GTL-100) Interface Connector

[Table 2. Main PCB Key Part Description]

■ Using OC1, OC2, and OC3 shown in the layout above, RS-485 option board can be attached and 3ØScrew holes located at top left of RS-485 option board are used for fixing.

5.3. Terminal Configuration

■ <Warning - Turn off power before connecting power terminal>

■ Loosen 5 terminal fixing screws located at top part of detached terminal block CN6 (VIS, +, mA, -, ETH) Connector by turning counter-clockwise using a Ø driver. Connect DC 18~24 V power to +, and - then connect signal cable to mA. Tighten 5 terminal fixing screws clockwise (cw) so that terminal does not leave the track then insert Main PCB as the same condition before disassembly.

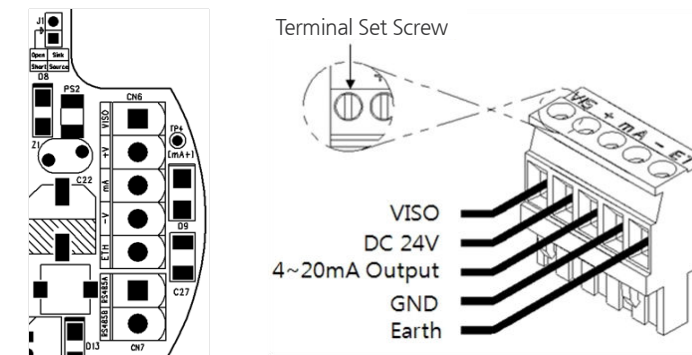

[Figure 5. CN6, CN7 Terminal Configuration]

NO	PCB SILK	PIN NAME	DESCRIPTION	
			4~20mA Source Drive (J1 Jumper ON)	4~20mA Sink Drive (J1 Jumper OFF)
1	VISO	VIS	N.C	4~20mA Sink In(+)
2	+24V	+	+24V / POWER (+)	
3	mA	mA	4~20mA Source Out	4~20mA Sink Out(-)
4	GND	-	GND / POWER (-)	
5	ETH	ET	EARTH	

[Table 3. CN6 Terminal Detailed Description]

■ Use CVVS or CVVSB 2.0sq Shield Cable for terminal configuration.

NO	PCB SILK	DESCRIPTION
1	RS485A	RS485A Terminal
2	RS485B	RS485B Terminal

[Table 4. CN7 Terminal Detailed Description]

5.3.1. Wiring for 4~20mA Source Operation Type

- Connect 4-20 mA signal terminal at PLC side to 'mA' of GTD-1000Tx(M). GND terminal is used in common with power. Then, turn on the J1 jumper.

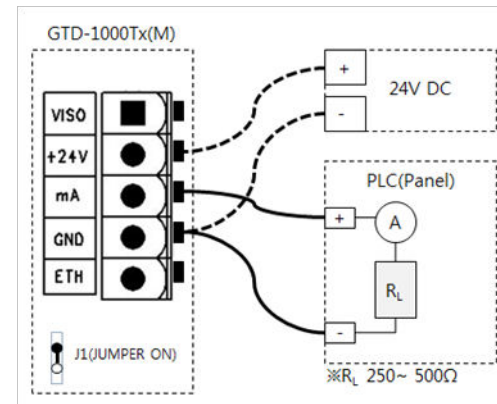

[Figure 6. 4-20mA Source Configuration]

5.3.2. Wiring for 4~20mA Sink Operation Type

- Connect (+) and (-) terminals for 4-20 mA sink output at PLC side to VISO terminal and 'mA' terminal, respectively. Then, turn off the J1 jumper.

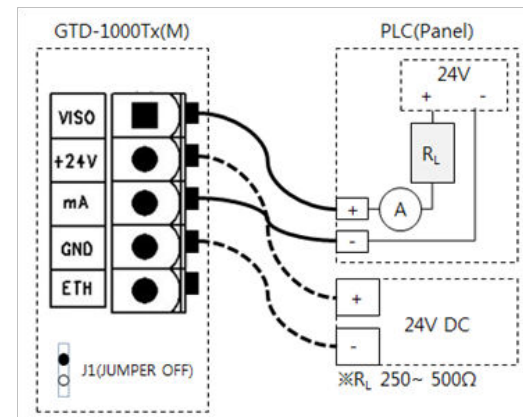

[Figure 7. 4-20mA Sink Configuration]

5.3.3. Wiring for 4~20mA 3Wire Sink Operation Type

- Connect (+) and (-) terminals for 4-20 mA sink output at PLC side to VISO terminal and power (24V DC) (-) terminal, respectively. Connect 'mA' terminal of GTD-1000Tx(M) to 'GND' terminal. Then, turn off the J1 jumper.

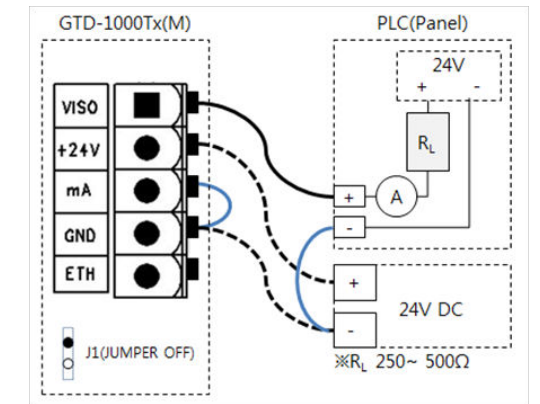

[Figure 8. 4-20mA 3Wire Sink Configuration]

5.4. Installation Cable Length

- The maximum length between GTD-1000Tx(M) and power supply is decided by wire specification.
- Max. Installation Length = $V_{MAXDROP} \div I_{MAX} \div WIRER/m \div 2$
 - VMAXDROP: Maximum Power Loop Voltage Drop (=Power Supply voltage - min operating voltage)
 - IMAX : Max. Current of GTD-1000Tx(M)
 - WIRER/m: The resistance of the wire (ohms/meter value available in wire manufacturer's specification data sheet)
- Example of installation lengths using 24 V power supply and 16 AWG is as follows.
 - GTD-1000Tx(M) minimum operating voltage = 18 Vdc
 - VMAXDROP = 24 - 18 = 6V
 - IMAX = 0.15A (150mA)
 - $6 \div 0.15 \div 0.01318 \div 2 = 1,517.451m \approx 1,517m$

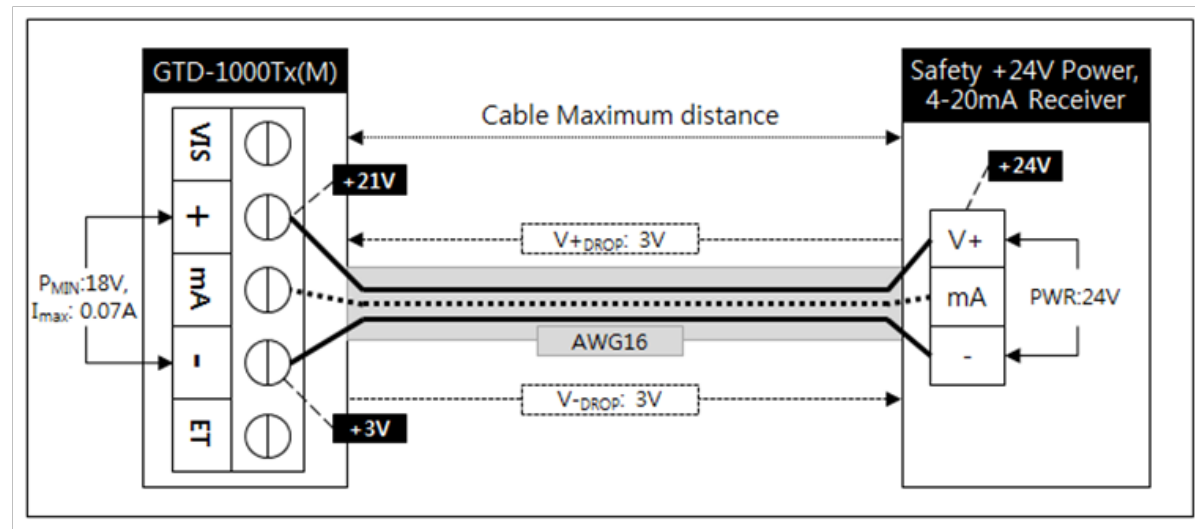

[Figure 9. Calculation of GTD-1000Tx(M) Installation Cable Length]

■ Power cable installation for each cable type is as shown in the table below.

AWG	mm ²	COPPER RESISTANCE(ohms/m)	METERS
12	3.31	0.00521	3838
14	2.08	0.00828	2415
16	1.31	0.01318	1517
18	0.82	0.02095	954
20	0.518	0.0333	600

[Table 5. GTD- 1000Tx(M) Power Cable Installation Length]

Display board is connected and used during maintenance and repair. For normal display operation after connecting in operation status, contact 'RESET' key.

6.1. Initial Operation Status (Power On)

■ After wiring to power terminal at the top of Main PCB board then supply power, the following contents are displayed on LCD. Approx. 30 min of stabilization of time is needed from the initial supply of operation power and it starts to operate normally after sufficient stabilization.

GTD-1000 [V X.XX]	- When power turns on, model name and product firm ware version are displayed on LCD.
SELF TEST [>>>>0179]	- Self test is performed for 3 min (30 min for O2 set-up), '>' symbol in the second row shows the progress.

6.2. Measuring Mode

■ After power on, when there is no error from "SELF TEST", it automatically enters Measuring Mode.

[%LEL] [0.0]	- In normal operation mode, it runs as below. - In the first row, measured gas name and unit are displayed in 1 sec interval. In the second row, the current measurement is displayed.
[COMB.] [0.0]	- In the current screen, touching the magnet-bar on 'Func' key for 2 sec or longer changes to setting mode. ※ During Modbus network, '*' is displayed on the left of the first row. ※ ENG. When the mode is on, '<' is displayed on the left of the second row.
[%LEL] [30]	- When alarm1 or 2 occurs, it runs as below. (It runs only when alarm used setting in alarm mode is on.) - The first row runs the same as in normal status. In the second row, alarm message and gas measurement are displayed in 1 sec interval.
[%LEL] [ALARM1]	- When GTL100 explosion-proof warning light is installed, upon an event of alarm1, red LED and buzzer flicker and run in 1 sec interval. Upon an event of alarm2, they continuously run without flickering. - If alarm latch is on, the alarm continuously run until it is released using the reset key.
[%LEL] [OVER]	- When gas measurement larger than 10% of set high scale value, "OVER" displays in 1 sec interval. At this time, 4~20 mA runs as 22 mA.
[%LEL] [UNDER]	- When gas measurement smaller than -10%, "UNDER" displays in 1 sec interval and 4~20 mA runs below 2 mA. ※ The following function only runs when UNDER is on.
[FAULT8] SEN HUNT	- When trouble occurs in the device, it displays fault number and message. - At this time, 4~20 mA runs below 2 mA. - Fault #8 on the left is a mode that is displayed when there is repeated hunting error from the sensor.

6.3. Operation Flow

- After power on, it passes self-diagnostic process then enters Measuring Mode. Here, by operating front keys, you can go to internal System Mode.
- Timeout for Level1 and Level2 are 10 sec. It is set to 1 h for Level2 Calibration and Test Mode.
- When "RESET" key contacts at Program Mode Screen, it returns to Measuring Mode. When "RESET" key contacts at each Program Setting Screen, it returns to the parent step.

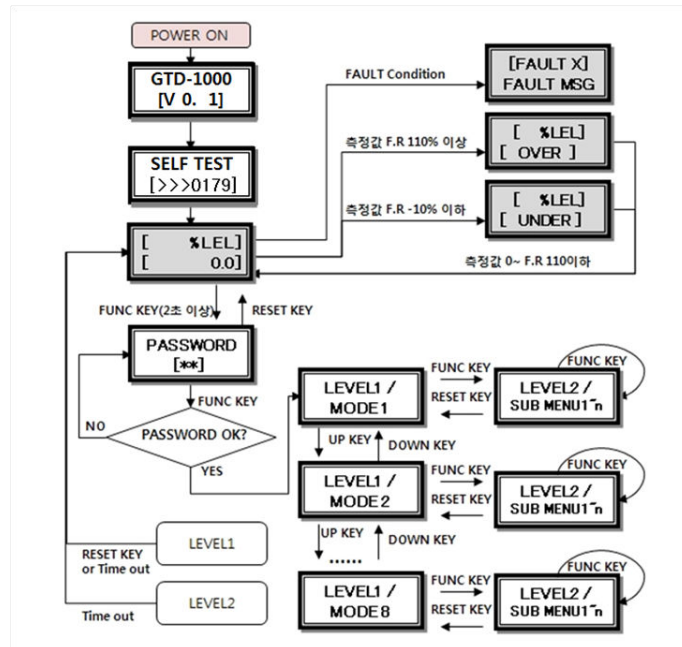

[Figure 10. GTD-1000Tx(M) Mode Configuration]

- Operation keys for detector system mode are defined as below.

ITEM	NAME	DESCRIPTION
FUNC	Function key	Detector Mode Setting Entry Function (Insert Magnetic-bar for 2 sec or longer in measuring mode) Level2 Next stage entering function and setting saving function
RESET	Reset key	Move to the previous stage from the level entered.
↑	Up key	Next level mode that is configured in LEVEL1 and Change in Level2 setting Plus
↓	Down key	Next level mode that is configured in LEVEL1 and Change in Level2 setting Minus

6.4. Menu Configuration Table

LEVEL1	LEVEL2		DEFAULT
	NAME	PARAMETER	
PROGRAM MODE	GAS TYPE (Gas Type)	[DEFIN./USER]	DEFIN.
	GAS SEL (Gas Select)	Built-in gas name selection	COMB.
	UNIT SEL (Unit Select)	%/%LEL/PPM/PPB	%LEL
	D-POINT (Decimal Point)	0.100/1.00/10.0/100	100
	HIGH SCL (High Scale)	1~10000	100
	PASSWORD	00~99	00
CALIBRA. MODE (Calibration Mode)	CALIBRA. [ZERO] (Calibration Zero)	ZERO CAL [NO, YES]	[NO]
		ZERO GAS [0]	
		ZERO >>>> [SUCCESS / FAIL]	
	CALIBRA. [SPAN] (Calibration Span)	CAL. DATA [0/ FAIL]	
		SPAN CAL [NO, YES]	[NO]
		SPAN GAS [0]	
	SPAN SET [50/ FAIL]	50	
	SPAN >>>> [SUCCESS / FAIL]		
	CAL. DATA [0]		
ALARM MODE	ALM USED (Alarm Used)	[OFF / ON]	OFF
	AL LATCH (Alarm Latch)	[OFF / ON]	OFF
	A1 LEVEL (Alarm-1 Level)	[1 ~ 10000]	20
	A1 TYPE (Alarm-1 Type)	[INC / DEC]	INC
	A1 DBAND (Alarm-1 Dead Band)	[0.0 ~ 10.0%F.S]	0
	A1 TIME (Alarm-1 Time)	[0~ 60]SEC	1
	A2 LEVEL (Alarm-2 Level)	[1 ~ 10000]	40
	A2 TYPE (Alarm-2 Type)	[INC / DEC]	INC
	A2 DBAND (Alarm-2 Dead Band)	[0.0 ~ 10.0%F.S]	0
	A2 TIME (Alarm-2 Time)	[0~ 60]SEC	1
DEVICE MODE	485 B/D ADDRESS	[CHECK / EMPTY]	
		[0 ~ 64]	[1]
SENSOR MODE		Factory Setting	
MAINTEN.MODE		Factory Setting	
VERSION MODE		Factory Setting	
TEST MODE		Factory Setting	

7.1. PROGRAM MODE

PASSWORD [**]	- Contacting "FUNC" key for 2 sec or longer in Measuring Mode enters Password mode. - After setting Password using "↑" or "↓" key, contact "FUNC" key.
PROGRAM MODE	- If password is correct, it enters Program mode. - By contacting "↑" or "↓" key, mode changes in defined order. (PROGRAM -> CALIABRA. -> ALARM -> SENSOR -> MAINTEN. ->DEVICE -> VERSION -> TEST)
GAS TYPE [DEFIN.]	- Mode that sets gas name type and contacting "↑" or "↓" key changes gas type. (DEFIN. / USER) - DEFIN. Is acronym for Define and is selected when using built-in setting of gas name. USER is selected when the user directly sets a gas name. - When a desired gas type is displayed, contact "FUNC" key to set the gas name and enter Program Mode.
GAS SEL [COMB.]	- Mode that sets gas name and contacting "↑" or "↓" key changes gas name. - When gas type is set to DEFIN., built-in gas names can be selected for use. When it is set to USER, the user shall set gas name using 5 character for use. Characters allowed for use are number, capital Alphabet, space, and period. When position is moved by setting characters, a cursor in black box shape appears as shown in the figure on left.
USER GAS [■]	
UNIT SEL [%LEL]	- Mode that sets gas measuring unit and contacting "↑" or "↓" key changes gas measuring unit. (% / %LEL / PPM / PPB). - When a desired gas measuring unit is displayed, contact "FUNC" key to set the unit and enter Program Mode.
D-POINT [100]	- Mode that changes decimal place and contacting "↑" or "↓" key changes decimal place. (0.100/1.00/10.0/100) - When a desired decimal place is displayed, contact "FUNC" key to set the decimal place and enter the next Program Mode.
HIGH SCL [100]	- Mode that sets high scale value that should be displayed for full range. Contacting "↑" or "↓" key increases or decreases the scale value. (1 ~ 10000) - When a desired high scale is displayed, contact "FUNC" key to set the high scale value and enter the next Program Mode.
PASSWORD [00]	- It is password setting mode. This password is checked when entering Program Mode. - Set using "↑" or "↓" key then contact "FUNC" key to set the password and enter the next Program Mode.

7.2. Calibration Mode

- Due to characteristics of the gas detector, minimum 30 min of stabilization time is required and maintenance condition may change depending on site condition..

7.2.1. Zero Calibration

PASSWORD [**]	- Contacting "FUNC" key for 2 sec or longer in Measuring Mode enters Password mode. - After setting Password using "↑" or "↓" key, contact "FUNC" key.
CALIBRA. MODE	- Contact "↑" or "↓" key to select "Calibration Mode". - Contact "FUNC" key when "CALIBRA. MODE" is displayed to enter Calibration Mode. - Contact "RESET" key to return to Measuring Mode.
CALIBRA. [ZERO]	- When "CALIBRATION MODE" is displayed, contacting "FUNC" key selects Zero Calibration. - Contact "↑" or "↓" key to achieve [ZERO] then contact "FUNC" key to enter Zero Calibration.
ZERO CAL [NO]	- Contact "↑" or "↓" key to achieve [YES] then contact "FUNC" key to perform Zero Calibration.
ZERO GAS [0]	- Using a calibration tool, inject clean air or 100% nitrogen into the sensor at a flow rate of 500 mL/min for 1 min. Contact "FUNC" key when measurement is stabilized to automatically perform Zero Calibration.
ZERO >> [SUCESS]	- When zero calibration is successful, "ZERO SUCCESS" is displayed for 2 sec on LCD display then it changes to "CALIBRATION DATA" Mode.
ZERO >> [FAIL]	- When zero calibration is not successful, "ZERO FAIL" is displayed for 2 sec and it changes to "CALIBRATION DATA" Mode. - ZERO FAIL occurs when sensor input value exceeds 70% of total ADC input range.
CAL.DATA [0]	- It is a mode to display measurement after calibration and checks whether calibration is successful after performing auto calibration. - When it failed, it displays "FAIL" and the current measurement in 1 sec interval. - Contact "RESET" key to return to "Calibration mode".

7.2.2. Span Calibration

CALIBRA. MODE	- Contact "↑" or "↓" key to select "Calibration Mode". - Contact "FUNC" key when "CALIBRA. MODE" is displayed to enter Calibration Mode.
CALIBRA. [SPAN]	- Contact "↑" or "↓" key to achieve [SPAN] then contact "FUNC" key to enter Span Calibration mode.
SPAN CAL [NO]	- Contact "↑" or "↓" key to achieve [YES] then contact "FUNC" key to perform Span Calibration.
SPAN GAS [50]	- Using a calibration tool, inject the standard gas to the sensor at a flow rate of 500 mL/min for 90 sec. After the measurement is stabilized, contact "FUNC" key to enter the next mode. - When Hold function in Maintenance Mode is on, the current maximum SPAN gas value is held and displayed in the first row.
[50] [50]	- The current measurement is displayed in the second row.
SPAN SET [50]	- It is a mode to set standard gas value. When there is no "Fail" message, contact "↑" or "↓" key to set a value. - When the inject standard gas value is abnormal, it displays Fail message. Fail message is as follows. Fail message and span set value are displayed alternatively.
SPAN SET LOW FAIL	① "LOW FAIL" occurs when the difference between injected gas value and zero calibration value is below 1%.
SPAN SET HIGH FAIL	② " HIGH FAIL" occurs when injected gas value is above 95% of total ADC input range. - "RING FAIL" occurs when injected gas value runs in the current set span value, it exceeds 95% of ADC input range. The above FAIL messages are automatically released if the status is normal after adjusting SPAN value.
SPAN >> [SUCCESS]	- After completing standard gas value setting, contacting "FUNC" key automatically runs Span Calibration. When it succeeds, "SPAN SUCCESS" is displayed on LCD display for 2 sec then it changes to "CAL DATA" Mode.
SPAN >> [FAIL]	- When span calibration is not successful, "SPAN FAIL" is displayed for 2 sec and it changes to "Cal. Data Mode".
CAL.DATA [0]	- It is a mode to display measurement after calibration and checks whether calibration is successful after performing auto calibration. - Contact "RESET" key to return to "Calibration mode".

7.3. ALARM MODE

PASSWORD [**]	- Contacting "FUNC" key for 2 sec or longer in Measuring Mode enters Password mode. - After setting Password using "↑" or "↓" key, contact "FUNC" key.
ALARM MODE	- Contact "↑" or "↓" key to select "Alarm Mode". - Contact "FUNC" key when "ALARM MODE" is displayed to enter Alarm setting mode. - Contact "RESET" key to return to Measuring Mode.
ALM USED [ON]	- It is a setting where Alarm Mode Setting is turned on or off. - Contact "↑" or "↓" key to change ON/OFF status. When it is ON, Alarm function and Alarm Mode setting can be performed. - GTL-100 explosion-proof warning light can only be used when it is ON. - Contacting "FUNC" key enters the next mode.
AL LATCH [ON]	- It is a mode that sets Reset method after running of Alarm1. Contact "↑" or "↓" key to change "ON" and "OFF". - "OFF" sets to automatically reset the alarm. "ON" set to reset the alarm only when Reset key is pressed. - Contact "FUNC" key when a desired mode is displayed to set then enter the next alarm setting mode.
A1 LEVEL [20]	- It is a mode that sets Alarm1 level. Contact "↑" or "↓" key to increase or decrease Alarm1 level, respectively. - When a desired alarm 1 threshold is displayed, contact "FUNC" key to set it and enter the next item.
A1 TYPE [INC]	- It is a mode that sets operational direction of Alarm1. Contact "↑" or "↓" key to display "INC" or "DEC". - "INC" mode operates when the value is equal or larger than set alarm threshold. "DEC" mode operates when the value is equal or less than set alarm threshold.
A1 TYPE [DEC]	- Contact "FUNC" key when a desired mode is displayed to set then enter the next mode.
A1 DBAND [0]%F	- It is a mode that sets Dead band value for Alarm1 operation. Use "↑" or "↓" key to set a value. - It is a function where Alarm1 operates at values above the sum of Alarm1 level and dead band values and releases at values below Dead band value subtracted from Alarm1 level. - When a desired alarm 1 dead band is displayed, press "FUNC" KEY to set it and enter the next item.
A1 TIME 0 SEC	- It is a function to prevent instantaneous malfunction of detector due to external shock and noise other than from normal operation and time can be set in a range between 0~60 sec. - For Alarm1 dwell time setting, press "↑" or "↓" key to increase or decrease in unit of 1 sec, respectively. - When a desired Alarm 1 dwell time is displayed, press "FUNC" KEY to set it and enter the next item. - Ex.) Alarm threshold value: 20% LEL / Delay time: When it is at 5 sec, Alarm triggers when the measured value is above the set value based on 20%LEL for 5 sec or longer. When it goes down below the set value within 5 sec, alarm is not triggered.
A2 LEVEL [20]	- It is a mode that sets Alarm2 level. Contact "↑" or "↓" key to increase or decrease Alarm2 level, respectively. - When a desired alarm 2 threshold is displayed, press "FUNC" KEY to set it and enter the next item.

A2 TYPE [INC]	- It is a mode that sets operational direction of Alarm2. Contact "↑" or "↓" key to display "INC" or "DEC".
A2 TYPE [DEC]	- "INC" mode operates when the value is equal or larger than set alarm threshold. "DEC" mode operates when the value is equal or less than set alarm threshold. - Contact "FUNC" key when a desired mode is displayed to set then enter the next mode.
A2 DBAND [0]%F	- It is a mode that sets Dead band value for Alarm2 operation. Use "↑" or "↓" key to set a value. - It is a function where Alarm2 operates at values above the sum of Alarm2 level and dead band values and releases at values below Dead band value subtracted from Alarm2 level. - When a desired alarm 2 dead band is displayed, press "FUNC" KEY to set it and enter the next item.
A2 TIME 0 SEC	- It is a function to prevent instantaneous malfunction of detector due to external shock and noise other than from normal operation and time can be set in a range between 0~60 sec. - For Alarm2 dwell time setting, press "↑" or "↓" key to increase or decrease in unit of 1 sec, respectively. - When a desired Alarm2 dwell time is displayed, press "FUNC" KEY to set it and enter the next item. - Ex.) Alarm threshold value: 40% LEL / Delay time: When it is at 5 sec, Alarm triggers when the measured value is above the set value based on 40%LEL for 5 sec or longer. When it goes down below the set value within 5 sec, alarm is not triggered.

7.4. Device Mode

PASSWORD [**]	- Contacting "FUNC" key for 2 sec or longer in Measuring Mode enters Password mode. - After setting Password using "↑" or "↓" key, contact "FUNC" key.
DEVICE MODE	- Contact "↑" or "↓" key to select "CALIBRA. MODE". When "DEVICE MODE" is displayed, contact "FUNC" key to enter Device Mode. - Contact "RESET" key to return to Measuring Mode.
485 B/D CHECK	- It is a setting where connection status of RS-485 Board is confirmed. - When it is connected, it displays CHECK. If not, it displays EMPTY.
ADDRESS [OFF]	- It is a setting where RS-485 Modbus Address is set. - Contact "↑" or "↓" key to change the address.
ADDRESS [1]	

8.1. Fault List

FAULT MESSAGE	DESCRIPTION & CONDITION	CAUSE
FAULT2 "SEN HIGH"	Sensor output is above ADC max. value.	Defective sensor module or transmitter board ADC
FAULT3 "SEN LOW"	Sensor output is below ADC min. value.	Defective sensor module or transmitter board ADC
FAULT4 "EROM ERR"	Defective Transmitter EEPROM Checksum	Defective Transmitter board EEPROM
FAULT5 "+24V LOW"	It occurs when 24 V main input power is inputted with voltage below 17V.	Input power below 17 V or defective Transmitter ADC
FAULT6 "ADC FAIL"	Defective Transmitter ADC	Defective Transmitter ADC
FAULT7 "H/W REV"	H/W Version Error	Defective MPU inside Transmitter
FAULT8 "SEN HUNT"	When there is repeated hunting error in gas measurement	Sensor output status may be poor or check for input power noise.

[Table 6. Fault List]

8.2. Recovery List

No	CAUSE	SOLUTION
1	Defective Sensor Module	Change Sensor
2	Defective Transmitter Board ADC	Change Transmitter Board
3	Defective Transmitter Board EEPROM	1) Perform Factory Initialization then correct parameter and re-calibrate 2) Change sensor unit when the same problem occurs again
4	Defective MPU inside Transmitter	Change Transmitter Main Board
5	Poor Sensor Output Status	Change Sensor
6	Check Input Power Noise	Check External Input Voltage Noise Status

[Table 7. Recovery List]

9.1. MODBUS RS485

9.1.1. Interface setting

- Data Format: RTU
- Baud rate: 9600 bps
- Data bits: 8bits
- Stop bit: 1bits
- Parity: Even
- For details, please go to www.modbus.org

9.1.2. MODBUS RS485 Register map

TYPE	ADDRESS	BITS	DESCRIPTION
Measured Gas Concentration	30001	BIT15~0	Gas Measurement (Integer/Decimal point is not considered)
High Scale Setting	30002	BIT15~0	High Scale Setting (Integer/Decimal point is not considered)
Alarm 1 Setting	30003	BIT15~0	Alarm 1 Setting (Integer/Decimal point is not considered)
Alarm 2 Setting	30004	BIT15~0	Alarm 2 Setting (Integer/Decimal point is not considered)
Gas detector status value	10000	BIT0	Alarm 1 Active Status
		BIT1	Alarm 2 Active Status
		BIT2	Fault Active Status
		BIT3	Maintenance Mode Status
		BIT4	Test Mode Status
		BIT5	Calibration Mode Status
		BIT6	Reserved
		BIT7	Toggle Bit (Bit reversal in 2 sec interval)
External Test	3	BIT0~7	Gas Detector Test Mode Setting
External Reset	2	BIT0~7	Exit Gas Detector Test Mode

[Table 8. RS485 Address Configuration]

10.1. Standard Type

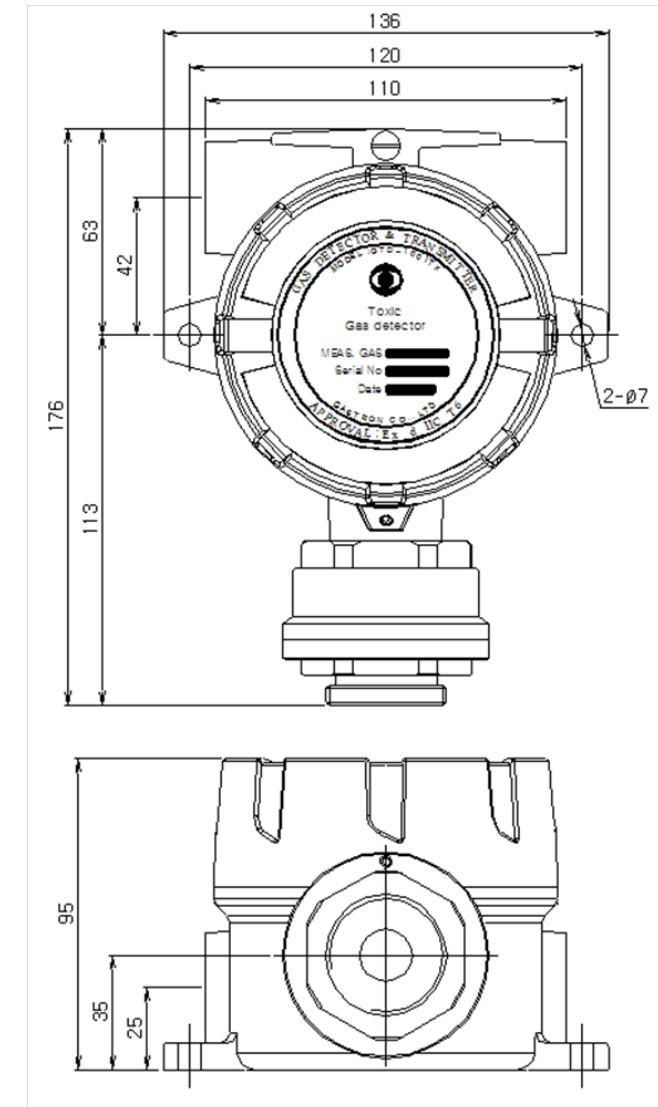

[Figure 11. GTD-1000Tx(M) Standard Type Drawing]

11.1. Selecting a Place for Installation (Occupational Health & Safety Act Data)

A gas leak detector alarm shall be installed in the following places.

- Around chemical equipment and accessories that have concerns of gas leak. This includes compressors, valves, reactors, pipe joints, etc. installed inside and outside of a building that handle combustible and toxic materials.
- Places that are easier for gases to stay such as areas around manufacturing facilities with ignition sources like heating furnace, etc,
- Areas around equipment for filling combustible and toxic materials.
- Substations, panel rooms, control rooms, and etc. located within explosive area.
- Other areas that are easier for gases to stay.

11.2. Selecting a Site for Installation (High-Pressure Gas Safety Control Act Data)

Gas detector of gas leak detector alarm must be installed as close to the areas with concerns of gas leakage as possible. However, for areas where direct gas leakage is not expected but are easier for leaked gas to stay, the detector must be installed at the point 1 of the following.

- Gas leak detector alarm installed outside a building shall be installed at points where gas is likely to stay in consideration to wind direction, wind speed, specific gravity of gas, etc.
- Gas leak detector alarm installed inside a building shall be installed near the floor when the specific gravity of gas is heavier than air and near ventilation of ceiling when it is lighter than air.
- Alarm for gas leak detector alarm must be installed at sites where the gas detector is installed and workers are present.

11.3. Precautions during Installation

Avoid areas with electrical barriers such as rain water, etc. It is recommended to be installed in areas that are easier to work in since regular maintenance is needed. Avoid areas with vibration or shock since they can affect output values. Sensor part must be installed towards the direction of gravity.

- This equipment has explosion-proof construction for internal pressure and belongs to GROUP II for gas and vapor in general work sites and chemical plants. It can be used in ZONE 1 (ONE) and ZONE 2 (TWO) hazardous sites.
- Allowable temperature is 85 C or below, which corresponds to T6.
- Surrounding temperature shall be in a range of -20 to 50 °C (for Main body. For sensor, refer to each sensor manual.)

- Installation Height: 1,000 M below sea level
- Relative Humidity: 5% ~ 99% (Non-condensing)
- Installation Site: Indoor and Outdoor
- Explosion Ignition Group for Target Gas or Vapor: Ex d IIC T6
- During wiring work, use explosion-proof cable gland at cable inlet or tightly seal cable conduit during metal cable wiring construction to prevent spread of flames in case of explosion or movement of gas, etc. through the cable conduit within 50 mm. All materials including materials used for sealing of unused inlets must have safety certificates!
- When connecting the equipment with cable, screw thread must be tightened 5 threads or more.
- Work in conditions satisfying other [Standards for Selection, Installation, and Maintenance, etc. of Explosion-proof Electric Machine and Equipment Wiring, etc. at Work Site]

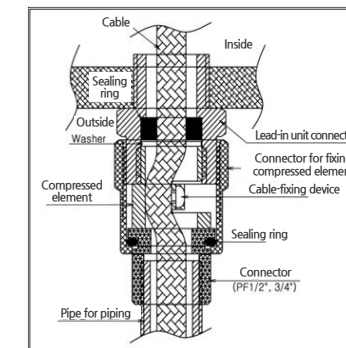

[Figure 12. High-Pressure Packing Type]

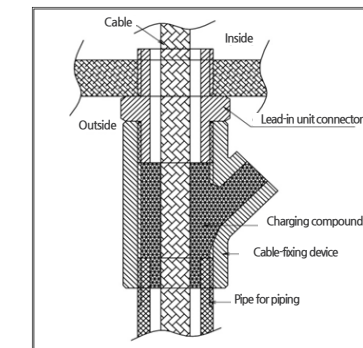

[Figure 13. Y Sealing Compound]

VERSION	CONTENTS	DATE
1.0	* Manual Initial Revision	2017.11.17
1.1	Changed Address	2018.01.04