



**Headquarters / Engineering research laboratory :**  
23 Gunpo Advanced Industry 1-ro(Bugok-dong), Gunpo-si, Gyeonggi-do  
Tel +82-31-490-0800 Fax +82-31-490-0801

**Yeongnam business office / Plant :**  
55 Gonghangap-gil, 85beon-gil, Gangseogu, Busan Metropolitan City  
Tel +51-973-8518 Fax +51-973-8519

E-mail : [info@gastron.com](mailto:info@gastron.com)

[www.gastron.com](http://www.gastron.com)

# GTF-1100T

## Instruction Manual



Read in detail for correct use.

# Gas & Flame Detection System

**GASTRON**



When abnormalities occur after purchasing the product,  
please contact the following address.

- Address : 23 Gunpo Advanced Industry 1-ro,  
Gunpo-si, Gyeonggi-do
- Tel : 031-490-0800
- Fax : 031-490-0801
- URL : [www.gastron.com](http://www.gastron.com)
- e-mail : [info@gastron.com](mailto:info@gastron.com)

## We sincerely thank you for purchasing the product of Gastron Co. Ltd.

Our Gastron Co.Ltd. is a company specialized in Gas detector and Gas Monitoring System, being recognized by many consumers due to the best quality and use convenience. We always enable you consumers to find desired products nearby and are ceaselessly studying and striving for development of Gas detectors satisfying customers. From now on, solve all anguishes concerning Gas detector with the products of Gastron Co. Ltd, We Gastron Co. will take a responsibility and give you satisfaction.

In the present instruction manual, operation method for Gas detector as well as simple methods for maintenance and repair, etc. are recorded. If you read it in detail and keep it well, for reference when you have questions, then it will give you much help.

- For accurate operation of Flame Detector, checkup for at least once in 6 months is recommended.
- When not checked up periodically, it may cause equipment malfunction due to problems resulting from sensor aging.
- When the present instrument should be dismantled, it must be conducted by the person with specialist skills for Flame Detector.
- For the contents concerning checkup of Flame Detector, please use the engineering department or e-mail, web site of our company.

The present product and the product manual can be changed without advance notice for performance improvement and use convenience of the product.

<b>1. Overview</b> .....	7		
<b>2. Features</b> .....	7		
<b>3. Product Order Number</b> .....	8		
<b>4. Specification</b> .....	9		
4.1. General Specifications .....	9		
4.2. Mechanical Specifications .....	9		
4.3. Electrical Specifications (Standard Type) .....	10		
4.4. Environmental Specifications .....	10		
4.5. Option Material .....	10		
<b>5. Detector Performance</b> .....	11		
5.1. Fuel and distance .....	11		
5.2. F.O.V. (Field of View) .....	11		
5.3. False Alarm Immunity .....	12		
5.4. Output Signal .....	13		
5.5. Detector Status .....	14		
5.6. Latching .....	15		
5.7. B.I.T. (Built In Self Test) .....	15		
5.8. Trouble Alarm .....	15		
5.9. 0~20mA Analog Current Output .....	16		
5.10. RS-485 Address setting .....	16		
<b>6. Installation</b> .....	17		
6.1. Separation of Body Cap .....	17		
6.2. Configuration of Terminal PCB .....	18		
6.3. Cable Wiring .....	19		
6.4. Length of installed Cable .....	20		
6.5. Wiring .....	21		
		6.5.1. Relay Wiring .....	21
		6.5.2. Configuration of Analog Output Cable .....	22
		6.5.3. Configuration of RS-485 Cable .....	23
		<b>7. Name and description of each part</b> .....	24
		7.1. Configuration of front face .....	24
		7.2. Components .....	25
		<b>8. Dimensions</b> .....	27
		8.1. GTF-1100T Dimensions .....	27
		8.2. GTF-1100T + Weather Proof Cover + Bracket Assembly Dimensions .....	28
		8.3. GTF-1100U name plate (KFI Korea Fire Institute) .....	29
		<b>9. Operating</b> .....	30
		9.1. Application of power supply .....	30
		9.2. Default Functions Settings .....	30
		9.3. Auto B.I.T .....	30
		9.4. Test using GFS-310 Simulator .....	31
		<b>10. Approvals</b> .....	31
		10.1. CE .....	31
		10.2. KCs .....	32
		<b>11. Accessories</b> .....	33
		11.1. Flame Simulator (Part No. GFS-310) .....	33
		11.1.1. Overview .....	33
		11.1.2. Features .....	33
		11.1.3. Operation .....	33
		11.1.4. Trouble display .....	34
		11.1.5. General Specifications .....	34

11.1.6. Mechanical Specifications .....	34
11.1.7. Electrical Specifications (Standard Type) .....	34
11.1.8. Environmental Specifications .....	35
11.1.9. Charger Specifications .....	35
11.1.10. Name of each part .....	36
11.1.11. Charging the Battery .....	37
11.1.12. EMC .....	37
11.2. Weather Proof Cover (Part No. FWP-1000) .....	38
11.3. Weather Proof Cover Assembly .....	39
11.4. Mounting Bracket Dimension (Part No. FMB-1000) .....	40
11.5. Bracket Assembly .....	41
11.6. Bracket Tilt .....	42
11.7. Cable Grand Direction .....	43
<b>12. Notes upon installation</b> .....	44
<b>13. Revision record</b> .....	45

GTF-1100T Flame Detector has been developed to prevent large-scale accidents beforehand by early detection of fire that can occur in all industry fields.

It can be installed in all industry fields where fire can occur, and is installed in the area with a risk of fire for constant, continuous detection.

By insertion of 3 types of high-sensitivity sensors capable of sensing infrared wavelength band that cannot be discerned with naked eyes upon fire, it was made for detect fire quickly with minimization of false alarms due to interference factors.

Situations are displayed by LED installed inside the product, and 0-20mA Analog Current Output, RS-485 communication Signal, Alarm Relay, Trouble Relay contact Signal are outputted.

## 2. Features

- Triple IR sensor
- Detection distance: 50m
- FOV (Field of View): Horizontal: 100°, Vertical: 100°
- Automatic and manual self-diagnosis function (B.I.T. Built In Self Test)
- Interface
  - Relay contact output (Fire and breakdown)
  - RS-485 communication
  - 0~20mA output
- Display lamp
  - Status LED (Bi-Color: RED and GREEN), Alarm LED (RED)
- Certification
  - EMC: EN50130-4, EN61000-6-4
  - KCs (Ex d IIC T6/T5/T4)
  - KFI: Gam17-86
- Accessory
  - Flame Simulator (Part No. GFS-320)
  - Weather Proof Cover (Part No. GWP-1000)
  - Mounting Bracket (Part No. FMB-1000)

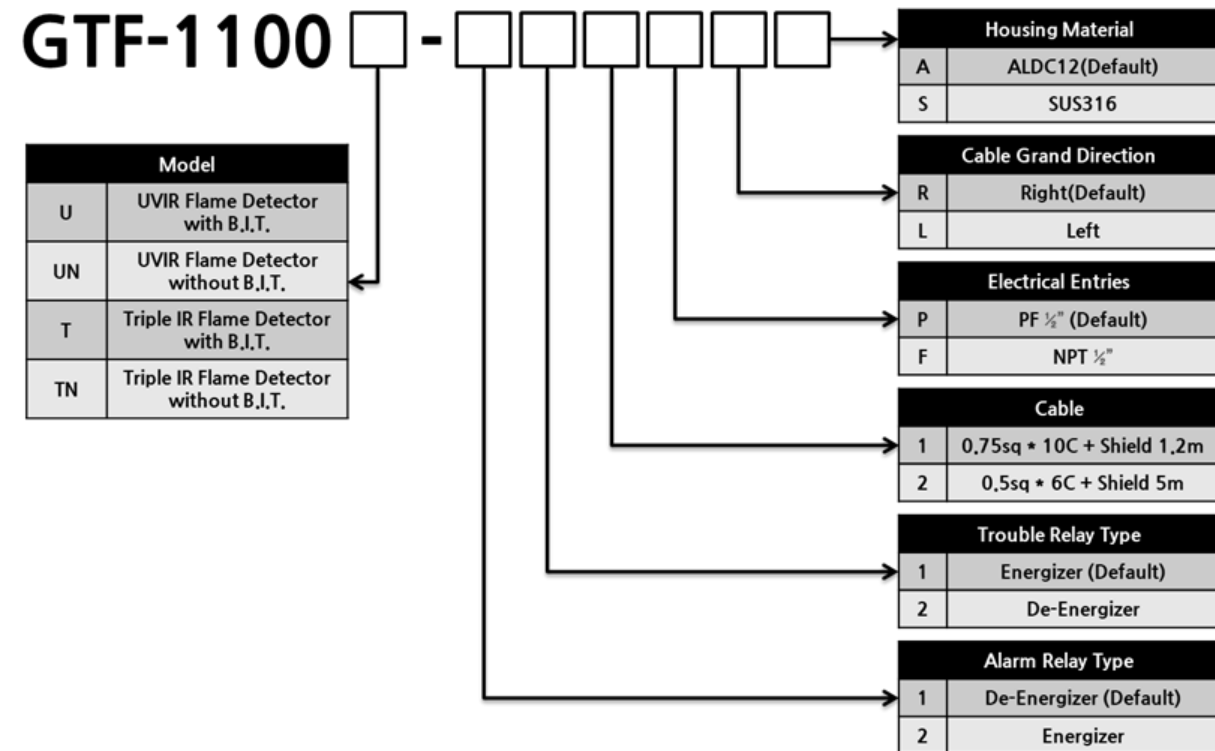

GTF-1100T-111PRA

- Model: GTF-1100T Triple with B.I.T.
- Alarm Relay Type: De-Energizer
- Trouble Relay Type: Energizer
- Cable: 0.75sq \* 10C + Shield 1.2m
- Electrical Entries: PF 1/2"
- Cable Grand Direction: Right (Based on front face of Detector. See Table 25)
- Housing Material: ALDC12

4.1. General Specifications

ITEMS	SPECIFICATION	
Wavelengths	Multi IR Channel	3.8 - 5.5µm
Detection Distance	50m (0.1 m2 n-Heptane pan fire)	
Field of View	Horizontal: 100°, Vertical: 100°	
Typical Response Time	Typical 5sec (0.1 m2 n-Heptane pan fire / 50m)	
Indicator	Status LED(Bi-Color: Red & Green) Alarm LED(Green)	
Output	0-20mA Analog Current Output 1 Alarm Relay, 1 Trouble Relay SPST (1A at 30VDC or 0.3A at 125VAC) RS-485 Interface (MODBUS RTU)	
Approvals Classification	KCs: Ex d II C T4, T5, T6	
Warranty	2 Years	

4.2. Mechanical Specifications

ITEMS	SPECIFICATION
Explosion Proof type	Explosion Proof enclosure
Dimension (GTF-1100T)	76(W) × 76(H) × 96.5(D) mm
Dimension (GTF-1100T + Assembly)	150(W) x 126(H) x 240(D) mm
Weight (Detector Only)	App. 0.7kg
Cable inlet	1/2" PF, PT, NPT(1/2" PF for Basic specifications)
Housing Material	ALDC12 or SUS316

### 4.3. Electrical Specifications (Standard Type)

ITEMS	SPECIFICATION	
Operating Power	Absolute min:	18V
	Nominal:	24V
	Absolute max:	32V
	Ripple maximum allowed:	1V pk-pk
Power consumption	Stand by (Without B.I.T.)	1.3W @32VDC
		1.2W @24VDC
		1.1W @18VDC
	Stand by (With B.I.T.)	2.4W @32VDC
		2.3W @24VDC
		2.2W @18VDC
Alarm	1.4W @32VDC	
1.3W @24VDC		
1.2W @18VDC		
Wiring Specifications	CVVSB with shield 0.75sq * 10C	
EMC Protection	EN50130-4, EN61000-6-4	

### 4.4. Environmental Specifications

ITEMS	SPECIFICATION
Ambient Temperature	T6 = -50°C ≤ Ta ≤ 60°C T5 = -50°C ≤ Ta ≤ 75°C T4 = -50°C ≤ Ta ≤ 85°C
Operation Temperature	-40°C ~ 75°C
Storage Temperature	-50°C ~ 80°C
Operation Humidity	5 to 99% RH (Non-condensing)

### 4.5. Option Material

ITEMS	SPECIFICATION
Flame Simulator GFS-320	ALDC12
Weather Proof Cover FWP-1000	ALDC12 or SUS316
Mounting Bracket FMB-1000	ALDC12 or SUS316

[Table 1: Specification]

### 5.1. Fuel and distance

FUEL	DISTANCE(m)
n-Heptane	50

[Table 2: Fuel and distance]

### 5.2. F.O.V. (Field of View)

■ Horizontal: 100°

■ Vertical: 100°

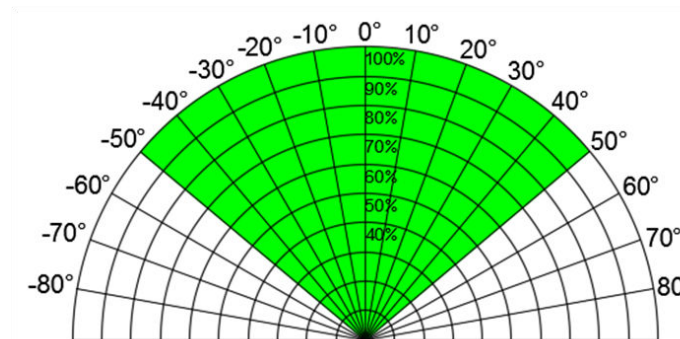

[Figure 1: Horizontal]

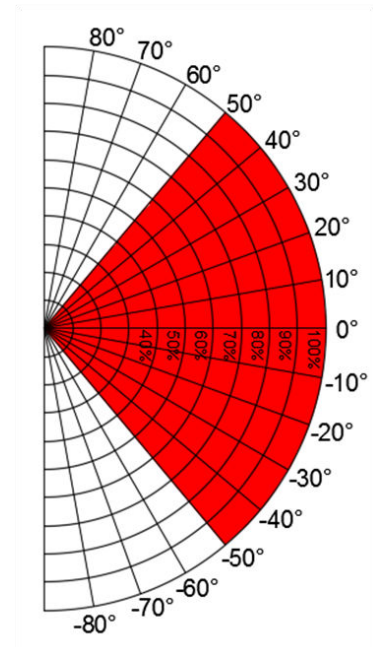

[Figure 2: Vertical]

### 5.3. False Alarm Immunity

■ As shown below, there are non-fire elements affecting flame detection, and the following table marks the conditions not recognized as fire by the Detector.

No	False Alarm Source	Modulated Response(m)	Unmodulated Response(m)
1	Fluorescent lamp 35W * 2	IAD	IAD
2	Halogen lamp 1kW	IAD	IAD
3	Indirect or reflected sunlight	IAD	IAD
4	Arc welding [(4 ± 1) mm 4313 (KS D 7004) / (190 ± 20) A]	1m	1m
5	Grinding metal	1m	1m
6	Radiation Heater 1.5kW with Fan	IAD	IAD
7	Radiation Heater 3kW	IAD	IAD
8	Incandescent frosted glass light 300W	IAD	IAD
9	Mercury vapor lamp 175W	IAD	IAD
10	Sodium lamp 70W	IAD	IAD
11	Lit cigarette	IAD	IAD
12	Lit cigar	IAD	IAD
13	Match, Wood, Stick including flare up	1m	1m
14	Flashlight(MX 991/U, Pelican Stealth Lite 2460)	IAD	IAD

[Table 3: False Alarm Source list]

■ IAD = Immune at Any Distance



### 5.4. Output Signal

- 2 Relay Out(Alarm, Trouble)
- 0~20mA Analog Current Output (stepped)
- RS-485 Modbus

OUTPUT TYPE	OUTPUT	NOTE
Alarm Relay (De-energized)	SPST Basic setting N.O	N.O or N.C can be changed by using J2 Jumper
Trouble Relay (Energized)	SPST Basic setting N.O	N.O or N.C can be changed by using J3 Jumper
0~20mA Analog Current Output	Source Type	
RS-485	Modbus RTU Protocol	

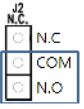

[Table 4: Output Signal]

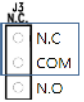
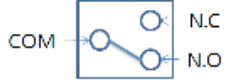
■ Alarm Relay (De-energized)

STATUS		
Normal Status		
Alarm Status		

[Table 5: Alarm Relay operation and Jumper change]

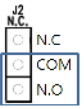
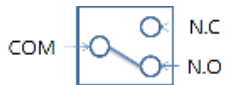
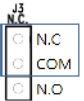
■ Trouble Relay (Energized)

STATUS		
Normal Status		
Trouble Status		

[Table 6: Trouble Relay operation and Jumper change]

### 5.5. Detector Status

■ By checking the following table, the current state of Detector can be confirmed.

STATUS	DESCRIPTION
Warm UP	Implement each function inspection after application of power supply
Normal	Standby state for fire measurement after completion of function inspection
B.I.T.	Self diagnosis function implemented at periodic times or manually to check normal operation of each sensor
Trouble 1 Voltage variation	Occurs when the input power supply breaks away from the operation range (18~32VDC) to be maintained for more than 5 sec, and the total occurrence frequency of disability is saved
Trouble 2 Self diagnosis error	Occurs when sensor reaction is less than the reference value upon operation of inside self-diagnosis lamp
Trouble 3 System error	Occurs when the inspection of data validity of inside EEPROM fails
Trouble 4 Sensor error	Occurs when detection inability state is maintained for more than 1 hour as the reference potential of IR sensor goes up or down
Pre Alarm	Detect fire risks
Fire Alarm	Detect fire

[Table 7: Detector Status]

■ Output of each function can be checked according to operation state of the Detector.

STATUS	POWER LED	STATUS LED	ALARM RELAY	TROUBLE RELAY	MA OUTPUT
Warm UP	Green, Red Cross blinks for 500ms	Red Blinks for 500ms	OFF	OFF	0mA±3%
Normal	Green blinks once for 3s	OFF	OFF	ON	4mA±3%
B.I.T.	Green blinks once for 3s	OFF	OFF	ON	4mA±3%
Trouble 1 Voltage variation	Yellow blinks once for 1s	OFF	OFF	OFF	0mA±3%
Trouble 2 Self diagnosis error	Yellow blinks once for 1s	OFF	OFF	OFF	1mA±3%
Trouble 3 System error	Yellow blinks 3 times for 1s	OFF	OFF	OFF	1.5mA±3%
Trouble 4 Sensor error	Yellow blinks 4 times for 1s	OFF	OFF	OFF	2mA±3%
Pre Alarm	Green blinks once for 3s	Red blinks for 200ms	OFF	OFF	4mA±3%
Fire Alarm	Green blinks once for 3s	Red lighted	ON	OFF	20mA±3%

[Table 8: Detector Status Output]

### 5.6. Latching

- Detection state is maintained upon fire detection.
- All Outputs are maintained to be same as fire while Latching state is maintained
- B.I.T. cannot be used while Latching state is maintained
- Normal state can be returned to when the power supply is turned ON again after being turned OFF
- Set for Latch On as basic setting.

### 5.7. B.I.T. (Built In Self Test)

- Check the status of automatic operation of each sensor
- Automatic operation once in 1 hour after Warn UP
- Manual operation is possible by using B.I.T terminal of Terminal PCB. It operates when B.I.T. terminal is connected to N24.
- When errors occur upon implementation of automatic B.I.T, determine abnormality status by re-execution for 10 times by the unit of 5sec.
- Self diagnosis error of Trouble2 occurs when operation of Sensor or Source is not normal or abnormality occurred in PCB.

### 5.8. Trouble Alarm

- Trouble can be checked by a total of 4 types of output
- Power LED blinks in Yellow, and fire detection is not possible until actions are taken.
- Trouble can be checked by Trouble Relay, 0~20mA, RS-485

TROUBLE	CONTENT	RETURN CONDITION
Trouble 1 Voltage variation	Occurs when the input power supply breaks away from the operation range (18~32VDC) to be maintained for more than 5 sec, and the total occurrence frequency of disability is saved	Normal state is automatically returned to when voltage returns to the normal range
Trouble 2 Self diagnosis error	Occurs when sensor reaction is less than the reference value upon operation of inside self-diagnosis lamp	Detector checkup required
Trouble 3 System error	Occurs when the inspection of data validity of inside EEPROM fail	Detector checkup required
Trouble 4 Sensor error	Occurs when detection inability state is maintained for more than 1 hour as the reference potential of IR sensor goes up or down	Detector checkup required

[Table 9: Trouble Alarm]



5.9. 0~20mA Analog Current Output

- Analog Current Output as a function of Detector state.
- Checking is possible by using mA terminal. Of Terminal PCB

STATE	OUTPUT
Warm Up	0mA±3%
Power Trouble	0mA±3%
B.I.T Trouble	1mA±3%
System Trouble	1.5mA±3%
Sensor Trouble	2 mA±3%
Normal	4mA±3%
Fire Alarm	20mA±3%

[Table 10: Analog Current Output]

5.10. Setting for RS-485 Address

- RS-485 Address can be changed by using Dip Switch in .
- Up to the maximum of No. 31 can be set by using Nos.1~5 Switches.
- Normal Data reception is not possible when Addresses are overlapped.
- It is turned ON when the switch is set upward, while it is turned OFF when the switch is set downward.

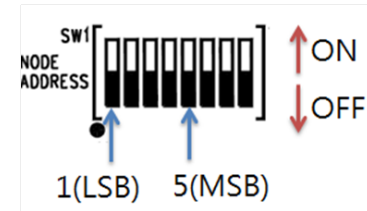

Switch No. Address	1 (LSB)	2	3	4	5 (MSB)
1 (0x01)	ON	OFF	OFF	OFF	OFF
2 (0x02)	OFF	ON	OFF	OFF	OFF
3 (0x03)	ON	ON	OFF	OFF	OFF
4 (0x04)	ON	OFF	ON	OFF	OFF
5 (0x05)	OFF	ON	ON	OFF	OFF
...	...	...	...	...	...
28 (0x1C)	OFF	OFF	ON	ON	ON
29 (0x1D)	ON	OFF	ON	ON	ON
30 (0x1E)	OFF	ON	ON	ON	ON
31 (0x1F)	ON	ON	ON	ON	ON

[Table 11: RS-485 Address]

- Others than approved users or personnel of the headquarters in charge of installation and repair should never be allowed to install in the field , open or operate the cover of the installed Flame Detector. Otherwise, serious damages to life and property such as fire or explosion accidents van be inflicted. Also, make sure shut off power supply for operation after checking whether explosive gas remains or there are flammable substances in the surroundings.

6.1. Separation of Body Cap

- Separate M3 headless bolt fastened to Body Cap by using a range.
- Separate the Body Cap by turning it counterclockwise. When the Body Cap is separated, terminal box.

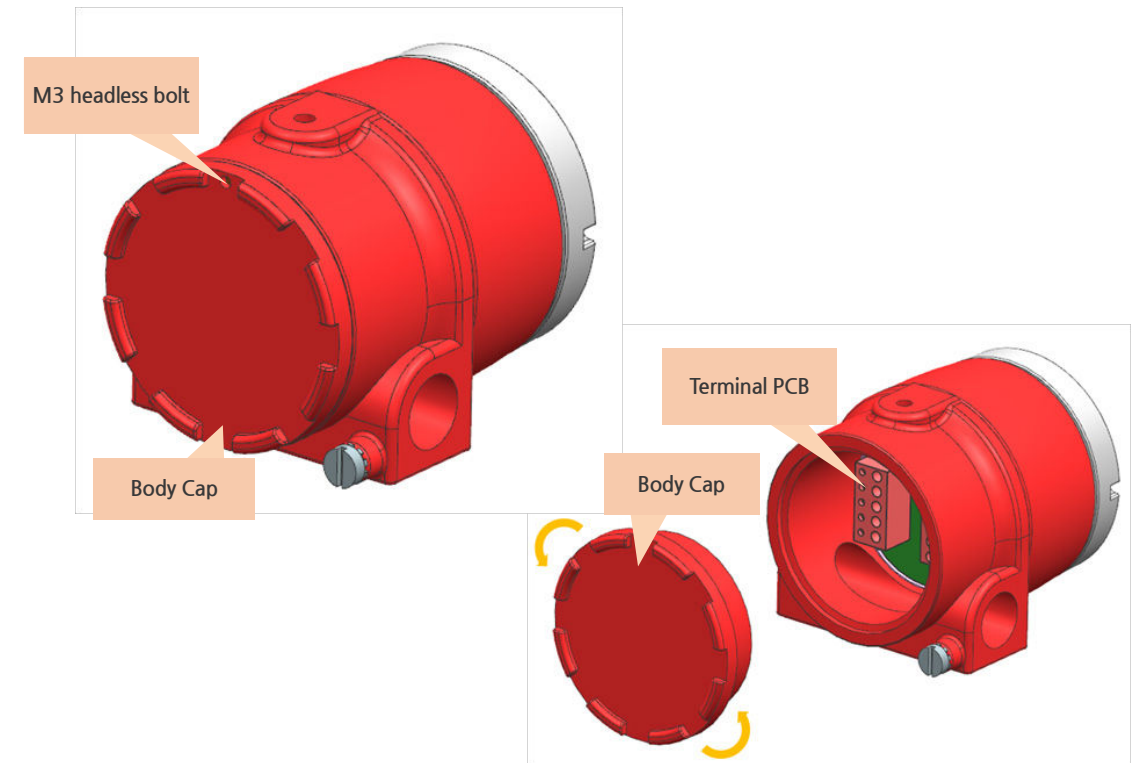

[Figure 3: Separation of Body Cap]

6.2. Configuration of Terminal PCB

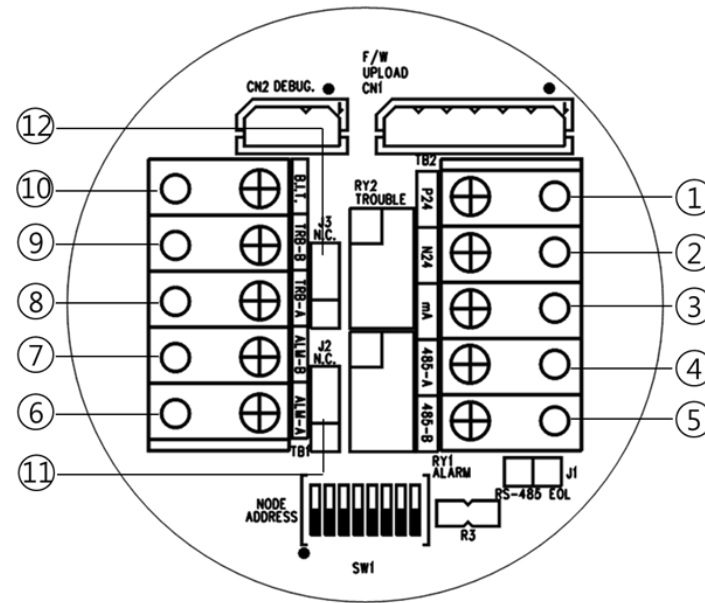

[Figure 4: Layout for Terminal PCB terminals]

■ Configure power supply and signals by using TB1, TB2 terminals of Terminal PCB.

NO.	TERMINAL NAME	DESCRIPTION
1	P24	Positive Input
2	N24	Negative Input
3	mA	0-20mA Analog Current Output
4	485-A	RS-485 Positive Signal
5	485-B	RS-485 Negative Signal
6	ALM-A	Alarm Relay Contact Output
7	ALM-B	
8	TRB-A	Trouble Relay Contact Output
9	TRB-B	
10	B.I.T.	Manual Built in Self Test Input (Dry-Contact)

[Table 12: Configuration of terminal box]

6.3. Cable Wiring

- Use 0.75sq \* 10C + Shield Cable .
- To perfectly comply with EMC guidelines and protect from interference due to RFI and EMI, Cable for Detector should be shielded and the Detector grounded. Shield should be grounded at the tip of Detector.

NO.	CONNECTOR NO.	COLOR
1	P24	Red
2	N24	Black
3	mA	White
4	485-A	Yellow
5	485-B	Orange
6	ALM-A	Purple
7	ALM-B	Brown
8	TRB-A	Green
9	TRB-B	Blue
10	B.I.T.	Gray
11	Shield	Shrinkage tube in Black

[Table 13: Cable Wiring]

6.4. Installation Length of Cable

- Maximum length between GTF-1100T and power supply device is determined by the wire specifications.
- Maximum installation length=  $V_{MAXDROP} \div I_{MAX} \div WIRER/m \div 2$ 
  - VMAX Drop: Maximum Power Loop Voltage Drop  
(=Power Supply voltage - min operating voltage)
  - I MAX: Maximum current value for GTF-1100U
  - WIRER/m: The resistance of the wire (ohms/meter value available in wire manufacturer's ... specification data sheet)
- An example for installation length using 16AWG for the power supply device is as follows.
  - GTF-1100T minimum operating voltage = 18 V dc
  - VMAXDROP = 24 - 18 = 6V
  - IMAX = 0.122A
  - $6 \div 0.122 \div 0.01318 \div 2 = 1865.718m \approx 1866m$

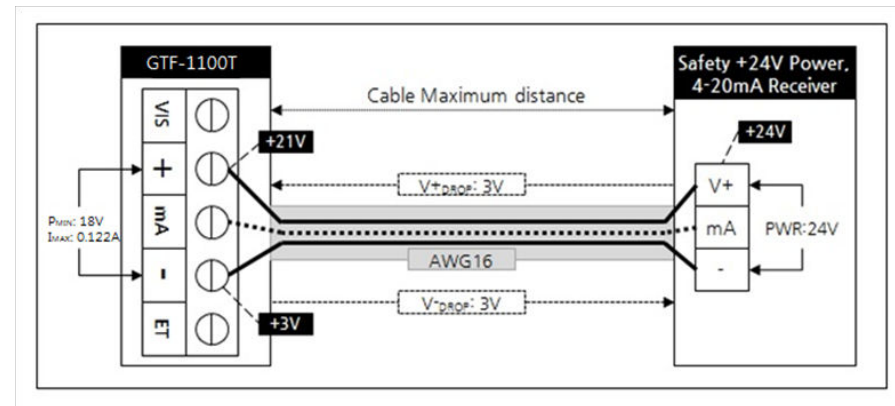

[Figure 5: Calculation of installation length of cable for GTF-1100T]

AWG	mm2	Copper resistance(ohms/m)	Meters
12	3.31	0.00521	4720
14	2.08	0.00828	2970
16	1.31	0.01318	1865
18	0.82	0.02095	1174
20	0.518	0.0333	739

[Table 14: Length according to classification of GTF-1100T Cable]

6.5. Wiring

- Wiring method for connection between Connector of Terminal PCB and outside equipment.

6.5.1. Relay Wiring

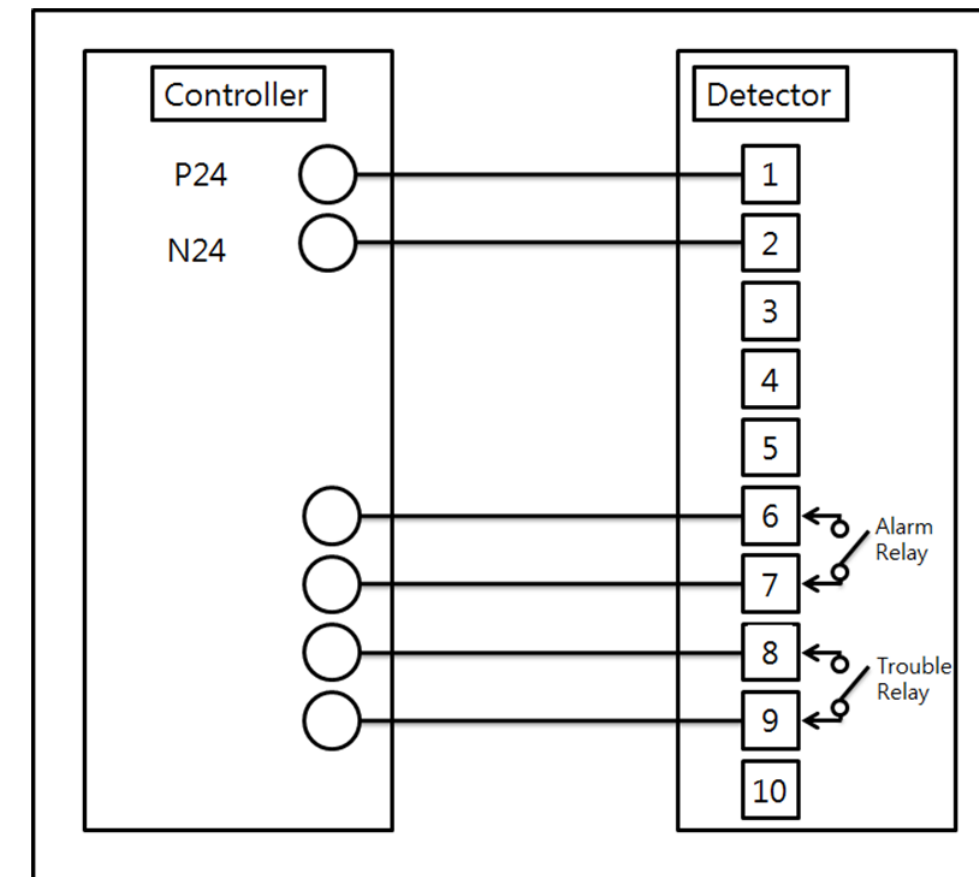

[Figure 6: Configuration of Relay Cable]

6.5.2. Analog Output Cable 구성

- 0~20mA Analog Output can be configured as Sink Type.

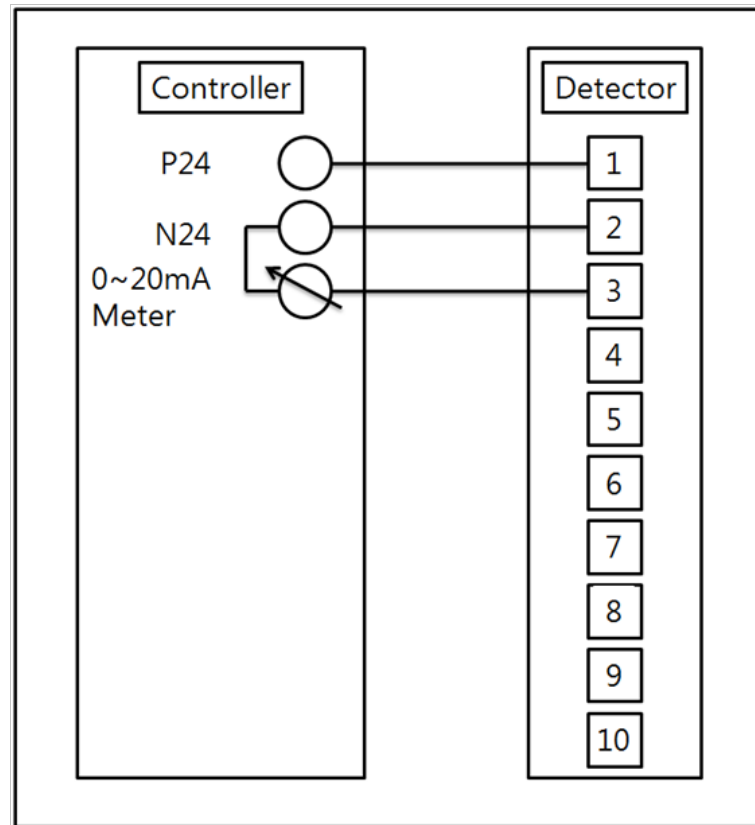

[Figure 7: Configuration of Analog Output Cable]

6.5.3. Configuration of RS-485 Cable

- Multiple configuration is possible in the case of RS-485
- By setting for RS-485 Address of Detector without overlapping, the maximum of 31 units can be connected.

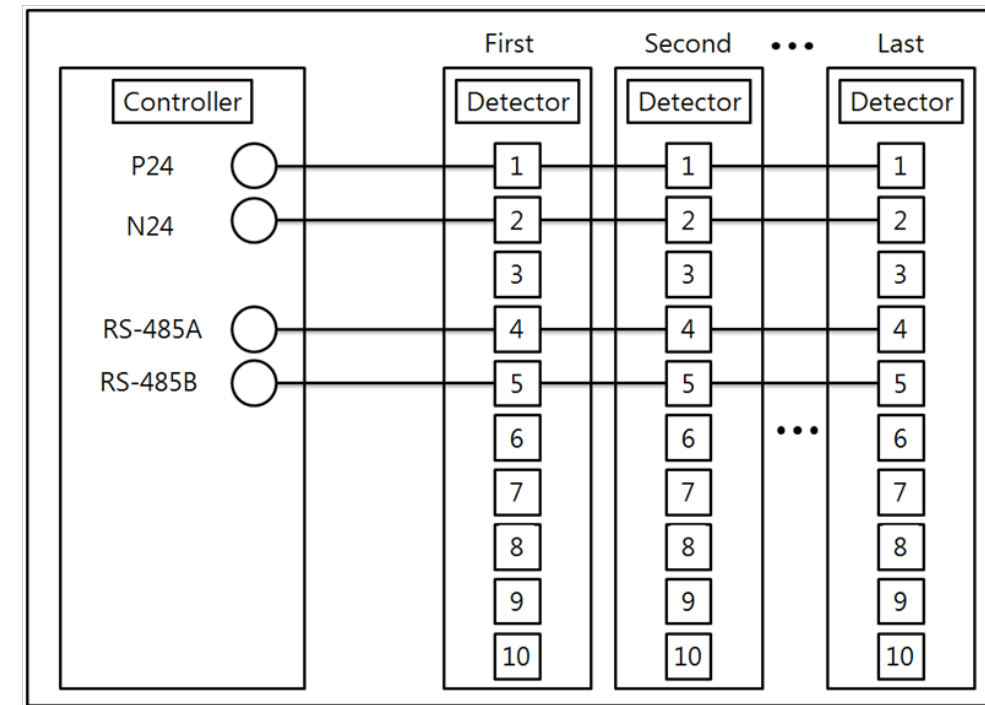

[Figure 8: Configuration of RS-485 Cable]

7.1. Configuration of front face

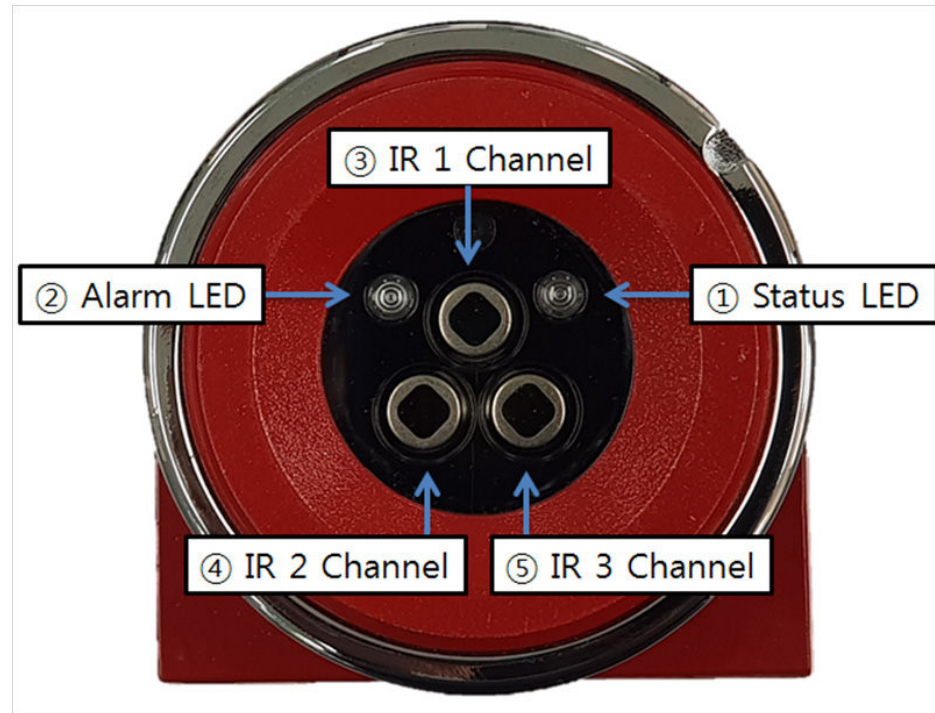

[Figure 9: Configuration of front face]

NO	NAME	DESCRIPTIONS
1	Status LED	Green blinks upon being normal Yellow blinks upon Trouble
2	Alarm LED	Lighted upon fire
3	IR 1 Channel	Sensor detecting the wavelengths in 4.5~4.8 μm band
4	IR 2 Channel	Sensor detecting the wavelengths other than CO2 band
5	IR 3 Channel	Sensor detecting the wavelengths other than CO2 band

[Table 15: Configuration of front face]

7.2. Components

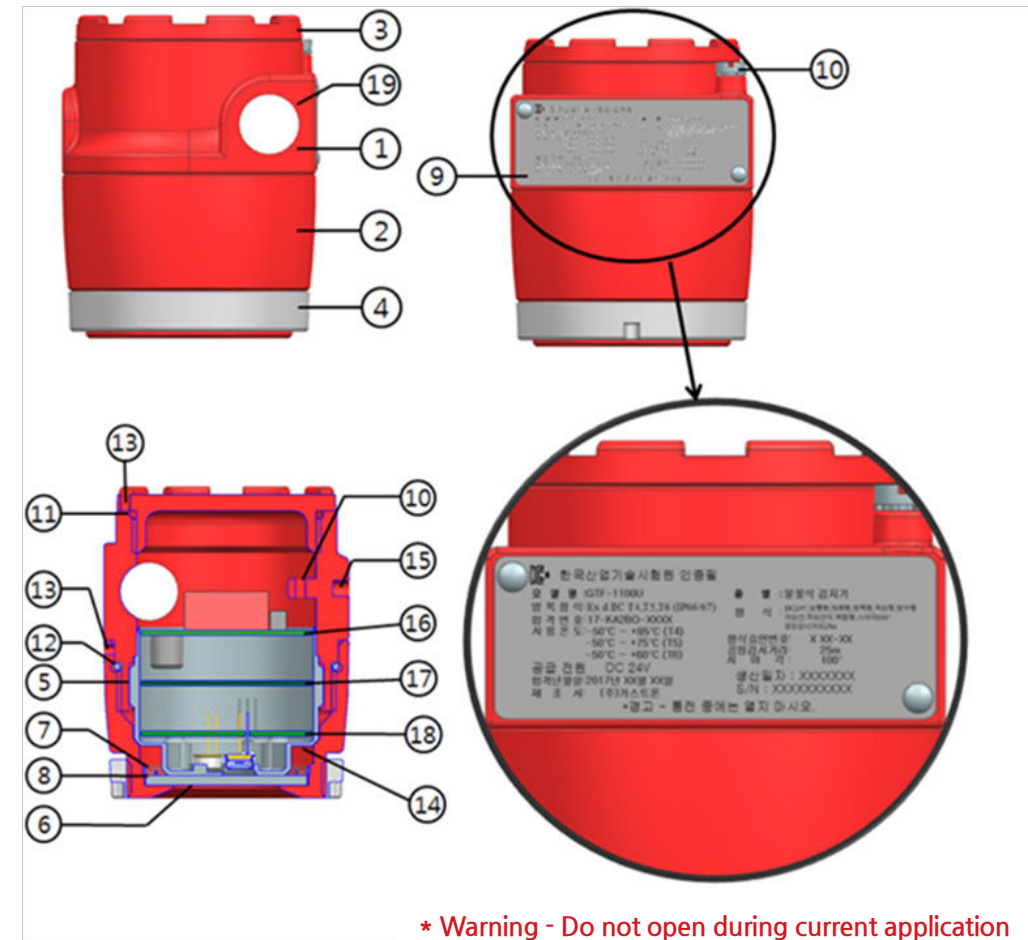

\* Warning - Do not open during current application

[Figure 10: Components of GTF-1100T]

NO.	TERMINAL NAME	DESCRIPTION
1	Case body	Protect PCB Board embedded inside Sensor and Housing from outside environment change and impact
2	Case cover	Assembled to Detector Housing Body. Protect PCB Board embedded inside from outside environment change and impact
3	Body cap	Protect PCB Board embedded inside Housing from outside environment change and impact
4	Cover ring	Ring that allows fixing of cover to bracket so as to facilitate fastening of front-face unit or mounting of Weather Proof Cover.
5	PCB cover	Protect Sensor and PCB Board from outside environment and impact upon assembly, making attachment/detachment convenient
6	Glass Sapphire	Permeation unit that protects Sensor embedded inside Housing from outside environment change and impact
7	Glass ring	Fixing ring that fixes Glass
8	Gasket	Prevent damages to glass, and play waterproofing role for blocking infiltration of rain water
9	Cert. label	Display model name, certification specifications, serial number, warning statement, etc. of the product (Warning - Do not open during current application.)
10	Internal / External Ground	To protect from outside Noise or strong electric field, inside/outside of the Detector should be grounded. (Grounding terminal: JOT4-6, Grounding Cable $\geq 4\text{mm}^2$ )
11	O-RING(AN138)	Play waterproofing role to prevent infiltration of rain water to inside
12	O-RING(S56)	Play waterproofing role to prevent infiltration of rain water to inside
13	SETHSC-M3-3-S4	Set screw that prevents opening of Cover in Detector housing body
14	SCRH-M3-6-NiP	Set screw that separates PCB and PCB protection cover
15	Mount Bracket tap	Bracket installation tap to fix the Detector on outer wall or other mount hole.
16	TERMINAL PCB	Composed of Connector allowing connection with outside equipment and Dip Switch for setting of RS485 Address.
17	MAIN PCB	Composed of Detect fire and control each output signal by computing signals from the sensor.
18	SENSOR PCB	Composed of Status LED and Alarm LED that allow checking states of sensor for fire detection, source for self diagnosis, and detector
19	Electrical Connection	Connector to couple Cable Grand (PT 1/2")

[Table 16: Description of components]

8.1. GTF-1100T Dimensions

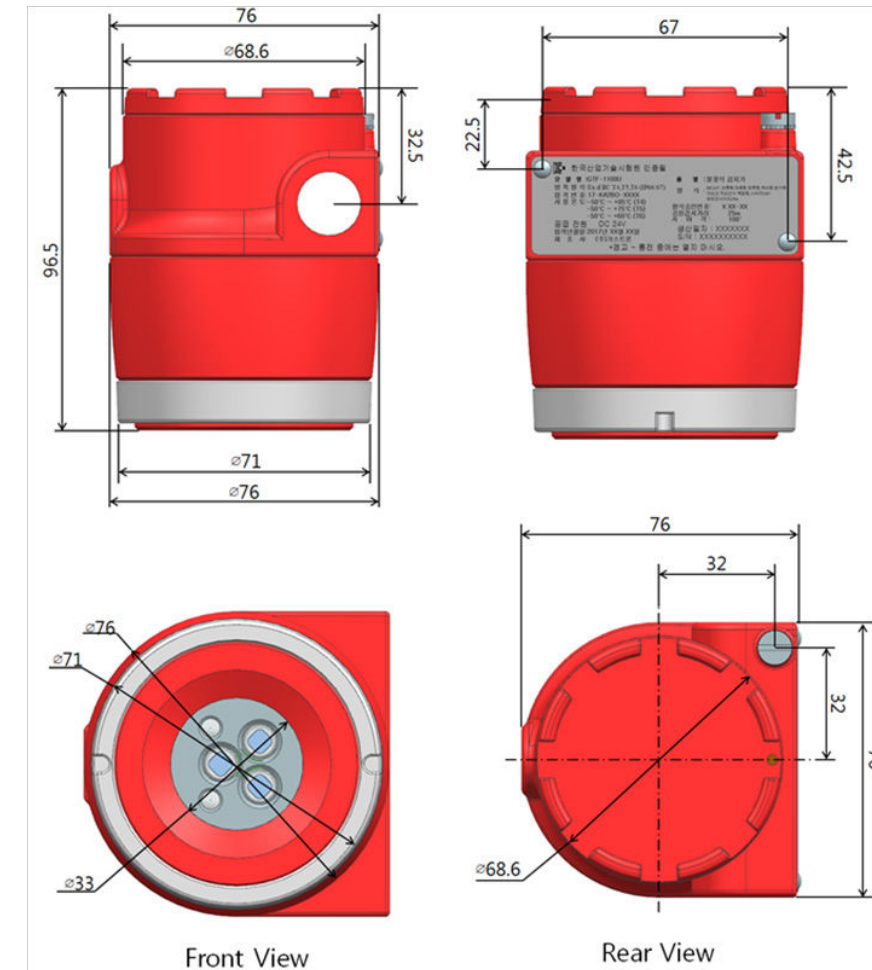

[Figure 11: GTF-1100T Dimensions]

8.2. GTF-1100T + Weather Proof Cover + Bracket Assembly Dimensions

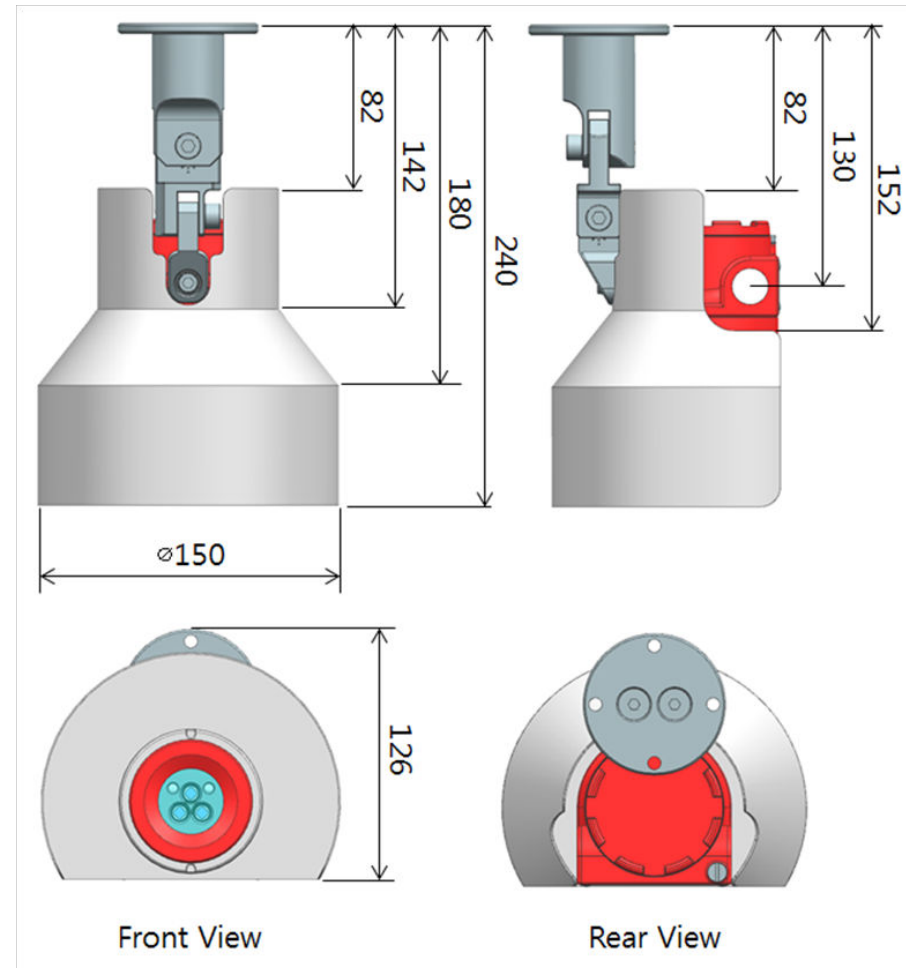

[Figure 12: GTF-1100T + Weather Proof Cover + Bracket Assembly Dimensions]

8.3. GTF-1100T nameplate(KFI, Korea Fire Institute)

<b>종 별</b> : 불꽃식 감지기 <b>형 식</b> : DC24V, 보통형, 재용형, 방수형, 방폭형, 국내 국외형, 적외선식, 시야각 100°, 유효감지거리 50m.(모델명 : GTF-1100T)		 한국산업기술시험원 인증필								
<b>형식승인번호</b> : 감18-19 아크용접 이격거리: 1m 이상 <b>유효감지거리</b> : 50m <b>시야각</b> : 100° <b>제조번호</b> : <b>제조일자</b> : <b>극성표시(단자)</b>										
P24	N24	mA	485-A	485-B	B.I.T.	TRB-B	TRB-A	ALM-B	ALM-A	<b>형 식 모 델</b> : GTF-1100T <b>인 증 번 호</b> : 17-KA2BO-0610 <b>발행년월일</b> : 2017년 10월 30일 <b>용 량 등 급</b> : Ex d IIC T6,T5,T4 (IP67) <b>제 조 사</b> : (주)가스트론 (Tel : 031-490-0800) <b>홈 페이지</b> : www.gastron.com
적	흑	백	황	주	회	청	녹	갈	자	<b>취급주의사항</b> 1) 사용설명서 필히 참조 할 것. 2) 감지기 분리 및 결합시 무리한 힘을 가하지 말 것. 3) 전원은 정전압을 사용해야 하므로 수신기에 회로전압과 램프용 전압 등을 사용할 수 없음. 따라서, 수신기에서 경유기를 거친 24V 전원에 연결하여 사용하여야 한다.
					4) 4-20mA, RS485통신, R형 수신반을 사용하는 경우, 팔히 대리점이나 제조사로 문의 바랍니다. 5) 본 제품은 극성표시된 단자별로 연결하여 사용하며 주시기 바랍니다. 6) 경고-통전 중에는 열지 마시오. 7) 관리담당자 및 (주)가스트론의 담당자 이외 조작금지!					

[Figure 13: Nameplate of GTF-1100T ]

- Please apply power supply after checking wiring state for normal operation of Detector or prevention of damages.

### 9.1. Application of power supply

- Apply power supply after checking the wiring state.
- When power supply is applied, Status LED and Alarm LED cross blink, starting Warm UP.
- While the Warm Up is in progress, execute inside System Check and B.I.T for operation checking.
- When inspection is completed, Status LED blinks in green, waiting in Normal state.
- When abnormal operation occurs during Warm Up ,Trouble Alarm occurs after completion of Warm Up.

### 9.2. Default Functions Settings

- Basic setting values set in Detector.

FUNCTION	SETTING VALUE	NOTE
Auto B.I.T	ON	
Latch	ON	
RS-485 Address	1	Can be changed according to field situations
Alarm Relay (De-Energized)	N.O	Can be changed according to requests or consumers
Trouble Relay (Energized)	N.O	Can be changed according to requests or consumers

[Table 17: Default Functions Settings]

### 9.3. Auto B.I.T

- Self diagnosis is implemented according to periodic times after Warm Up
- There is no change in Detector upon implementation of self diagnosis.
- Standby for fire detection is implemented in Normal state after normal completion
- Self diagnosis is re-executed by the unit of 5sec upon occurrence of self-diagnosis problems
- Trouble 2 occur upon occurrence of problems for more than 10 times in total. Requiring additional actions.
- Self diagnosis is not implemented when fire occurred with the Latch ON.
- Manual implementation of self diagnosis is possible by using B.I.T terminal of Terminal PCB

### 9.4. Test using GFS-320 Simulator

- Implement substitute tests for actual fire using Simulator as implementation of Test using actual fire in explosion-proof area or danger area is not allowed
- Detect fire by using the source producing a similar spectrum similar to fire in the installed Detector.
- Implement in the state of short-circuiting of wire connection with alarm or various fire-extinguishing system and outside devices since each function of Detector is outputted in the same way as fire upon implementation of Simulator Test
- See Accessories Page.

### 10.1. CE

- Test Standard(method) Used: EN 50130-4:2011, EN61000-6-4:2007 + A1:2011
- Emission Test Regulation / Standards

APPLIED STANDARD	TITLE
EN 61000-6-4:2007 + A1:2011	Radiated Electric Filed Emissions

[Table 18: Emission Test Regulation / Standards]

- Immunity Test Regulations / Standards

APPLIED STANDARD	TITLE
EN 50130-4:2011	
EN 61000-4-2:2009	Electrostatic Discharge
EN 61000-4-3:2006 + A1:2008 + A2:2010	Radiated Electric Filed Emissions
EN 61000-4-4:2012	Electrical Fast Transients / Bursts
EN 61000-4-5:2014	Surge Transients
EN 61000-4-6:2014	Conducted Disturbance

[Table 19: Immunity Test Regulations / Standards]



## 10.2. KCs

- Approvals Classification
  - KCs (Ex d IIC T6/T5/T4)
- Explosion Proof type
  - Explosion Proof Enclosure
- Ambient Temperature
  - T6 = -50 to 60°C
  - T5 = -50 to 75°C
  - T4 = -50 to 85°C
- Storage Temperature
  - -50 to 80°C
- Operation Temperature
  - -40 to 75°C
- Operation Humidity
  - 5 to 99% RH (Nn-condensing)
- Operating Voltage
  - 24V DC Normal (18~32V DC) / 106mA Max (32V with B.I.T).
- Enclosure Material : ALDC12 or SUS316
- Electrical Connection : PF 1/2"(Default), PT 1/2", NPT 1/2"
- Weight
  - Aluminum : 0.7kg
  - Stainless Steel : 2.1kg
- Dimension
  - 76mm(W) x 76mm(H) x 96.5mm(D)

## 11.1. Flame Simulator (Part No. GFS-320)

### 11.1.1. Overview

GTF-320 is a Test Simulator to check normal operation status of the Detector in explosion-proof or danger area with installation of GTF-1100T. It has been produced to conduct virtual fire test since tests using actual fire are not allowed. It has been produced in such a way that GTF-1100T can be recognized as fire by using arbitrary flicker as the source used for GFS-320 to produce IR and generating a spectrum similar to fire. It is made as a case of ALDC12 material in pressure-resistant, explosion-proof structure, allowing portability due to the light weight. When completely charged by using the dedicated charger, it can be used for about 100 times. Low-power design enables long-time carrying

### 11.1.2. Features

- Dedicated Simulator to test GTF-1100T
- Carrying possible due to configuration of the power supply as battery
- Use for about 100 times possible upon complete charging
- Long-term carrying possible due to low-power design
- Use in explosion-proof area or danger area possible due to design as a pressure-resistant, explosion-proof structure.

### 11.1.3. Operation

- Position GFS-320 so as to face front face of the Detector.
- When the operation Switch is pushed in the handle, function tests such as inside temperature Check, Battery Check, etc. are started.
- When function tests are normally completed, LED included in the operation switch is lighted in Green, and the source installed inside operates unperiodically for 30 sec.
- When Trouble occurs during function tests, it is expressed by color of the LED in the operation switch.
- Maintain until the Detector recognizes it as fire .
- When the operation Switch is pushed again or 30 sec passes during operation, it is automatically changed to standby state.
- When the Detector fails to recognize it as fire, confirm by repeating for 2~3 times.
- When the Detector fails to recognize it as fire despite the repeated operation, the Detector needs to checked up..
  - Check up foreign objects on Sapphire Glass of front-face unit of the Detector
  - Check up the Sensor through B.I.T

### 11.1.4. Display of Trouble

■ LED is lighted according to each Trouble, and turned OFF 3 sec later.

TROUBLE	LED COLOR
Low-voltage state for Battery	Red ON
Inside temperature rise	Red blinks for 500ms

[Table 20: Display of Trouble]

### 11.1.5. General Specifications

ITEMS	SPECIFICATION
Detection Distance	5m
Indicator	Status LED (2 Color)
Approvals Classification	KCs: Ex d II B T4, T5, T6
Warranty	2Year

### 11.1.6. Mechanical Specifications

ITEMS	SPECIFICATION
Explosion Proof type	Explosion Proof enclosure
Dimension	148(W) ×164(H) ×303(D) mm
Weight including Sensor	App. 0.7kg
Material	ALDC12

### 11.1.7. Electrical Specifications (Standard Type)

ITEMS	SPECIFICATION
Battery	14.8V (3.7V 4cell Ni-Ion Battery)
Current	2.8A
EMC Protection	EN 61000-6-3

### 11.1.8. Environmental Specifications

ITEMS	SPECIFICATION
Storage Temperature	-20℃ ~ 60℃
Operation Temperature	-20℃ ~ 50℃
Operation Humidity	5 to 99% RH (Non-condensing)

### 11.1.9. Charger Specifications

ITEMS	SPECIFICATION
Charger Input	AC 100~240V / 50~60Hz / 1.0A
Charger Output	16.8V / 2.5A
Charger Indicator	Bi-Color LED Indicator (RED & GREEN)
Fully Charge Time	App. 2 Hours

[Table 21: GFS-320 Specification]

11.1.10. Name of each part

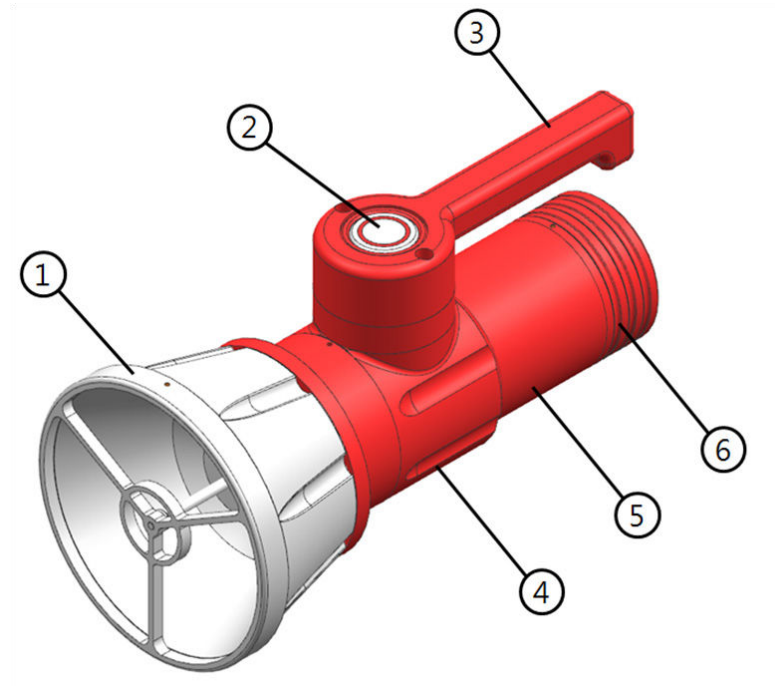

[Figure 14: Name of each part for GFS-320]

NO	NAME	DESCRIPTIONS
1	Reflector Assembly	Reflection plate to make emitted light of the Lamp to irradiate far away
2	Push Button	Turn on-off power supply of GFS-320 and inform the state by lighting of LED
3	Handle	Handle designed to facilitate grip of GFS-320.
4	Top Cover	Part protecting Main Board by being coupled with Body.
5	Body	Part protecting Main Board and Battery pack
6	Back Cover	Rear cover part protecting charging Jack connected to Battery Pack.

[Table 22: Description of each part for GFS-320]

11.1.11. Charging the Battery

- Places to avoid upon charging
  - Explosion-proof or danger area
  - Inside a car at high temperature (higher than 40°C)
  - Humid or wet place
- Separate Back Cover of Simulator.
- Connect Charger to DC Jack of Simulator.
- In the case of Charger, use the Charger supplied together with GFS-320.
- Display for progress state can be checked by LED of Charger.
  - Red lighted: In the process of charging
  - Green lighted: Charging completed
  - Red blinking: Trouble(Battery defect, Charger defect) occurred during charging.
- Operation does not occur even when the operation Switch is pushed during charging.
- When charging is completed, separate Charger from the Simulator for storage.

11.1.12. EMC

APPLIED STANDARD	TITLE
EN 61000-6-3	Radiated Emission

[Table 23: Emission Test Regulation / Standards]

APPLIED STANDARD	TITLE
EN 61000-4-2:2009	Electrostatic Discharge
EN 61000-4-3:2006 + A1:2008 + A2:2010	Radiated Electric Filed Emissions
EN 61000-4-6:2014	Conducted Disturbance

[Table 24: Immunity Test Regulations / Standards]

11.2. Weather Proof Cover (Part No. FWP-1000)

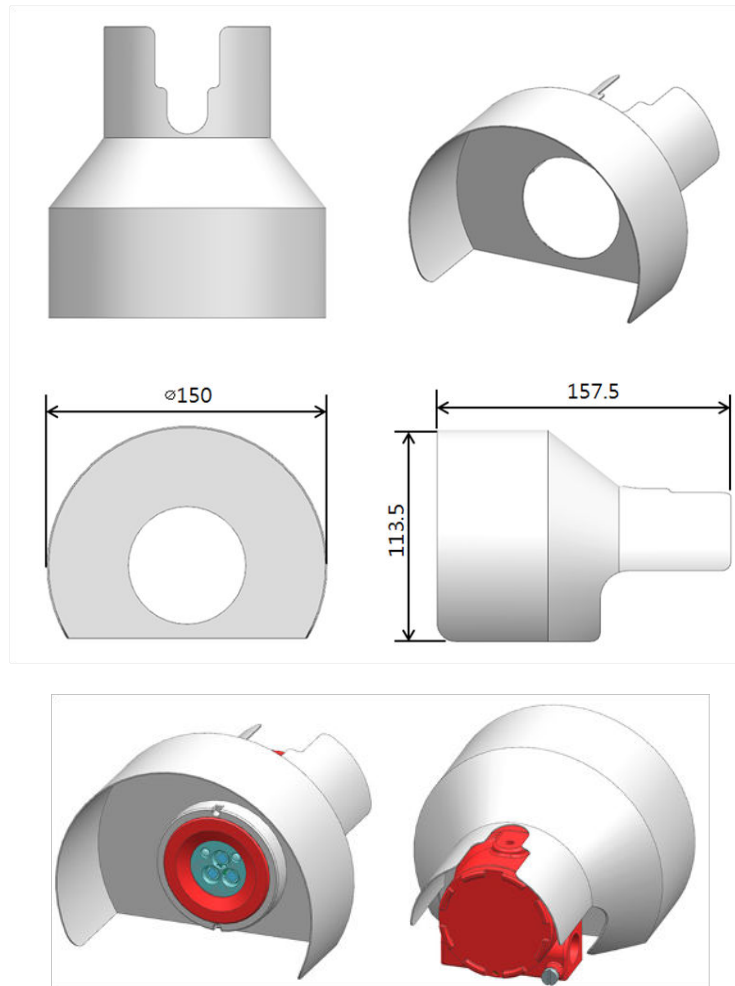

[Figure 15: Weather Proof Cover]

11.3. Weather Proof Cover Assembly

1. Disassemble the Cover Ring from GTF-1100T by turning it in the direction as shown in the figure.

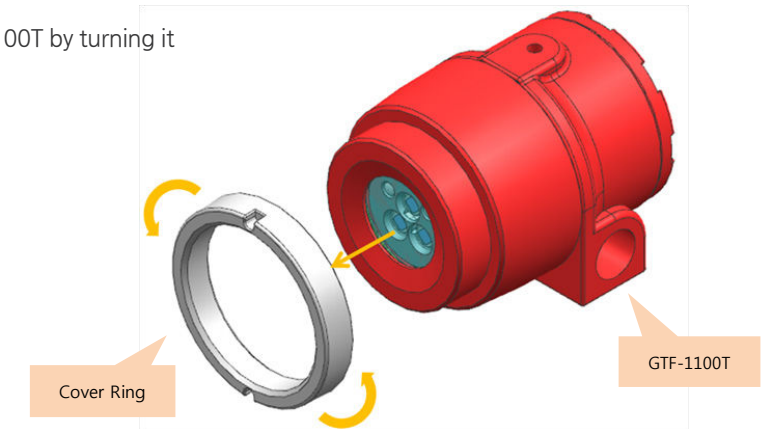

2. Fasten the Cover Ring after coupling of the Weather Proof Cover with GTF-1100T first

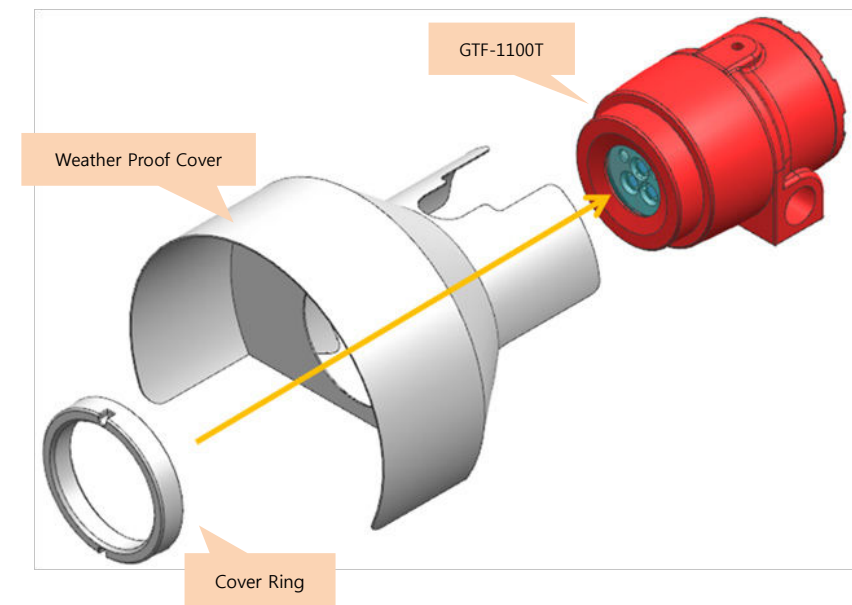

[Figure 16: Weather Proof Cover Assembly]

11.4. Mounting Bracket Dimension (Part No. FMB-1000)

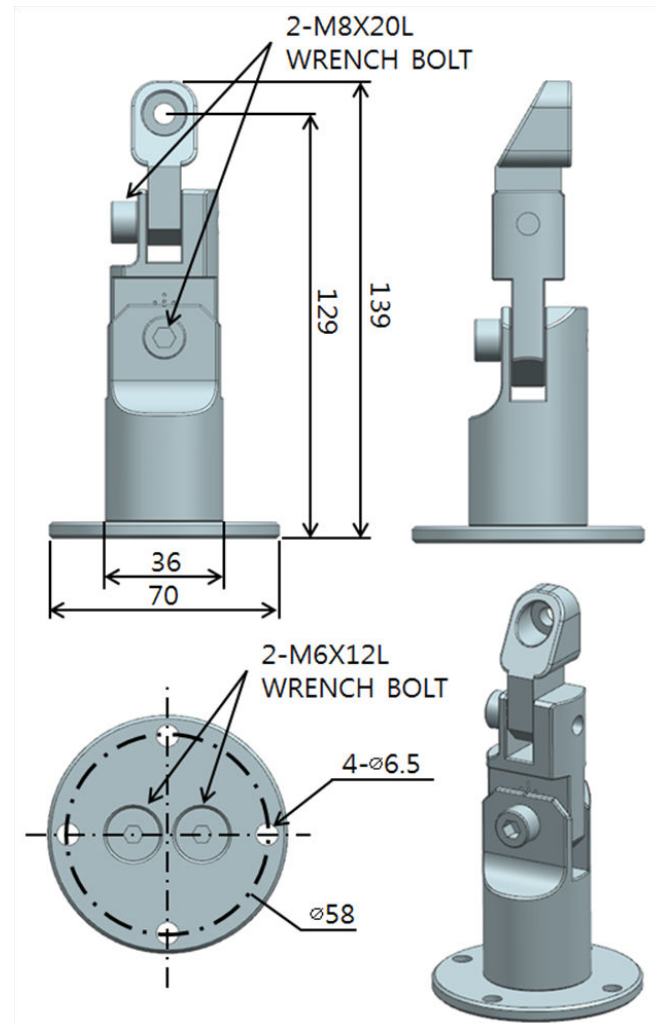

[Figure 17: Bracket Dimension]

11.5. Bracket Assembly

- Assemble to the hole of Bracket and the Mount Tap of GTF-1100T by using M6x10L bolt as shown in the figure.

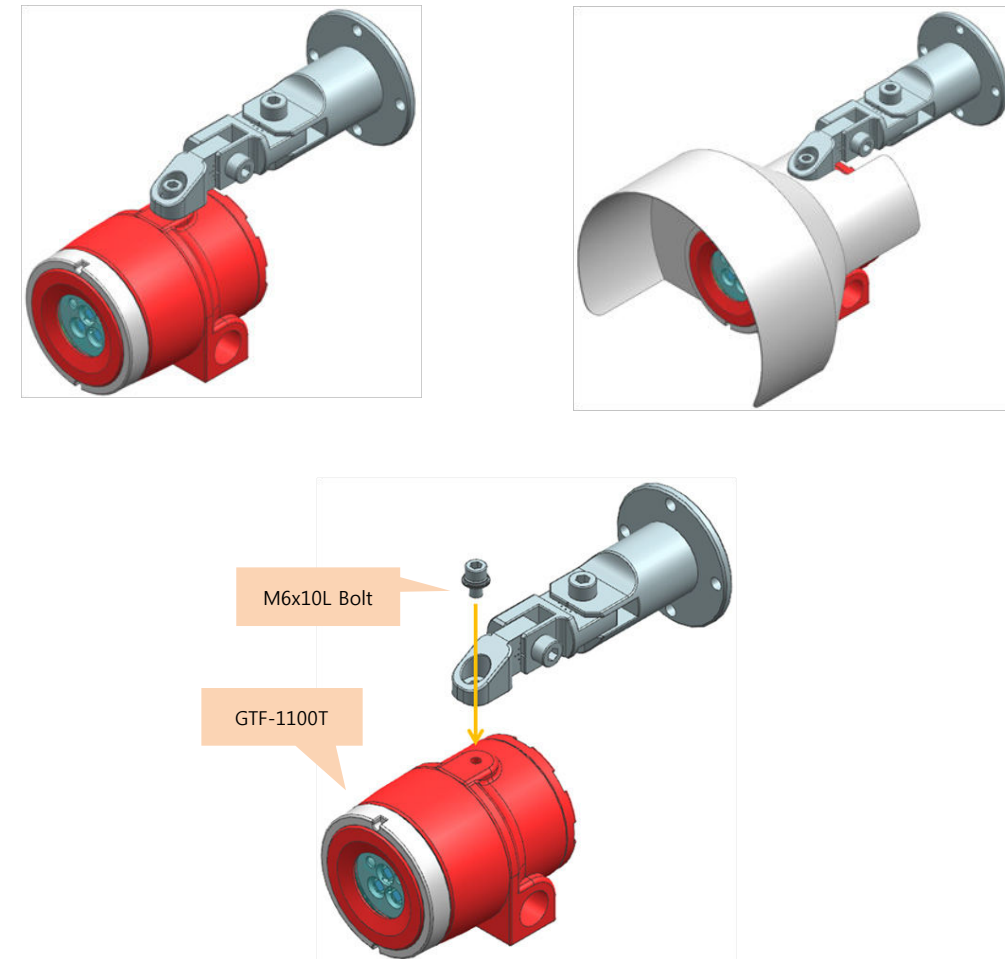

[Figure 18: Bracket Assembly]

11.6. Bracket Tilt

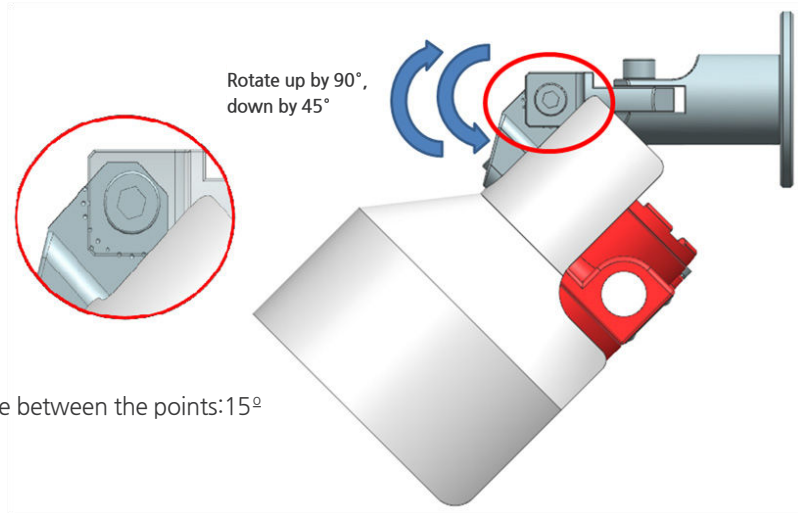
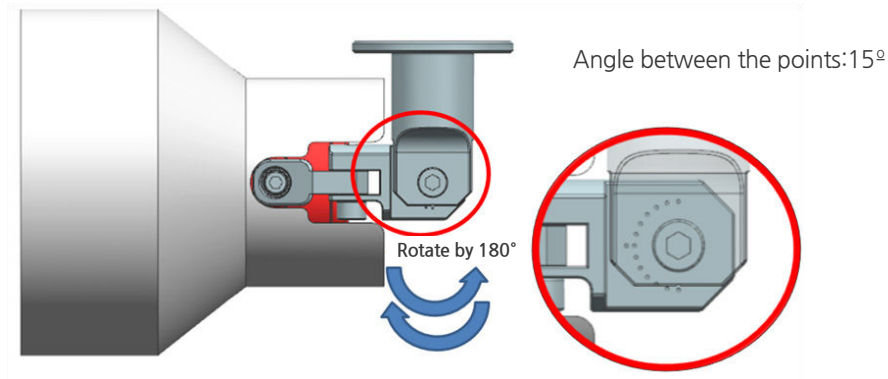

[Figure 19: Bracket Tilt]

11.7. Cable Grand Direction

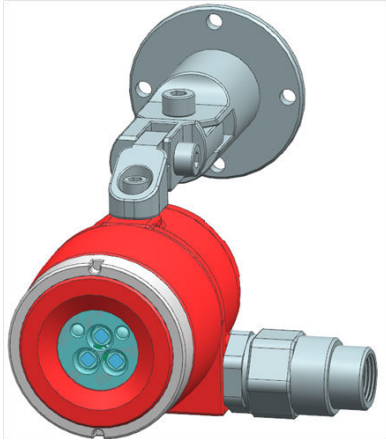
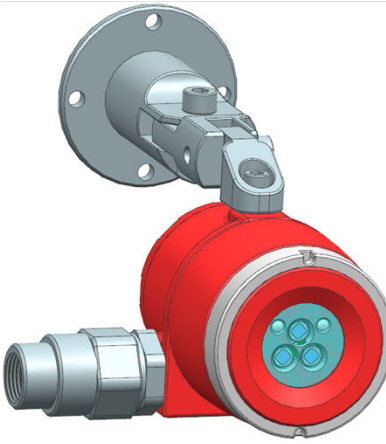
DIRECTION	PICTURE
<p>Right based on the front face of Detector</p>	
<p>Left based on the front face of Detector</p>	

[Table 25: Cable Grand]

Positions with rainwater, etc. that can be an electrical obstacle should be avoided for installation, and installation at a place facilitating operation is recommended since periodic maintenance and repair is required. Since places with vibration or impact can affect output values, avoid those places with vibration or impact for installation, and install in such a way that the sensor unit is directed toward the direction of gravity.

- The present instrument has a pressure-resistant, explosion-proof structure, belonging to the GROUP II aimed at gas, vapor of general business places and chemical plants, and can be used for dangerous places of ZONE 1(ONE)-type and of ZONE 2(TWO)-type 2.
- Allowed temperature belong to lower than 85°C corresponding to T6.
- For ambient temperature, use in the range of T6 = -50 to 60 °C, T5 = -50 to 75 °C, T4 = -50 to 85°C
- Installation altitude: Less than 1,000M above sea level
- Relative humidity: 5% ~ 99%(Non-condensing)
- Installation place: Outdoors and indoors
- Explosion ignition group of target gas or vapor: Ex d IIC T6
- When explosion-proof cable grand is used at cable inlet or wiring construction for metal cable pipe is conducted upon wiring connection operation, electric conduit should be sealed to prevent moving of gas, etc. through electric cable conduit within 50mm or propagation of flames upon explosion.
- More than 5 threads should be made to be coupled upon connection of the present instrument and the electric cable pipe
- Conduct operation under the conditions satisfying other [Standards on selection, installation, and repair, etc. of electric machine, apparatus, wiring, etc. with explosion-proof structure for business places.

VERSION	CONTENTS	DATE
1.0	Manual revised initially	2017.12.19.

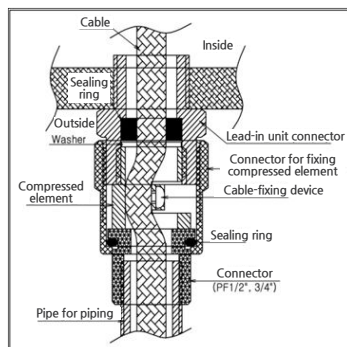

[Figure 20. Pressure-resistant packing type]

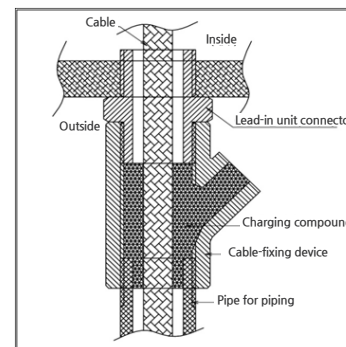

[Figure 21. Y Sealing Compound]