

GASTRON

Headquarters / Engineering research laboratory :
23 Gunpo Advanced Industry 1-ro(Bugok-dong), Gunpo-si, Gyeonggi-do
Tel +82-31-490-0800 Fax +82-31-490-0801

Yeongnam business office / Plant :
55 Gonghangap-gil, 85beon-gil, Gangseogu, Busan Metropolitan City
Tel +51-973-8518 Fax +51-973-8519

E-mail : info@gastron.com

www.gastron.com

GTL-200

Instruction Manual



GASTRON

GASTRON

Read in detail for correct use.

Gas & Flame Detection System

GASTRON



When abnormalities occur after purchasing the product, please contact the following address.

- Address : 23 Gunpo Advanced Industry 1-ro,
Gunpo-si, Gyeonggi-do
- Tel : 031-490-0800
- Fax : 031-490-0801
- URL : www.gastron.com
- e-mail : info@gastron.com

Thank you very much for purchasing a product from Gastron Co. Ltd.

Our Gastron Co.Ltd. is a company specialized in Gas Detector & Gas Monitoring System and have been recognized by many customers for the best quality and use convenience. We always seek to help our customers to find the product they need and we continuously research to develop gas detectors that satisfies our customers. From now on, you can solve all problems related to gas detectors with the products of Gastron. We Gastron will be responsible for your satisfaction.

This user manual describes operation and simple maintenance methods etc. for the gas detector. Please read carefully and store it in a safe place. Using it as a reference will help a lot when you have a question during use.

- Only an individual specialized in explosion-proof devices and warning lights may disassemble the device.
- Please contact our company's technical support, e-mail, or website for inquiries related to inspection and calibration of the explosion-proof warning light.

The product and manual are subject to change without a notice for the product's functional improvement and ease of use.

1. Overview	6	6. Drawings and Dimensions	18
2. Specification	6	6.1. Combination Type	18
2.1. Basic Specifications	6	6.2. Sounder Type	19
2.2. Mechanical Specifications	7	6.3. Beacon Type	20
2.3. Electrical Specifications(DC Type)	7	7. Precautions during Installation	21
2.4. Electrical Specifications (AC Type)	8	Appendix A. Sound Tone Table	22
2.5. Environmental Specifications	8	Appendix B Method to Set Tone	24
3. Name and description of each part	9	8. Revision History	26
3.1. Combination Type Components	10		
3.2. Sounder Type Components	11		
3.3. Beacon Type Components	12		
4. Installation	14		
4.1. Detachment of Cover	14		
4.2. Combination & Sounder Type Terminal Configuration	15		
4.2.1. AC Type Terminal Description	15		
4.2.1. DC Type Terminal Description	15		
4.3. Beacon Type Terminal Configuration	15		
4.3.1. AC Type Terminal Description	15		
4.3.2. DC Type Terminal Description	15		
5. Operation Method	16		
5.1. Operation Status Setting	16		
5.2. External Contact Point Control	16		
5.2.1. Dry Contact Configuration	17		
5.2.2. Wet Contact Configuration	17		

GTL-200 explosion-proof warning light uses semi-permanent LED light source and has aluminum housing. It is an explosion-proof product with excellent durability and safety.

With Gastron's unique lens-type lighting system, it has high emission effect of optical signal. Using built-in switches, sound type, speaker volume, and rotation speed of reflector can be adjusted, thus they can be changed in accordance to installation condition.

LED has 4 colors; Red, Yellow, Green, and Blue and the max. volume of the speaker is 120 dB. 64 different sound tones can be selected and external contact is operated by Dry & Wet Contact Method.

3 types of product are available; combination type with speaker and LED combined together, sounder type with speaker operation only, and beacon type with LED operation only.

GTL-200 explosion-proof warning light has explosion-proof enclosure and is a product that can be used in combination of stand-alone beacon, speaker, and combination types, etc.

2. Specification

2.1. Basic Specifications

ITEMS	SPECIFICATION	
Display Method	LED light source with a rotating reflector	
Display Color Option	Red, Yellow, Green, Blue	
Sound Maximum output	Normal	110dB@1meter(1.2KHz)
	Max	120dB@1meter(1.2KHz)
Tone Selection	64 user selectable tones	
Approvals Classification	Ex d IIC T4~T6 EN 61000-6-2 , EN 61000-6-4	
Ingress Protection	IP66	
Product Type	Sounder	
	Beacon	
	Combination	
Warranty	2Year	

2.2. Mechanical Specifications

ITEMS	SPECIFICATION	
Explosion-Proof Type	Explosion-Proof Enclosure	
Cable Inlet	3/4" PF (1/2" or 3/4" NPT)	
Mounting Holes	Ø 7 ±0.1	
Size (Dimension) (mm)	Sounder	164(W) * 139(H) * 322(177)(D)
	Beacon	164(W) X 278.5(H) X177(D)
	Combination	164(W) * 278.5(H) * 322(177)(D)
Weight	Sounder	App. 5.0kg
	Beacon	App. 5.0kg
	Combination	App. 6.2kg
Body Material	Lamp Cover	Explosion-Proof Tempered Glass
	Body	ALDC12

2.3. Electrical Specifications(DC Type)

ITEMS	SPECIFICATION	
Input Voltage ※ Customer supplied PSU must meet requirements IEC1010-1 and CE Marking requirements.	Absolute min:	18V
	Nominal:	24V
	Absolute max:	30V
	Ripple maximum allowed:	0.1V pk-pk
Sounder Wattage	Max. wattage:	17.8W@+24VDC
	Max. current:	0.74A@+24VDC
Beacon Wattage	Max. wattage:	5.1W@+24VDC
	Max. current:	0.21A@+24VDC
Combination Wattage	Max. wattage:	19.2W@+24VDC
	Max. current:	0.8A@+24VDC
EMC Protection:	CE	

2.4. Electrical Specifications (AC Type)

ITEMS	SPECIFICATION	
Input Voltage ※ Customer supplied PSU must meet requirements IEC1010-1 and CE Marking requirements.	Absolute min:	210V
	Nominal:	220V
	Absolute max:	230V
	Ripple maximum allowed:	0.1V pk-pk
Sounder Wattage	Max. wattage:	19.7W@+220VAC
	Max. current:	0.17A@+220VAC
Beacon Wattage	Max. wattage:	4.7W@+220VAC
	Max. current:	0.05A@+220VAC
Combination Wattage	Max. wattage:	22W@+220VAC
	Max. current:	0.2A@+220VAC
EMC Protection:	CE	

2.5. Environmental Specifications

ITEMS	SPECIFICATION	
Operation Temperature	T5	-40 to 70 °C
	T6	-40 to 60 °C
Storage Temperature	-40 to 70 °C	
Operation Humidity	5 to 99% RH (Non-condensing)	

3.1. Combination Type Components

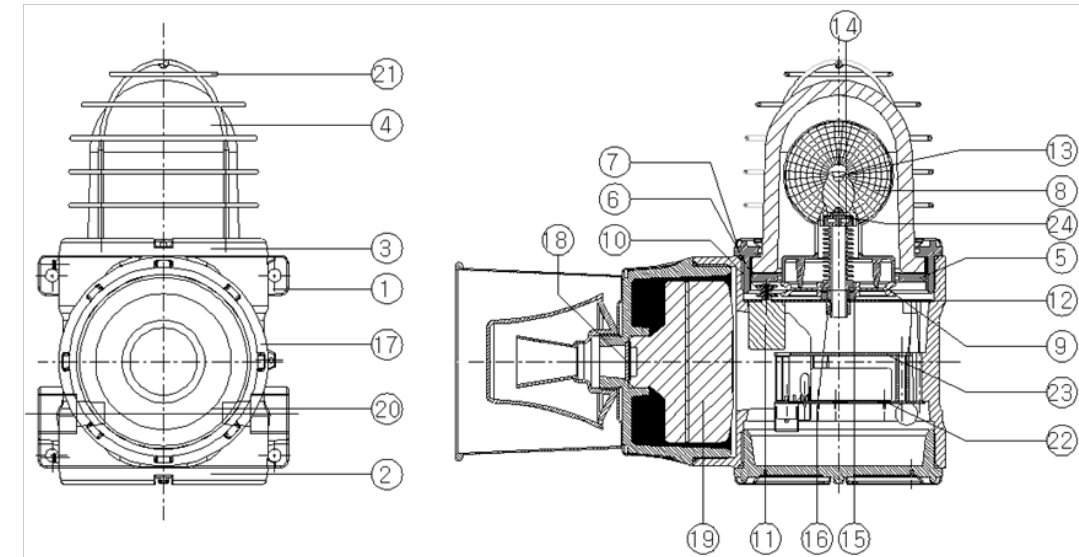

[Figure 1. Combination Type Configuration]

No	ITEMS	SPECIFICATION
1	Case Body	Protects internal PCB and other parts by body.
2	Case cover	Protects internal parts by body.
3	Case Glass Cover	Protects internal glass and other parts by body.
4	Explosion Light Glass	It is an explosion-proof case made of glass material and disperse light to outside.
5	Case Glass Ring	Prevents diversion during explosion light glass fastening.
6	Gasket	Prevents diversion during explosion light glass fastening.
7	O-Ring/1	Inhibits inlet of dust, particles, water, gas
8	Reflector	Diffraacts LED light to emit.
9	Reflector troll plate	Works as rotating plate that rotates reflector.
10	Motor troll plate	Works to deliver rotating speed of motor.
11	Motor	Works to rotate reflector.

3.1. Combination Type Components

No	NAME	DESCRIPTIONS
12	Led assy plate(bracket)	Fastens LED Assy to the body.
13	lens	Lens for light source that emits LED light.
14	Heat sinking plane	Heat-proof body that decreases LED temperature and increases lifetime.
15	Bearing washer	Washer for bearing that operates rotating plate to decrease friction.
16	Heat sinking plane-Net	Net that fastens heat-proof plate to LED assy plate (bracket)
17	Speaker Cover	Protects internal Driver unit and other parts by body
18	Flame Arrester ϕ 25x2	Prevents entrance of debris and delivers buzzer sound to outside.
19	Driver unit	Speaker that emits PCB signal sound.
20	Horn set	Horn that enhances output of driver unit and prevents water from entering.
21	Cage	Protective mesh for explosion light glass
22	Terminal PCB	AC/DC Power Supply
23	Main PCB	Operates by receiving signal upon an error in LED/speaker/motor
24	Led PCB	PCB with LED

[Table 1. Combination Type Configuration Description]

3.2. Sounder Type Configuration

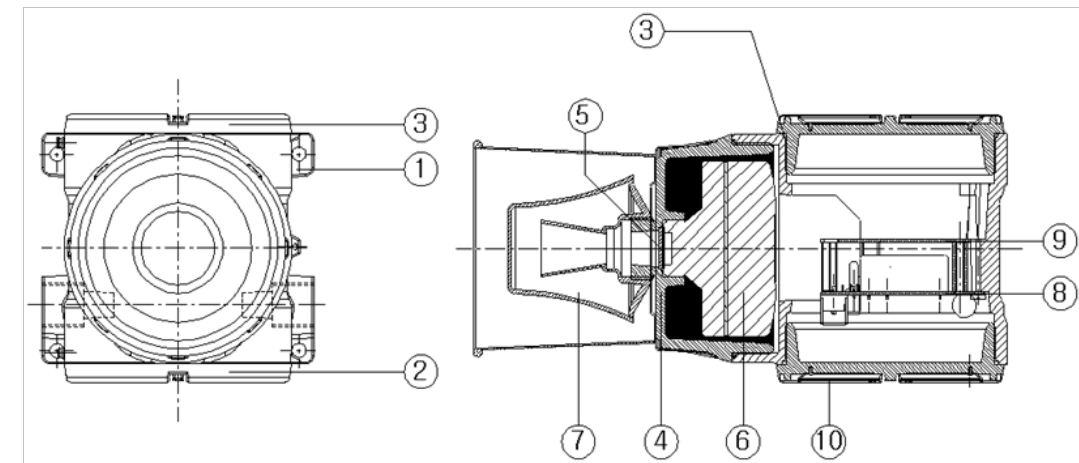

[Figure 2. Sounder Type Configuration]

No	NAME	DESCRIPTIONS
1	Case Body	Protects internal PCB and other parts by body
2	Case cover	Protects internal parts by body
3	O-Ring/1	Inhibits inlet of dust, particles, water, gas
4	Speaker Cover	Protects internal Driver unit and other parts by body
5	Flame Arrester ϕ 25x2	Prevents entrance of debris and delivers buzzer sound to outside.
6	Driver unit	Speaker that emits PCB signal sound.
7	Horn set	Horn that enhances output of driver unit and prevents water from entering.
8	Terminal pcb	AC/DC Power Supply
9	Main pcb	Operates by receiving signal upon an error in LED/speaker/motor
10	Name plate level	Label for Authentication

[Table 2. Sounder Type Configuration Description]

3.3. Beacon Type Components

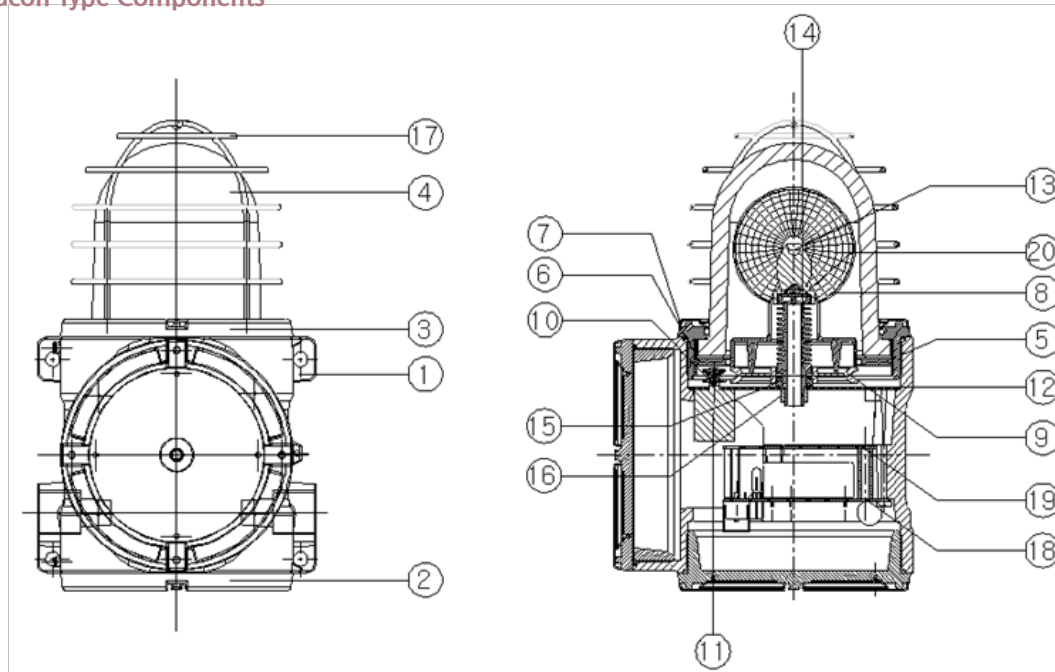

[Table 3. Beacon Type Configuration]

No	NAME	DESCRIPTIONS
1	Case Body	Protects internal PCB and other parts by body
2	Case cover	Protects internal parts by body
3	Case Glass Cover	Protects internal Glass and other parts by body
4	Explosion Light Glass	It is an explosion-proof case made of glass material and disperse light to outside.
5	Case Glass Ring	Prevents diversion during explosion light glass fastening.
6	Gasket	Prevents diversion during explosion light glass fastening.
7	O-Ring/1	Inhibits inlet of dust, particles, water, gas
8	Reflector	Diffraacts LED light to emit.
9	Reflector troll plate	Works as rotating plate that rotates reflector.
10	Motor troll plate	Works to deliver rotating speed of motor.
11	Motor	Works to rotate reflector.
12	Led assy plate(bracket)	Fastens LED Assy to the body.
13	lens	Lens for light source that emits LED light.
14	Heat sinking plane	Heat-proof body that decreases LED temperature and increases lifetime.
15	Bearing washer	Washer for bearing that operates rotating plate to decrease friction.
16	Heat sinking plane-Net	Net that fastens heat-proof plate to LED assy plate (bracket)
17	Cage	Protective mesh for Explosion Light Glass
18	Terminal pcb	AC/DC Power Supply
19	Main pcb	Operates by receiving signal upon an error in LED/Speaker/Motor
20	Led pcb set	PCB with LED

[Table 4. Beacon Type Configuration Description]

- It is prohibited for an individual, other than an approved user or a technician responsible for installation and repair from the head office, to install an explosion-proof warning light on site or open the cover of the installed warning light and manipulate it. This may cause serious loss of life and property from fire, explosion, and etc.
- In addition, please check whether there is any remaining explosive gas or combustible material in the surroundings. Power must be turned off before performing work.

4.1. Detachment of Cover

- Turn the slotted set screw (M4) fixing the cover part of main body 3~4 turns counter clockwise (ccw) using a hex wrench (M2) then turn the cover of gas leak detector ccw to detach the cover.

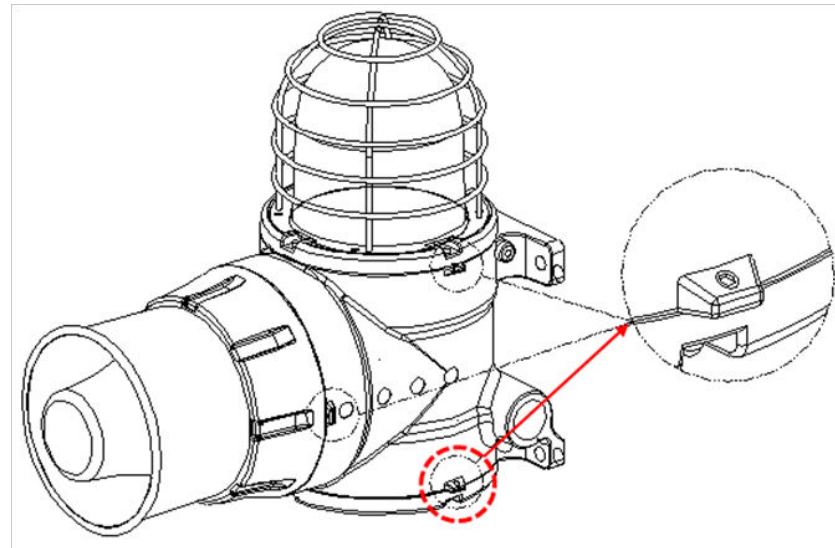

[Figure 3. Slotted Set Screw Configuration]

- When the bottom cover is detached, terminal board for external wiring appears. Perform cable wiring as shown in the terminal configuration below.

4.2. Combination & Sounder Type Terminal Configuration

4.2.1. AC Type Terminal Description

No	PCB SILK	DESCRIPTION	NOTE
1	L1	AC Power (Live)	
2	L2	AC Power (Natural)	
3	S1	External Signal Line 1	Operates upon connecting "COM" terminal to a desired signal line. (Only supports Dry Contact Operation)
4	S2	External Signal Line 2	
5	S3	External Signal Line 3	
6	COM	Digital Ground	

4.2.2. DC Type Terminal Description

No	PCB SILK	DESCRIPTION	NOTE
1	+	DC + Power	
2	-	DC - Power	
3	S1	External Signal Line 1	For Dry Contact Operation, connect to "DC -" power to run. For Wet Contact Operation, run "S1~S3" and "DC-"
4	S2	External Signal Line 2	
5	S3	External Signal Line 3	

4.3. Beacon Type Terminal Configuration

4.3.1. AC Type Terminal Description

No.	PCB SILK	DESCRIPTION
1	L1	AC Power (Live)
2	L1	
3	L2	AC Power (Natural)
4	L2	

4.3.2. DC Type Terminal Description

No.	PCB SILK	DESCRIPTION
1	+	DC + Power
2	+	DC + Power
3	-	DC - Power
4	-	DC - Power

5.1. Operation Status Setting

- By using #1 to #6 internal dip switch, operating tone can be selected. For types of tone, refer to the tone table in Appendix A.
- By using #7 to #8 internal dip switch, operating mode can be changed.

Mode	Dip Switch Setting		Power On	Input External Contact Point (S1, S2, S3)
	#7	#8		
Mode1	OFF	OFF	Beacon operation and set tone output	N/A
Mode2	OFF	ON	No Operation	Beacon operation and set tone operation
Mode3	ON	OFF	Beacon Operation	Set tone Operation

[Table 5. Operation Description]

- For Mode 1, perform basic warning light configuration.
- For Mode 2, it is used when power is inputted regularly and when it is controlled only using external contact points.
- For Mode 3, it is a mode to manually stop tone output and used during setting.

5.2. External Contact Point Control

- In order to select product operation and output tone, internal contact points (S1~S3) of warning light must be controlled.
- By using applicable contact point, it can control operation status and tone output. Refer to the operation status setting table above for control mode.
- For configuration of S1~S3 for tone output, refer to Method for Setting Tone in Appendix B.
- Contact point control configuration can be set in Dry Contact and Wet Contact. Operation configuration depending on Contact Type is set to internal Jumper configuration and related items are as follows.

5.2.1. Dry Contact Configuration

- Using COM terminal, control contact status of S1~S3.

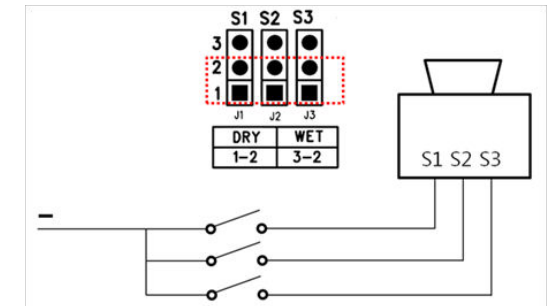

[Figure 4. Dry Contact Configuration]

5.2.2. Wet Contact Configuration

- Using DC+ power, select S1~S3 signal.

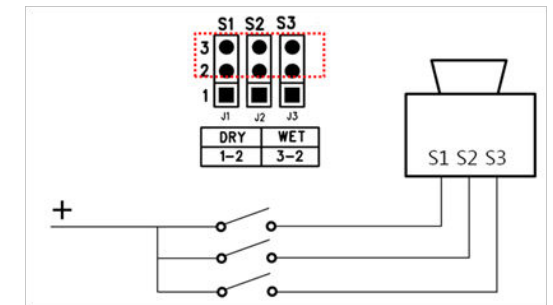

[Figure 5. Wet Contact Configuration]

6.1. Combination Type

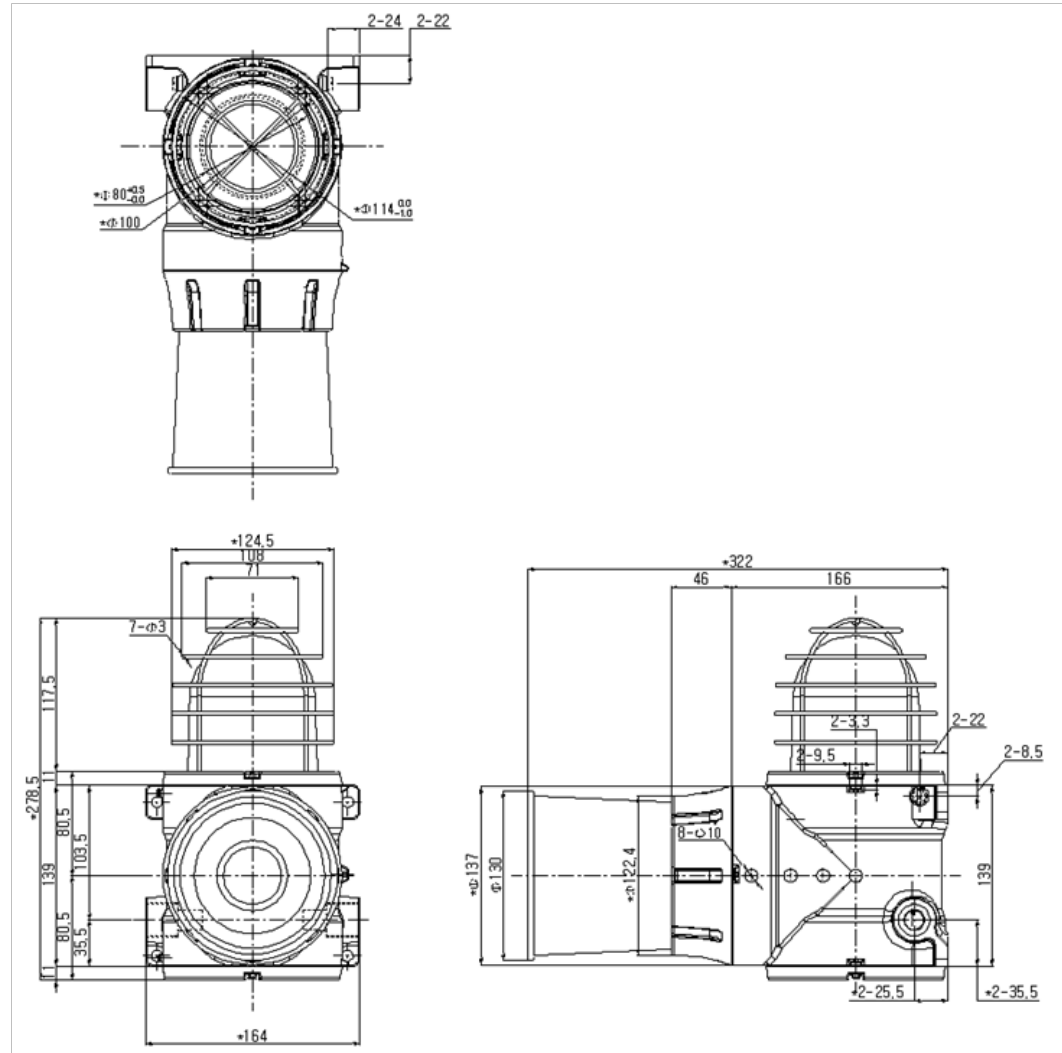

[Figure 6. Combination Type Drawing]

6.2. Sounder Type

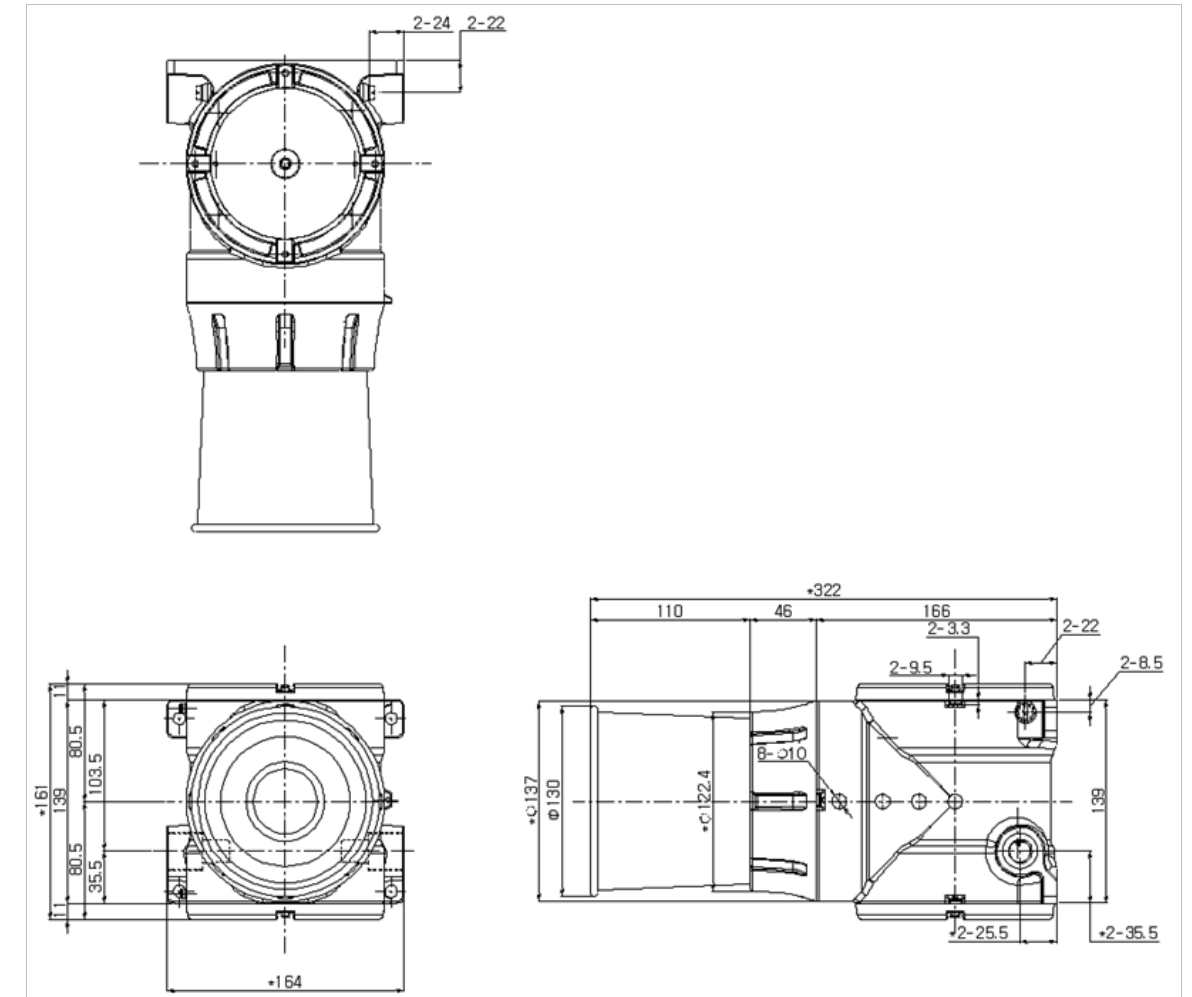

[Figure 7. Sounder Type Drawing]

6.3. Beacon Type

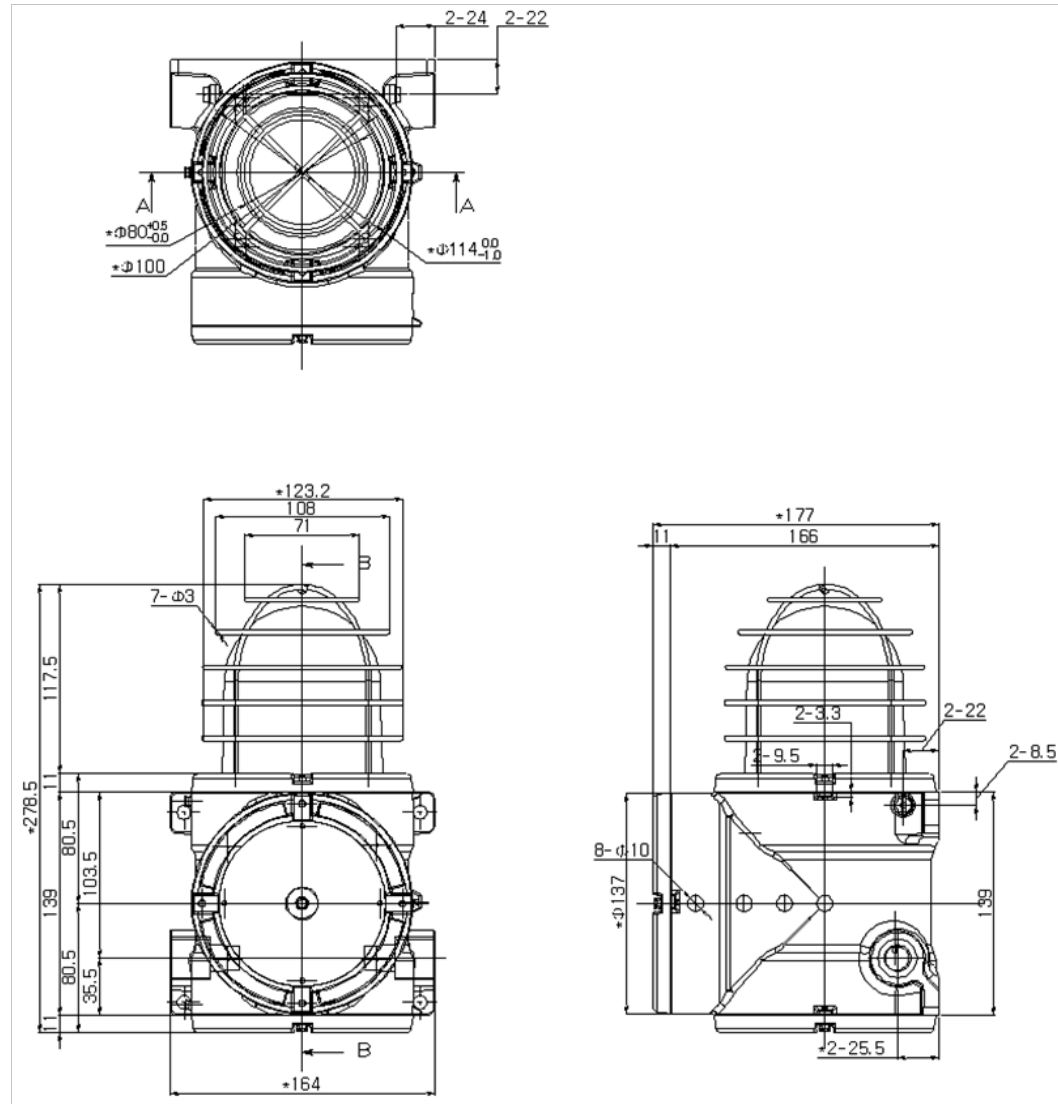

[Figure 8. Beacon Type Drawing]

- Avoid areas with electrical barriers such as rain water, etc. It is recommended to be installed in areas that are easier to work in since regular maintenance is needed. Avoid areas with vibration or shock since they can affect output values.
- This equipment has explosion-proof construction for internal pressure and belongs to GROUP II for gas and vapor in general work sites and chemical plants. It can be used in ZONE 1 (ONE) and ZONE 2 (TWO) hazardous sites.
- Allowable temperature is 85 C or below, which corresponds to T6.
- Surrounding temperature is in a range of -40 °C ~ 70 °C.
- Relative Humidity: 5% ~ 99%
- Installation Site: Indoor and Outdoor
- Explosion Ignition Grade for the Gas or Vapor: Ex d IIC T6
- During wiring work, use explosion-proof cable gland at cable inlet or tightly seal cable conduit during metal cable wiring construction to prevent spread of flames in case of explosion or movement of gas, etc. through the cable conduit within 50 mm.
- When connecting the equipment with cable, screw thread must be tightened 5 threads or more.
- Work in conditions satisfying other [Standards for Selection, Installation, and Maintenance, etc. of Explosion-proof Electric Machine and Equipment Wiring, etc. at Work Site]
- All materials used for cable inlet such as cable gland and sealing fitting, etc. and used as sealing unused inlets must pass the verification!

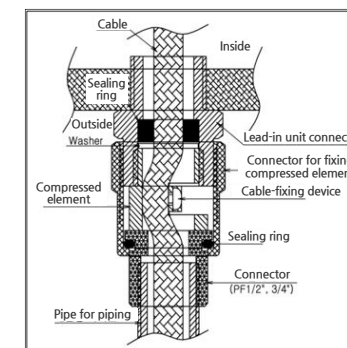

[Figure 9. High-Pressure Packing Type]

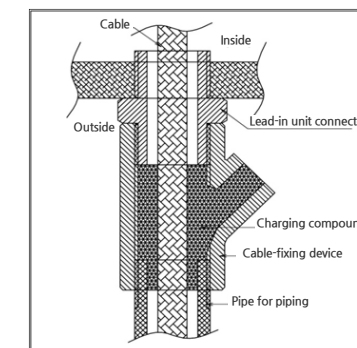

[Figure 10. Y Sealing Compound]

Appendix A, Tone Table

■ Operating tones consist of 64 different types and is according to the table below.

TONE	OUTPUT SIGNAL	FORM OF SIGNAL
Tone1	300Hz Continues	—————
Tone2	340Hz Continues	—————
Tone3	440Hz Continues	—————
Tone4	554Hz Continues	—————
Tone5	660Hz Continues	—————
Tone6	800Hz Continues	—————
Tone7	1000Hz Continues	—————
Tone8	1200Hz Continues	—————
Tone9	2000Hz Continues	—————
Tone10	2400Hz Continues	—————
Tone11	2850Hz Continues	—————
Tone12	420Hz at 625msec on/off	- - - - -
Tone13	544Hz at 875msec on/off	- - - - -
Tone14	660Hz at 150msec on/off	- - - - -
Tone15	660Hz at 1800msec on/off	- - - - -
Tone16	745Hz at 500msec on/off	- - - - -
Tone17	800Hz at 250msec on/off	- - - - -
Tone18	800Hz at 250msec on / 1000msec off	- - - - -
Tone19	1000Hz at 250msec on/off	- - - - -
Tone20	1000Hz at 500msec on/off	- - - - -
Tone21	1000Hz at 250msec on / 1000msec off	- - - - -
Tone22	1000Hz at 1000msec on/off	- - - - -
Tone23	2400Hz at 250msec on/off	- - - - -
Tone24	2400Hz at 500msec on/off	- - - - -
Tone25	2850Hz at 1000msec on/off	- - - - -
Tone26	2850Hz at 150msec on / 100msec off	- - - - -
Tone27	700Hz at 2000msec on/off	- - - - -
Tone28	700Hz at 125msec on/off	- - - - -
Tone29	720Hz at 700msec on/ 300msec off	- - - - -
Tone30	970Hz at 500msec on/off, 1500msec off	- - - - -
Tone31	2850Hz at 500msec on/off, 1500msec off	- - - - -

TONE	OUTPUT SIGNAL	FORM OF SIGNAL
Tone32	Reserved	
Tone33	Reserved	
Tone34	544Hz / 440Hz at 1000msec	
Tone35	800Hz / 1000Hz at 125msec	
Tone36	2400Hz / 2900Hz at 125msec	
Tone37	800Hz / 1000Hz at 250msec	
Tone38	800Hz / 1000Hz at 500msec	
Tone39	1000Hz / 2000Hz at 500msec	
Tone40	2400Hz / 2900Hz at 250msec	
Tone41	500Hz - 1000Hz at 6Hz	
Tone42	500Hz - 1200Hz at 0.3Hz	
Tone43	660Hz - 1200Hz at 1Hz	
Tone44	800Hz - 1000Hz at 1Hz	
Tone45	800Hz - 1000Hz at 7Hz	
Tone46	2400Hz - 2900Hz at 1Hz	
Tone47	2400Hz - 2900Hz at 7Hz	
Tone48	800Hz - 1000Hz at 50Hz	
Tone49	2400Hz - 2900Hz at 50Hz	
Tone50	1200Hz - 500Hz at 1Hz	
Tone51	1400Hz - 1600Hz at 1000msec up / 500msec down	
Tone52	500Hz - 1200Hz at 2500msec up, 500msec off	
Tone53	500Hz - 1200Hz at 5000msec up, 250msec off	
Tone54	800Hz / 660Hz at 1500msec off	
Tone55	800Hz / 1000Hz at 180msec off	
Tone56	250Hz - 1200Hz at 3sec up, 6sec, 3sec down	
Tone57	250Hz - 800Hz at 3sec up, 6sec, 3sec down	
Tone58	250Hz - 2400Hz at 6sec up, 6sec, 6sec down	
Tone59	Simulated Bell	
Tone60	wave-1	
Tone61	wave-2	
Tone62	wave-3	
Tone63	wave-4	
Tone64	wave-5	

Appendix B Method to Set Tone

- To set output tone, when #7 and #8 of dip switches are turned OFF, it is outputted by setting from #1~6 of dip switches after turning power ON, regardless of operation status of external contact points (S1~S3).
- When #8 of dip switch is turned on, the output tone is decided by combination of #1~6 setting of dip switch and external contact point (S1~S3) as shown in the table below.

No.	DIP Switch						DIP S/W #7,8 OFF	DIP S/W #8 ON							
								Stage1	Stage2	Stage 3	Stage 4	Stage 5	Stage 6	Stage 7	Stage 8
	1	2	3	4	5	6	S1	S2	S1+S2	S3	S1+S3	S2+S3	S1+S2+S3		
1							Tone1	Tone1	Tone10	Tone45	Tone22	Tone 60	Tone 61	Tone 5	
2	■						Tone2	Tone2	Tone10	Tone45	Tone22	Tone 60	Tone 61	Tone 5	
3		■					Tone3	Tone3	Tone10	Tone25	Tone39	Tone 60	Tone 61	Tone 5	
4	■	■					Tone4	Tone4	Tone10	Tone45	Tone22	Tone 60	Tone 61	Tone 5	
5			■				Tone5	Tone5	Tone10	Tone39	Tone45	Tone 60	Tone 62	Tone 6	
6	■	■	■				Tone6	Tone6	Tone10	Tone39	Tone45	Tone 60	Tone 62	Tone 5	
7		■	■				Tone7	Tone7	Tone22	Tone9	Tone45	Tone 60	Tone 62	Tone 5	
8	■	■	■				Tone8	Tone8	Tone22	Tone10	Tone45	Tone 60	Tone 62	Tone 5	
9				■			Tone9	Tone9	Tone22	Tone7	Tone39	Tone 60	Tone 63	Tone 5	
10	■						Tone10	Tone10	Tone5	Tone45	Tone22	Tone 60	Tone 63	Tone 6	
11		■					Tone11	Tone11	Tone5	Tone45	Tone22	Tone 60	Tone 63	Tone 6	
12	■	■					Tone12	Tone12	Tone10	Tone39	Tone45	Tone 60	Tone 63	Tone 5	
13			■				Tone13	Tone13	Tone4	Tone9	Tone45	Tone 61	Tone 62	Tone 5	
14	■	■	■				Tone14	Tone14	Tone10	Tone45	Tone22	Tone 61	Tone 62	Tone 5	
15		■	■				Tone15	Tone15	Tone10	Tone22	Tone39	Tone 61	Tone 62	Tone 5	
16	■	■	■				Tone16	Tone16	Tone10	Tone22	Tone39	Tone 61	Tone 62	Tone 5	
17				■			Tone17	Tone17	Tone10	Tone45	Tone35	Tone 62	Tone 63	Tone 5	
18	■	■					Tone18	Tone18	Tone10	Tone22	Tone45	Tone 62	Tone 63	Tone 5	
19		■	■				Tone19	Tone19	Tone10	Tone22	Tone45	Tone 62	Tone 63	Tone 5	
20	■	■	■				Tone20	Tone20	Tone10	Tone22	Tone45	Tone 62	Tone 63	Tone 5	
21			■				Tone21	Tone21	Tone10	Tone45	Tone22	Tone 63	Tone 64	Tone 5	
22	■	■	■				Tone22	Tone22	Tone10	Tone45	Tone39	Tone 63	Tone 64	Tone 5	
23		■	■				Tone23	Tone23	Tone5	Tone45	Tone22	Tone 63	Tone 64	Tone 6	
24	■	■	■				Tone24	Tone24	Tone5	Tone45	Tone38	Tone 63	Tone 64	Tone 6	
25				■			Tone25	Tone25	Tone5	Tone45	Tone38	Tone 64	Tone 60	Tone 6	
26	■						Tone26	Tone26	Tone5	Tone45	Tone38	Tone 64	Tone 60	Tone 6	
27		■					Tone27	Tone27	Tone10	Tone22	Tone45	Tone 64	Tone 60	Tone 5	

No.	DIP Switch						DIP S/W #7,8 OFF	DIP S/W #8 ON							
								Stage1	Stage2	Stage 3	Stage 4	Stage 5	Stage 6	Stage 7	Stage 8
	1	2	3	4	5	6	S1	S2	S1+S2	S3	S1+S3	S2+S3	S1+S2+S3		
28		■					Tone28	Tone28	Tone10	Tone22	Tone45	Tone 64	Tone 60	Tone 5	
29			■				Tone29	Tone29	Tone10	Tone22	Tone45	Tone 61	Tone 63	Tone 5	
30	■						Tone30	Tone30	Tone10	Tone 22	Tone 45	Tone 61	Tone 63	Tone 5	
31		■					Tone31	Tone31	Tone5	Tone 45	Tone 22	Tone 61	Tone 63	Tone 6	
32	■	■					Reserved	Reserved	Reserved	Reserved	Reserved	Reserved	Reserved	Reserved	
33						■	Reserved	Reserved	Reserved	Reserved	Reserved	Reserved	Reserved	Reserved	
34	■						Tone 34	Tone 34	Tone 4	Tone 45	Tone 22	Tone 61	Tone 64	Tone 5	
35		■					Tone 35	Tone 35	Tone 10	Tone 22	Tone 45	Tone 61	Tone 64	Tone 5	
36			■				Tone 36	Tone 36	Tone 10	Tone 22	Tone 45	Tone 61	Tone 64	Tone 5	
37				■			Tone 37	Tone 37	Tone 10	Tone 22	Tone 45	Tone 62	Tone 64	Tone 5	
38					■		Tone 38	Tone 38	Tone 10	Tone 22	Tone 45	Tone 62	Tone 64	Tone 5	
39		■					Tone 39	Tone 39	Tone 22	Tone 7	Tone 45	Tone 62	Tone 64	Tone 5	
40			■				Tone 40	Tone 40	Tone 10	Tone 22	Tone 39	Tone 62	Tone 64	Tone 5	
41				■			Tone 41	Tone 41	Tone 10	Tone 45	Tone 39	Tone 64	Tone 61	Tone 5	
42					■		Tone 42	Tone 42	Tone 10	Tone 45	Tone 39	Tone 64	Tone 61	Tone 5	
43		■					Tone 43	Tone 43	Tone 10	Tone 45	Tone 22	Tone 64	Tone 61	Tone 5	
44			■				Tone 44	Tone 44	Tone 10	Tone 45	Tone 22	Tone 64	Tone 61	Tone 5	
45				■			Tone 45	Tone 45	Tone 10	Tone 22	Tone 39	Tone 64	Tone 63	Tone 5	
46					■		Tone 46	Tone 46	Tone 10	Tone 22	Tone 45	Tone 64	Tone 63	Tone 5	
47		■					Tone 47	Tone 47	Tone 10	Tone 22	Tone 45	Tone 64	Tone 63	Tone 5	
48			■				Tone 48	Tone 48	Tone 10	Tone 39	Tone 45	Tone 64	Tone 63	Tone 5	
49					■		Tone 49	Tone 49	Tone 10	Tone 22	Tone 39	Tone 64	Tone 62	Tone 5	
50						■	Tone 50	Tone 50	Tone 35	Tone 9	Tone 22	Tone 64	Tone 62	Tone 5	
51		■					Tone 51	Tone 51	Tone 10	Tone 45	Tone 22	Tone 64	Tone 62	Tone 5	
52			■				Tone 52	Tone 52	Tone 10	Tone 45	Tone 22	Tone 64	Tone 62	Tone 5	
53				■			Tone 53	Tone 53	Tone 10	Tone 45	Tone 22	Tone 60	Tone 64	Tone 5	
54					■		Tone 54	Tone 54	Tone 6	Tone 22	Tone 39	Tone 60	Tone 64	Tone 5	
55		■					Tone 55	Tone 55	Tone 6	Tone 22	Tone 45	Tone 60	Tone 64	Tone 5	
56			■				Tone 56	Tone 56	Tone 10	Tone 45	Tone 39	Tone 60	Tone 64	Tone 5	
57				■			Tone 57	Tone 57	Tone 10	Tone 45	Tone 22	Tone 62	Tone 60	Tone 5	
58	■						Tone 58	Tone 58	Tone 10	Tone 39	Tone 22	Tone 62	Tone 60	Tone 5	
59		■					Tone 59	Tone 59	Tone 6	Tone 39	Tone 22	Tone 62	Tone 60	Tone 5	
60	■	■					Tone 60	Tone 60	Tone 10	Tone 45	Tone 22	Tone 61	Tone 62	Tone 5	
61			■				Tone 61	Tone 61	Tone 10	Tone 45	Tone 22	Tone 60	Tone 62	Tone 5	
62	■						Tone 62	Tone 62	Tone 10	Tone 45	Tone 22	Tone 60	Tone 61	Tone 5	
63		■					Tone 63	Tone 63	Tone 5	Tone 22	Tone 39	Tone 61	Tone 62	Tone 6	
64	■						Tone 64	Tone 64	Tone 5	Tone 22	Tone 39	Tone 62	Tone 63	Tone 6	

Version	Contents	Date
0.0	* Manual Initial Revision	2013. 03. 14
1.0	* Changed Tone Selection Method and External Contact Point Function	2013. 09. 19
2.0	* Added Tone Table and Contents for Each Product Type	2014. 01. 20
3.0	* Added Case body mount hole size	2014. 04. 04
4.0	* Corrected tone table	2014. 05.04
5.0	* Changed Sound Bracket * Manual Version Modify	2013. 01. 28
5.1	* Added Dip Switch Function Stetting	2016. 06. 16
6.0	* Changed Font	2016. 11. 09
7.0	* Changed Explosion-proof Equipment Cable Entry Installation Regulation 45 cm → 50 mm	2017. 01. 20